

E- CONTENTS

FEE (FUNDAMENTAL OF ELECTRICAL ENGINEERING) 1st Sem ECE

**By
BUNTY
LECT. ECE
GP JHAJJAR**

ELECTRICITY

Introduction

- If the electric charge flows through a conductor, such as a metallic wire, it is known as the **electric current** in the conductor.
- A continuous and closed path of an electric current is known as an **electric circuit**.

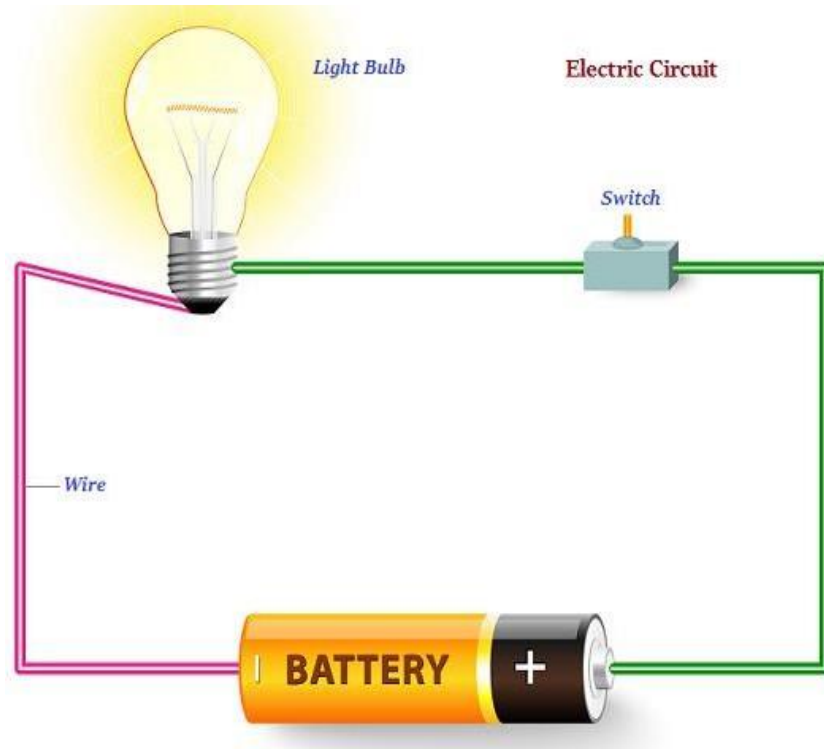







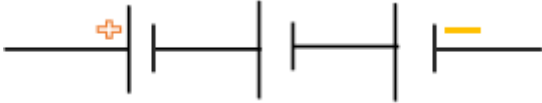

- In an electric circuit, usually, the direction of electric current is considered as opposite to the direction of the flow of electrons, which are considered as negative charges.
- The SI unit of electric charge is **coulomb (C)**.
- Coulomb is equivalent to the charge contained in closely 6×10^{18} electrons.
- The electric current is expressed by a unit known as an **ampere (A)**.
- One ampere constitutes by the flow of one coulomb of charge per second, i.e., $1 \text{ A} = 1 \text{ C}/1 \text{ s}$.
- The instrument that measures electric current in a circuit is known as **ammeter**.
- The electric current flows in the circuit starting from the positive terminal to the negative terminal of the cell through the bulb and ammeter.

Electric Potential and Potential Difference

- The electrons of a conductor move only if there is a difference of electric pressure, known as the **potential difference**.
- The chemical action within a cell produces the potential difference across the terminals of the cell. Further, when this cell is linked to a conducting circuit element, the potential difference sets the charges in motion and generates an electric current.
- The SI unit of electric potential difference is given **volt (V)**.
- The instrument that measures the potential difference is known as the **voltmeter**.

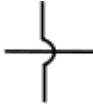
Circuit Diagram

- Some defined symbols are used to illustrate the most commonly used electrical components in circuit diagrams.
- The following table describes some of the symbols commonly used to define the electric components –

Components	Symbols
An electric cell	
A battery or combination of cells	
Plug key or switch Open	
Plug key or switch closed	
A wire joint	
Wires crossing without joining	
Electric bulb	
A resistor of resistance R	
Variable resistance or rheostat	

Ammeter	
Voltmeter	

Ohm's Law

- A German physicist, **Georg Simon Ohm** in 1827, stated that **“The electric current flowing through a metallic wire is directly proportional to the potential difference V , across its ends provided its temperature remains the same.”**

Electric Power

- The rate at which electric energy is dissipated or consumed in an electric circuit is known as **electric power**.
- The SI unit of electric power is **watt (W)**.

What is Electricity?

Electricity is all around us--powering technology like our cell phones, computers, lights, soldering irons, and air conditioners. It's tough to escape it in our modern world. Even when you try to escape electricity, it's still at work throughout nature, from the lightning in a thunderstorm to the synapses inside our body. But what exactly *is* electricity? This is a very complicated question, and as you dig deeper and ask more questions, there really is not a definitive answer, only abstract representations of how electricity interacts with our surroundings.



Electricity is a natural phenomenon that occurs throughout nature and takes many different forms. In this tutorial we'll focus on current electricity: the stuff that powers our electronic gadgets. Our goal is to understand how electricity flows from a power source through wires, lighting up LEDs, spinning motors, and powering our communication devices.

Electricity is briefly defined as the **flow of electric charge**, but there's so much behind that simple statement. Where do the charges come from? How do we move them? Where do they move to? How does an electric charge cause mechanical motion or make things light up? So many questions! To begin to explain what electricity is we need to zoom way in, beyond the matter and molecules, to the atoms that make up everything we interact with in life.

Through Atoms

To understand the fundamentals of electricity, we need to begin by focusing in on atoms, one of the basic building blocks of life and matter. Atoms exist in over a hundred different forms as chemical elements like hydrogen, carbon, oxygen, and copper. Atoms of many types can combine to make molecules.

Building Blocks of Atoms

An atom is built with a combination of three distinct particles: **electrons, protons, and neutrons**. Each atom has a center nucleus, where the protons and neutrons are densely packed together. Surrounding the nucleus are a group of orbiting electrons.

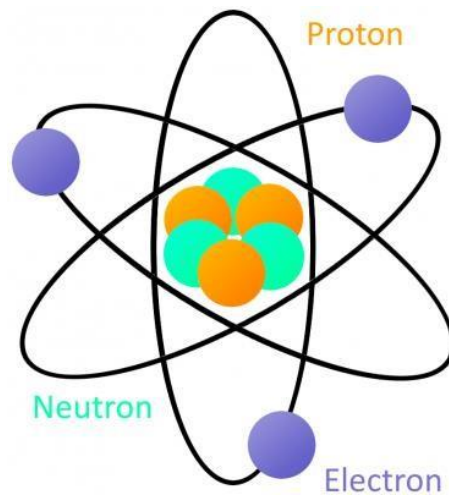

A very simple atom model

Every atom must have at least one proton in it. The number of protons in an atom is important, because it defines what chemical element the atom represents. For example, an atom with just one proton is **hydrogen** and an atom with 29 protons is **copper**. This count of protons is called the atom's **atomic number**.

Electrons are critical to the workings of electricity. In its most stable, balanced state, an atom will have the same number of electrons as protons. As in the **Bohr atom model** below, a nucleus with 29 protons (a copper atom) is surrounded by an equal number of electrons.

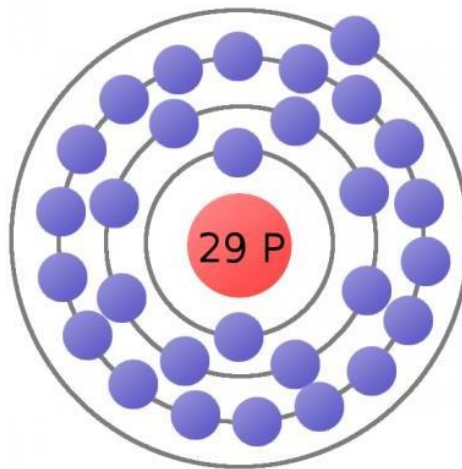

The atom's electrons aren't all forever bound to the atom. The electrons on the outer orbit of the atom are called **valence electrons**. With enough outside force, a valence electron can escape orbit of the atom and become free. **Free electrons** allow us to move charge, which is what electricity is all about.

Flowing Charges

Electricity is defined as the flow of electric charge. **Charge** is a property of matter- just like mass, volume, or density. It is measurable. The key concept with charge is that it can come in two types: **positive (+) or negative (-)**.

In order to move charge we need **charge carriers**, and that's where our knowledge of atomic particles--specifically electrons and protons--comes in handy. Electrons always carry a negative

charge, while protons are always positively charged. Neutrons are neutral, they have no charge. Both electrons and protons carry the same **amount** of charge.

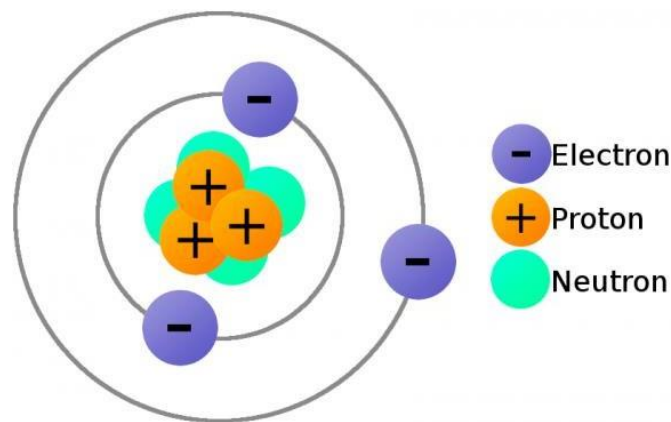

A lithium atom (3 protons) model with the charges labeled.

Electrostatic Force

Electrostatic force (also called **Coulomb's law**) is a force that operates between charges. It states that charges of the same type repel each other, while charges of opposite types are attracted together. **Opposites attract, and likes repel.**

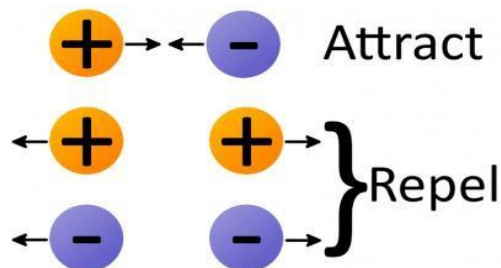

The **amount** of force acting on two charges depends on how far they are from each other. The closer two charges get, the greater the force (either pushing together, or pulling away) becomes.

Making Charges Flow

We now have all the tools to make charges flow. **Electrons** in atoms can act as our **charge carrier**, because every electron carries a negative charge. If we can free an electron from an atom and force it to move, we can create electricity.

Consider the atomic model of a copper atom, one of the preferred elemental sources for charge flow. In its balanced state, copper has 29 protons in its nucleus and an equal number of electrons orbiting around it. Electrons orbit at varying distances from the nucleus of the atom. Electrons closer to the nucleus feel a much stronger attraction to the center than those in distant orbits. The outermost electrons of an atom are called the **valence electrons**, these require the least amount of force to be freed from an atom.

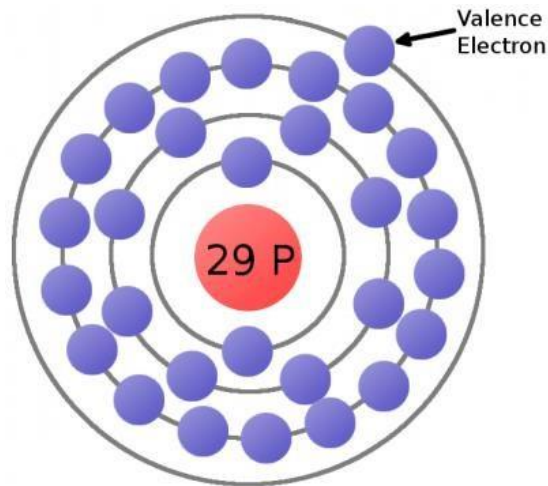

This is a copper atom diagram: 29 protons in the nucleus, surrounded by bands of circling electrons. Electrons closer to the nucleus are hard to remove while the valence (outer ring) electron requires relatively little energy to be ejected from the atom.

Using enough electrostatic force on the valence electron--either pushing it with another negative charge or attracting it with a positive charge--we can eject the electron from orbit around the atom creating a free electron.

Now consider a copper wire: matter filled with countless copper atoms. As our **free electron** is floating in a space between atoms, it's pulled and prodded by surrounding charges in that space. In this chaos the free electron eventually finds a new atom to latch on to; in doing so, the negative charge of that electron ejects another valence electron from the atom. Now a new electron is drifting through free space looking to do the same thing. This chain effect can continue on and on to create a flow of electrons called **electric current**.

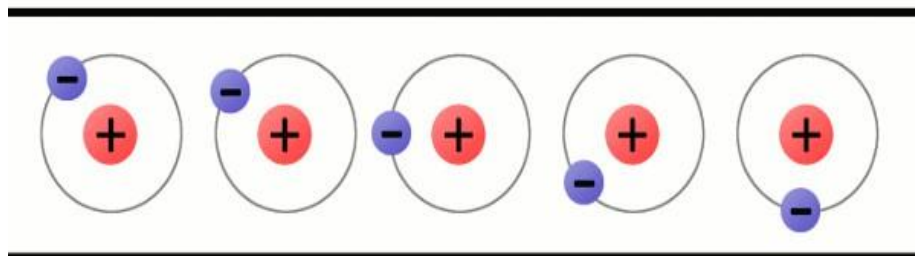

A very simplified model of charges flowing through atoms to make current.

Conductivity

Some elemental types of atoms are better than others at releasing their electrons. To get the best possible electron flow we want to use atoms which don't hold very tightly to their valence electrons. An element's conductivity measures how tightly bound an electron is to an atom.

Elements with high conductivity, which have very mobile electrons, are called **conductors**. These are the types of materials we want to use to make wires and other components which aid in electron flow. Metals like copper, silver, and gold are usually our top choices for good conductors.

Elements with low conductivity are called **insulators**. Insulators serve a very important purpose: they prevent the flow of electrons. Popular insulators include glass, rubber, plastic, and air.

Current Electricity

Current electricity is the form of electricity which makes all of our electronic gizmos possible. This form of electricity exists when charges are able to **constantly flow**. As opposed to static electricity where charges gather and remain at rest, current electricity is dynamic; charges are always on the move

Circuits

In order to flow, current electricity requires a **circuit**: a closed, never-ending loop of conductive material. A circuit could be as simple as a conductive wire connected end-to-end, but useful circuits usually contain a mix of wire and other components which control the flow of electricity.

Electric Fields

We have a handle on how electrons flow through matter to create electricity. That's all there is to electricity. Well, almost all. Now we need a source to induce the flow of electrons. Most often that source of electron flow will come from an electric field.

What's a Field?

A field is a tool we use to model physical interactions which **don't involve any observable contact**. Fields can't be seen as they don't have a physical appearance, but the effect they have is very real.

We're all subconsciously familiar with one field in particular: **Earth's gravitational field**, the effect of a massive body attracting other bodies. Earth's gravitational field can be modeled with a set of vectors all pointing into the center of the planet; regardless of where you are on the surface, you'll feel the force pushing you towards it.

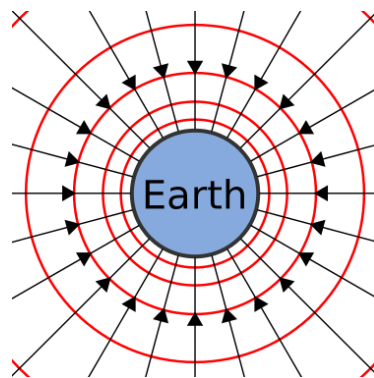

The strength or intensity of fields isn't uniform at all points in the field. The further you are from the source of the field the less effect the field has. The magnitude of Earth's gravitational field decreases as you get further away from the center of the planet.

As we go on to explore electric fields in particular remember how Earth's gravitational field works, both fields share many similarities. Gravitational fields exert a force on objects of mass, and electric fields exert a force on objects of charge.

Electric Fields

Electric fields (e-fields) are an important tool in understanding how electricity begins and continues to flow. Electric fields **describe the pulling or pushing force in a space between charges**. Compared to Earth's gravitational field, electric fields have one major difference: while Earth's field generally only attracts other objects of mass (since everything is so significantly less massive), electric fields push charges away just as often as they attract them.

The direction of electric fields is always defined as the **direction a positive test charge would move** if it was dropped in the field. The test charge has to be infinitely small, to keep its charge from influencing the field.

We can begin by constructing electric fields for solitary positive and negative charges. If you dropped a positive test charge near a negative charge, the test charge would be attracted towards the **negative** charge. So, for a single, negative charge we draw our electric field arrows **pointing inward** at all directions. That same test charge dropped near another **positive** charge would result in an outward repulsion, which means we draw **arrows going out** of the positive charge.

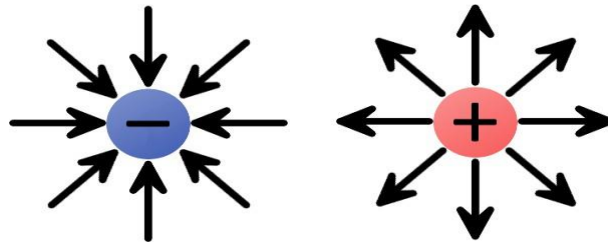

The electric fields of single charges. A negative charge has an inward electric field because it attracts positive charges. The positive charge has an outward electric field, pushing away like charges. Groups of electric charges can be combined to make more complete electric fields.

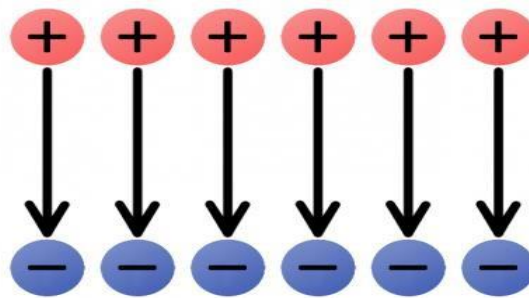

The uniform e-field above points away from the positive charges, towards the negatives. Imagine a tiny positive test charge dropped in the e-field; it should follow the direction of the arrows. As we've seen, electricity usually involves the flow of electrons--negative charges--which flow **against** electric fields.

Electric fields provide us with the pushing force we need to induce current flow. An electric field in a circuit is like an electron pump: a large source of negative charges that can propel electrons, which will flow through the circuit towards the positive lump of charges.

Electric Potential (Energy)

When we harness electricity to power our circuits, gizmos, and gadgets, we're really transforming energy. Electronic circuits must be able to store energy and transfer it to other forms like heat, light, or motion. The stored energy of a circuit is called electric potential energy.

Energy? Potential Energy?

To understand potential energy we need to understand energy in general. Energy is defined as the ability of an object to do *work* on another object, which means moving that object some distance. Energy comes in **many forms**, some we can see (like mechanical) and others we can't (like chemical or electrical). Regardless of what form it's in, energy exists in one of two **states**: kinetic or potential.

An object has **kinetic energy** when it's in motion. The amount of kinetic energy an object has depends on its mass and speed. **Potential energy**, on the other hand, is a **stored energy** when an object is at rest. It describes how much work the object could do if set into motion. It's an energy we can generally control. When an object is set into motion, its potential energy transforms into kinetic energy.

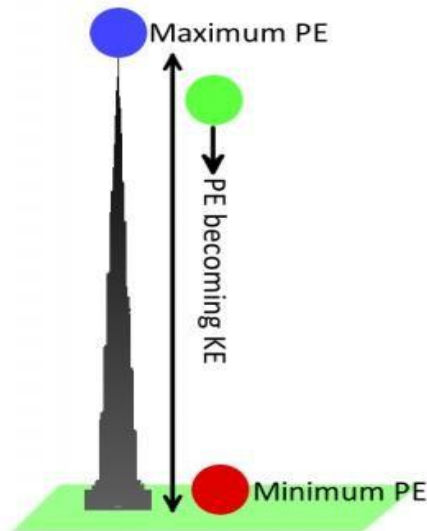

Let's go back to using gravity as an example. A bowling ball sitting motionless at the top of **Khalifa tower** has a lot of potential (stored) energy. Once dropped, the ball--pulled by the gravitational field--accelerates towards the ground. As the ball accelerates, potential energy is converted into kinetic energy (the energy from motion). Eventually all of the ball's energy is converted from potential to kinetic, and then passed on to whatever it hits. When the ball is on the ground, it has a very low potential energy.

Electric Potential Energy

Just like mass in a gravitational field has gravitational potential energy, charges in an electric field have an **electric potential energy**. A charge's electric potential energy describes how much stored energy it has, when set into motion by an electrostatic force, that energy can become kinetic, and the charge can do work.

Like a bowling ball sitting at the top of a tower, a positive charge in close proximity to another positive charge has a high potential energy; left free to move, the charge would be repelled away from the like charge. A positive test charge placed near a negative charge would have low potential energy, analogous to the bowling ball on the ground.

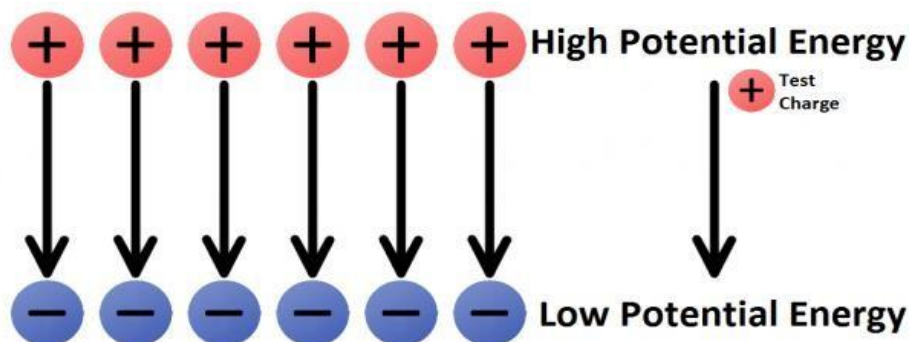

To instill anything with potential energy, we have to do **work** by moving it over a distance. In the case of the bowling ball, the work comes from carrying it up 163 floors, against the field of gravity. Similarly, work must be done to push a positive charge against the arrows of an electric field (either towards another positive charge, or away from a negative charge). The further up the field the charge goes, the more work you have to do. Likewise, if you try to pull a negative charge *away* from a positive charge--against an electric field--you have to do work.

For any charge located in an electric field its electric potential energy depends on the type (positive or negative), amount of charge, and its position in the field. Electric potential energy is measured in units of joules (J).

Electric Potential

Electric potential builds upon electric potential *energy* to help define how much **energy is stored in electric fields**. It's another concept which helps us model the behavior of electric fields. Electric potential is *not* the same thing as electric potential energy!

At any point in an electric field the electric potential is the **amount of electric potential energy divided by the amount of charge** at that point. It takes the charge quantity out of the equation and leaves us with an idea of how much potential energy specific areas of the electric field may provide. Electric potential comes in units of joules per coulomb (J/C), which we define as a **volt** (V).

In any electric field there are two points of electric potential that are of significant interest to us. There's a point of high potential, where a positive charge would have the highest possible potential energy, and there's a point of low potential, where a charge would have the lowest possible potential energy.

One of the most common terms we discuss in evaluating electricity is **voltage**. A voltage is the difference in potential between two points in an electric field. Voltage gives us an idea of just how much pushing force an electric field has.

With potential and potential energy under our belt we have all of the ingredients necessary to make current electricity. Let's do it!

Electricity in Action!

After studying particle physics, field theory, and potential energy, we now know enough to make electricity flow. Let's make a circuit!

First we will review the ingredients we need to make electricity:

- The definition of electricity is the **flow of charge**. Usually our charges will be carried by free-flowing electrons.
- Negatively-charged **electrons** are loosely held to atoms of conductive materials. With a little push we can free electrons from atoms and get them to flow in a generally uniform direction.
- A closed **circuit** of conductive material provides a path for electrons to continuously flow.
- The charges are propelled by an **electric field**. We need a source of electric potential (voltage), which pushes electrons from a point of low potential energy to higher potential energy.

A Short Circuit

Batteries are common energy sources which convert chemical energy to electrical energy. They have two terminals, which connect to the rest of the circuit. On one terminal there are an excess of negative charges, while all of the positive charges coalesce on the other. This is an electric potential difference just waiting to act!



If we connected our wire full of conductive copper atoms to the battery, that electric field will influence the negatively-charged free electrons in the copper atoms. Simultaneously pushed by the negative terminal and pulled by the positive terminal, the electrons in the copper will move from atom to atom creating the flow of charge we know as electricity.

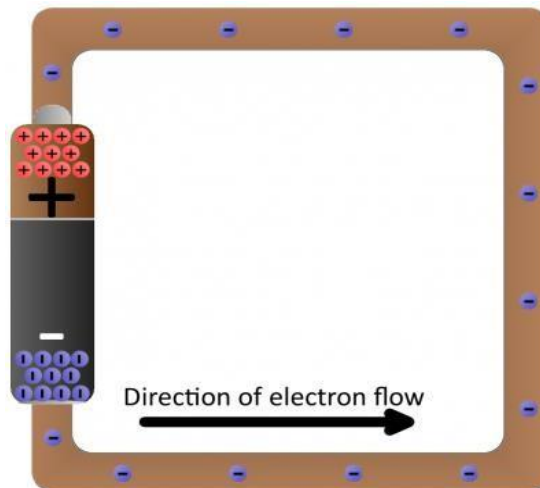

After a second of the current flow, the electrons have actually moved *very* little--fractions of a centimeter. However, the energy produced by the current flow is *huge*, especially since there's nothing in this circuit to slow down the flow or consume the energy. Connecting a pure conductor directly across an energy source is a **bad idea**. Energy moves very quickly through the system and is transformed into heat in the wire, which may quickly turn into melting wire or fire.

Illuminating a Light Bulb

Instead of wasting all that energy, not to mention destroying the battery and wire, let's build a circuit that does something useful! Generally an electric circuit will transfer electric energy into some other form--light, heat, motion, etc. If we connect a light bulb to the battery with wires in between, we have a simple, functional circuit.

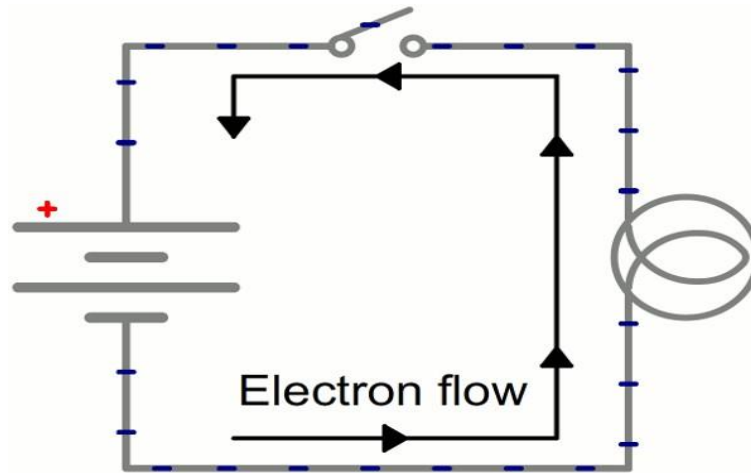

Schematic: A battery (left) connecting to a light bulb (right), the circuit is completed when the switch (top) closes. With the circuit closed, electrons can flow, pushed from the negative terminal of the battery through the light bulb, to the positive terminal.

While the electrons move at a snails pace, the electric field affects the entire circuit almost instantly (we're talking speed of light fast). Electrons throughout the circuit, whether at the lowest potential, highest potential, or right next to the light bulb, are influenced by the electric field. When the switch closes and the electrons are subjected to the electric field, all electrons in the circuit start flowing at seemingly the same time. Those charges nearest the light bulb will take one step through the circuit and start transforming energy from electrical to light (or heat).

Ohms Law and Power

The relationship between Voltage, Current and Resistance in any DC electrical circuit was firstly discovered by the German physicist Georg Ohm.

Georg Ohm found that, at a constant temperature, the electrical current flowing through a fixed linear resistance is directly proportional to the voltage applied across it, and also inversely proportional to the resistance. This relationship between the Voltage, Current and Resistance forms the basis of **Ohms Law** and is shown below.

Ohms Law Relationship

$$\text{Current, (I)} = \frac{\text{Voltage, (V)}}{\text{Resistance, (R)}} \text{ in Amperes, (A)}$$

By knowing any two values of the Voltage, Current or Resistance quantities we can use **Ohms Law** to find the third missing value. **Ohms Law** is used extensively in electronics formulas and calculations so it is "very important to understand and accurately remember these formulas".

To find the Voltage, (V)

$$[V = I \times R] \quad V \text{ (volts)} = I \text{ (amps)} \times R \text{ (}\Omega\text{)}$$

To find the Current, (I)

$$[I = V \div R] \quad I \text{ (amps)} = V \text{ (volts)} \div R \text{ (}\Omega\text{)}$$

To find the Resistance, (R)

$$[R = V \div I] \quad R \text{ (}\Omega\text{)} = V \text{ (volts)} \div I \text{ (amps)}$$

It is sometimes easier to remember this Ohms law relationship by using pictures. Here the three quantities of V, I and R have been superimposed into a triangle (affectionately called the **Ohms Law Triangle**) giving voltage at the top with current and resistance below. This arrangement represents the actual position of each quantity within the Ohms law formulas.

Ohms Law Triangle

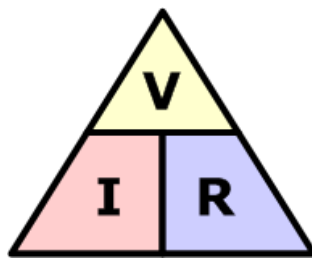

Transposing the standard Ohms Law equation above will give us the following combinations of the same equation:

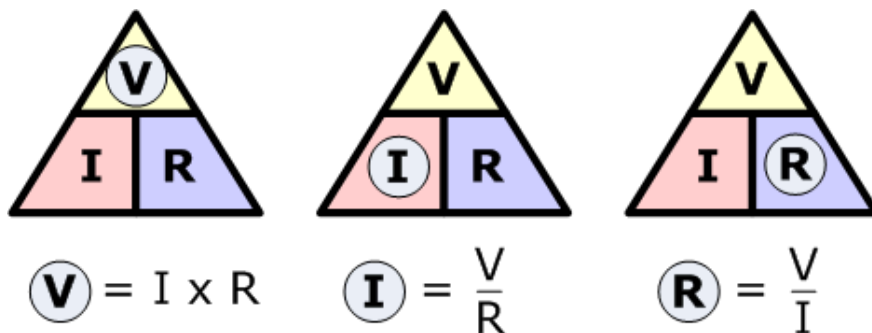

Then by using Ohms Law we can see that a voltage of 1V applied to a resistor of 1 Ω will cause a current of 1A to flow and the greater the resistance value, the less current that will flow for a given applied voltage. Any Electrical device or component that obeys “Ohms Law” that is, the current flowing through it is proportional to the voltage across it ($I \propto V$), such as resistors or cables, are said to be “**Ohmic**” in nature, and devices that do not, such as transistors or diodes, are said to be “**Non-ohmic**” devices.

Ohm's Law

□ Definition:

Ohm's Law states that the **current (I)** flowing through a conductor is **directly proportional** to the **voltage (V)** across it, provided the **temperature and other physical conditions remain**

constant.

Formula:

$$V = I \cdot R$$

Where:

- V = Voltage (Volts)
- I = Current (Amperes)
- R = Resistance (Ohms, Ω)

Rearranged Forms:

- $I = \frac{V}{R}$
- $R = \frac{V}{I}$

Example:

A current of **0.5A** flows through a resistor of **20 Ω** . Find the voltage.

$$V = I \cdot R = 0.5 \cdot 20 = 10V$$

$$V = I * R = 0.5 * 20 = 10V$$

Voltage is **10 volts**.

Electrical Power in Circuits

Electrical Power, (P) in a circuit is the rate at which energy is absorbed or produced within a circuit. A source of energy such as a voltage will produce or deliver power while the connected load absorbs it. Light bulbs and heaters for example, absorb electrical power and convert it into either heat, or light, or both. The higher their value or rating in watts the more electrical power they are likely to consume.

The quantity symbol for power is P and is the product of voltage multiplied by the current with the unit of measurement being the **Watt** (W). Prefixes are used to denote the various multiples or sub-multiples of a watt, such as: **milliwatts** (mW = 10⁻³W) or **kilowatts** (kW = 10³W).

Then by using Ohm's law and substituting for the values of V, I and R the formula for electrical power can be found as:

To find the Power (P)

$$[P = V \times I] \quad P \text{ (watts)} = V \text{ (volts)} \times I \text{ (amps)}$$

Also:

$$[P = V^2 \div R] \quad P \text{ (watts)} = V^2 \text{ (volts)} \div R \text{ (}\Omega\text{)}$$

Also:

$$[P = I^2 \times R] \quad P \text{ (watts)} = I^2 \text{ (amps)} \times R \text{ (}\Omega\text{)}$$

Again, the three quantities have been superimposed into a triangle this time called a **Power Triangle** with power at the top and current and voltage at the bottom. Again, this arrangement represents the actual position of each quantity within the Ohms law power formulas.

The Power Triangle

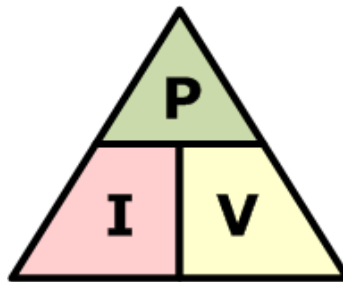

and again, transposing the basic Ohms Law equation above for power gives us the following combinations of the same equation to find the various individual quantities:

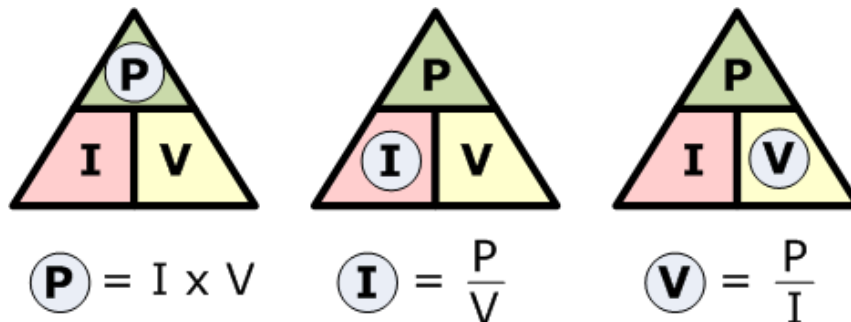

So we can see that there are three possible formulas for calculating electrical power in a circuit. If the calculated power is positive, (+P) in value for any formula the component absorbs the power, that is it is consuming or using power. But if the calculated power is negative, (-P) in value the component produces or generates power, in other words it is a source of electrical power such as batteries and generators.

Kirchhoff's Current Law (KCL)

Definition:

Kirchhoff's Current Law (KCL) states that:

- The total current entering a junction (node) is equal to the total current leaving the junction.

Kirchhoff's Voltage Law (KVL)

□ Definition:

Kirchhoff's Voltage Law (KVL) states that:

- The sum of the voltages around any closed loop in a circuit is always zero.

Star – Delta Connections

1. Star (Y) Connection

□ Definition:

In a **Star** connection, one end of all three components (like windings) is connected to a **common point called the neutral**. The other ends are connected to the **three phases**.

□ Diagram:

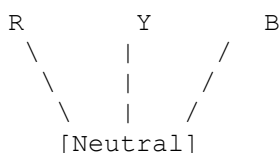

- **Line Voltage (VL) = $\sqrt{3} \times$ Phase Voltage (VP)**
- **Line Current (IL) = Phase Current (IP)**

2. Delta (Δ) Connection

□ Definition:

In a **Delta** connection, all three components are connected **end-to-end to form a closed loop**. Each corner connects to a **phase**.

□ **Diagram:**

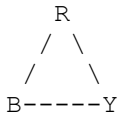

- **Line Voltage (VL) = Phase Voltage (VP)**

Line Current (IL) = $\sqrt{3} \times$ Phase Current (IP)

Star – Delta Conversion

Conversion formulas for Resistances:

	Conversion	Formula
Star \rightarrow Delta		$R_{AB} = R_A + R_B + (R_A \cdot R_B) / R_C$
Delta \rightarrow Star		$R_A = (R_{AB} \cdot R_{AC}) / (R_{AB} + R_B + R_C + R_{CA})$

Mesh and Loop Analysis

What is a Loop?

A **loop** is any **closed path** in a circuit.

What is a Mesh?

A **mesh** is a **smallest possible loop** that **does not enclose other loops** inside it.

All meshes are loops, but not all loops are meshes.

Mesh Analysis (Mesh Current Method)

Definition:

Mesh analysis is a method that uses **KVL (Kirchhoff's Voltage Law)** to write equations for **each mesh (independent loop)** in a circuit to find unknown currents.

Put into Eq.1:

$$-6(74I_2)+4I_2=-10 \Rightarrow -424I_2+4I_2=-10 \Rightarrow -10.5I_2+4I_2=-10 \Rightarrow -6.5I_2=-10 \Rightarrow I_2=1.538A \Rightarrow I_1=74 \times 1.538=2.692A$$

Final Mesh Currents:

- $I_1 \approx 2.69 \text{ A}$
- $I_2 \approx 1.54 \text{ A}$

Loop Analysis

Loop analysis is similar but **includes all loops**, even overlapping ones. It's more general but often **more complex** than mesh analysis.

Mesh vs Loop Analysis

Feature	Mesh Analysis	Loop Analysis
Basis	Smallest loops (meshes)	All closed loops
Equations	Less	More
Best suited for	Planar circuits	All circuits
Involves	Only mesh currents	Loop currents (can overlap)

Electrical Power Rating

Electrical components are given a “power rating” in watts that indicates the maximum rate at which the component converts the electrical power into other forms of energy such as heat, light or motion. For example, a 1/4W resistor, a 100W light bulb etc.

Electrical devices convert one form of power into another. So for example, an electrical motor will convert electrical energy into a mechanical force, while an electrical generator converts mechanical force into electrical energy. A light bulb converts electrical energy into both light and heat.

Also, we now know that the unit of power is the *WATT*, but some electrical devices such as electric motors have a power rating in the old measurement of “Horsepower” or hp. The relationship between horsepower and watts is given as: 1hp = 746W. So for example, a two-horsepower motor has a rating of 1492W, (2 x 746) or 1.5kW.

Ohms Law Pie Chart

To help us understand the the relationship between the various values a little further, we can take all of the Ohm’s Law equations from above for finding Voltage, Current, Resistance and of course Power and condense them into a simple **Ohms Law pie chart** for use in AC and DC circuits and calculations as shown.

Ohms Law Pie Chart

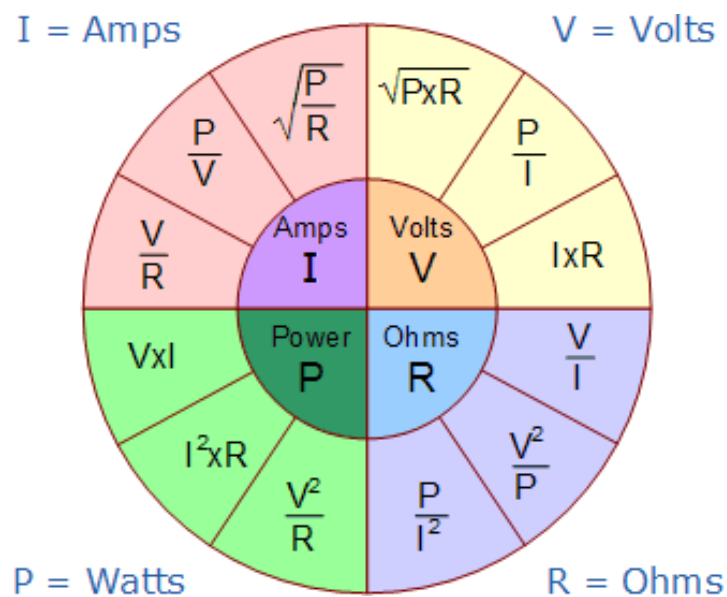

As well as using the *Ohm’s Law Pie Chart* shown above, we can also put the individual Ohm’s Law equations into a simple matrix table as shown for easy reference when calculating an unknown value.

Ohms Law Matrix Table

Ohms Law Formulas				
Known Values	Resistance (R)	Current (I)	Voltage (V)	Power (P)
Current & Resistance	---	---	$V = I \times R$	$P = I^2 \times R$
Voltage & Current	$R = \frac{V}{I}$	---	---	$P = V \times I$
Power & Current	$R = \frac{P}{I^2}$	---	$V = \frac{P}{I}$	---
Voltage & Resistance	---	$I = \frac{V}{R}$	---	$P = \frac{V^2}{R}$
Power & Resistance	---	$I = \sqrt{\frac{P}{R}}$	$V = \sqrt{P \times R}$	---
Voltage & Power	$R = \frac{V^2}{P}$	$I = \frac{P}{V}$	---	---

Ohms Law Example No1

For the circuit shown below find the Voltage (V), the Current (I), the Resistance (R) and the Power (P).

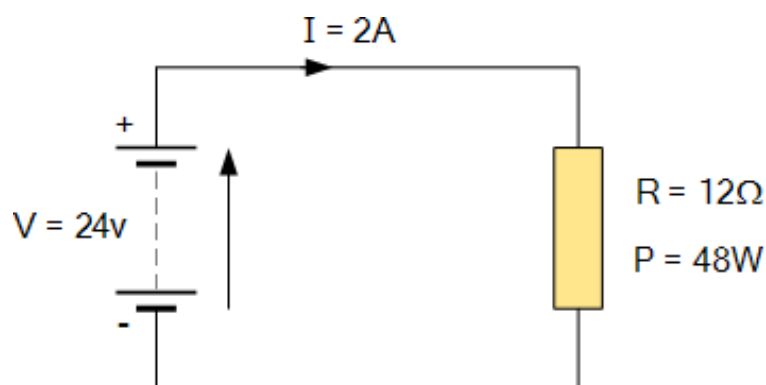

$$\text{Voltage } [V = I \times R] = 2 \times 12\Omega = 24V$$

$$\text{Current } [I = V \div R] = 24 \div 12\Omega = 2A$$

$$\text{Resistance } [R = V \div I] = 24 \div 2 = 12 \Omega$$

$$\text{Power } [P = V \times I] = 24 \times 2 = 48W$$

Power within an electrical circuit is only present when **BOTH** voltage and current are present. For example, in an open-circuit condition, voltage is present but there is no current flow $I = 0$ (zero), therefore $V \times 0$ is 0 so the power dissipated within the circuit must also be 0. Likewise, if we have a

short-circuit condition, current flow is present but there is no voltage $V = 0$, therefore $0 \times I = 0$ so again the power dissipated within the circuit is 0.

As electrical power is the product of $V \times I$, the power dissipated in a circuit is the same whether the circuit contains high voltage and low current or low voltage and high current flow. Generally, electrical power is dissipated in the form of **Heat** (heaters), **Mechanical Work** such as motors, **Energy** in the form of radiated (Lamps) or as stored energy (Batteries).

Electrical Energy in Circuits

Electrical Energy is the capacity to do work, and the unit of work or energy is the **joule (J)**. Electrical energy is the product of power multiplied by the length of time it was consumed. So if we know how much power, in Watts is being consumed and the time, in seconds for which it is used, we can find the total energy used in watt-seconds. In other words, Energy = power x time and Power = voltage x current. Therefore electrical power is related to energy and the unit given for electrical energy is the watt-seconds or *joules*.

$$\text{Electrical Energy} = \text{Power (W)} \times \text{Time (s)}$$

Electrical power can also be defined as the rate of by which energy is transferred. If one joule of work is either absorbed or delivered at a constant rate of one second, then the corresponding power will be equivalent to one watt so power can be defined as "1Joule/sec = 1Watt". Then we can say that one watt is equal to one joule per second and electrical power can be defined as the rate of doing work or the transferring of energy.

Electrical Power and Energy Triangle

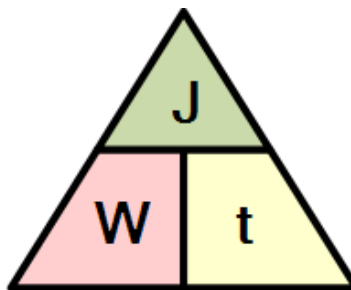

or to find the various individual quantities:

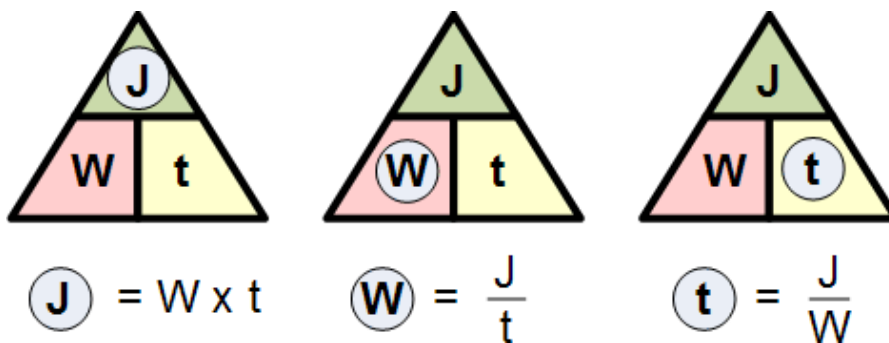

We said previously that electrical energy is defined as being watts per second or *joules*. Although electrical energy is measured in Joules it can become a very large value when used to calculate the energy consumed by a component.

For example, if a 100 watt light bulb is left-“ON” for 24 hours, the energy consumed will be 8,640,000 Joules (100W x 86,400 seconds), so prefixes such as **kilojoules** (kJ = 10^3 J) or **megajoules** (MJ = 10^6 J) are used instead and in this simple example, the energy consumed will be 8.64MJ (mega-joules).

But dealing with joules, kilojoules or megajoules to express electrical energy, the maths involved can end up with some big numbers and lots of zero's, so it is much more easier to express electrical energy consumed in Kilowatt-hours.

If the electrical power consumed (or generated) is measured in watts or kilowatts (thousands of watts) and the time is measure in hours not seconds, then the unit of electrical energy will be the **kilowatt-hours**,(kWhr). Then our 100 watt light bulb above will consume 2,400 watt hours or 2.4kWhr, which is much easier to understand the 8,640,000 joules.

1 kWhr is the amount of electricity used by a device rated at 1000 watts in one hour and is commonly called a “Unit of Electricity”. This is what is measured by the utility meter and is what we as consumers purchase from our electricity suppliers when we receive our bills.

Kilowatt-hours are the standard units of energy used by the electricity meter in our homes to calculate the amount of electrical energy we use and therefore how much we pay. So if you switch ON an electric fire with a heating element rated at 1000 watts and left it on for 1 hour you will have consumed 1 kWhr of electricity. If you switched on two electric fires each with 1000 watt elements for half an hour the total consumption would be exactly the same amount of electricity – 1kWhr.

So, consuming 1000 watts for one hour uses the same amount of power as 2000 watts (twice as much) for half an hour (half the time). Then for a 100 watt light bulb to use 1 kWhr or one unit of electrical energy it would need to be switched on for a total of 10 hours ($10 \times 100 = 1000 = 1\text{kWhr}$).

Now that we know what is the relationship between voltage, current and resistance in a circuit, in the next tutorial relating to DC Circuits, we will look at the Standard Electrical Units used in electrical and electronic engineering to enable us to calculate these values and see that each value can be represented by either multiples or sub-multiples of the standard unit.

Temperature Coefficient Of Resistance

Usually, the temperature affects the resistance and electrical resistivity of all materials. Further, when there is a change in electrical resistance it has a great bearing on different electrical and electronic circuits. There could also be instances where we will witness significant changes. Due to this factor, the temperature coefficient of resistance is an important topic that we should understand in many electrical applications.

Table of Contents

- Relation between Temperature and Resistances
- Types of Temperature Coefficient Of Resistance

What is Temperature Coefficient of Resistance?

The temperature coefficient of resistance is generally defined as the change in electrical resistance of a substance with respect to per degree change in temperature.

So if we look at the electrical resistance of conductors such as gold, aluminium, silver, copper, it all depends upon the process of collision between the electrons within the material. When the temperature increases, the process of electron collision becomes rapid and faster. As a result, the resistance will increase with the rise in temperature of the conductor.

Relation between Temperature and Resistances

Let us consider a conductor whose resistance at 0°C is R_0 and the resistance at a temperature $T^\circ\text{C}$ is R_T . The relation between temperature and resistances R_0 and R_T is approximately given as

$$R_T = R_0 [1 + \alpha (T - T_0)]$$

$$R_T = R_0 [1 + \alpha (\Delta T)]$$

Hence it is clear from the above equation that the change in **electrical resistance** of any substance due to temperature depends mainly on three factors –

1. The value of resistance at an initial temperature.
2. The rise in temperature.
3. The temperature coefficient of resistance α .

The value of α can vary depending on the type of material. In metals, as the temperature increases the electrons attain more kinetic energy, thus more speed to undergo frequent collisions. When the temperature of the metal is increased, the average velocity of the current carriers i.e. the electrons increases and result in more collisions.

Types of Temperature Coefficient Of Resistance

There are two main types of temperature coefficient of resistance.

Positive Temperature Coefficient Of Resistance

The resistivity and the resistance of the material increases due to decrease in τ . Hence the value of the temperature coefficient of metal is positive.

Negative Temperature Coefficient Of Resistance

In the case of **semiconductors** and **insulators**, the number of charge carriers per unit volume increases with an increase in temperature.

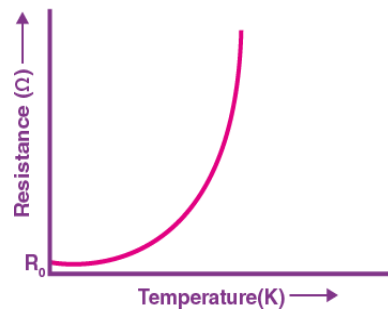

The curve in figure 1 shows that the value of resistance increases with an increase in temperature. The value of resistance at zero units of temperature is represented as R_0 .

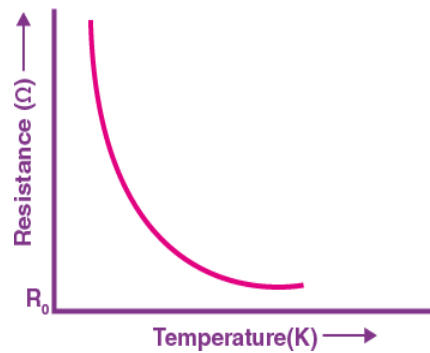

The curve in figure 2 represents the typical nature of the resistance of a semiconductor as a function of temperature.

Material	Temperature coefficient of resistance / 0°C (at 200°C)
Iron (Fe)	0.00651
Aluminium (Al)	0.00429
Gold (Au)	0.0034
Silver (Ag)	0.0038
Platinum (Pt)	0.003927
Copper (Cu)	0.00386
Tin (Sn)	0.0042
Tungsten (W)	0.0045
Silicon (Si)	- 0.07

Brass	0.0015
Nickel (Ni)	0.00641
Mercury (Hg)	0.0009

Solved Questions

Question 1: The resistance of a wire is 5Ω at 50°C and 6Ω at 100°C . The resistance of the wire at 0°C will be?

Solution:

We know that $R_T = R_0 [1 + \alpha (T - T_0)]$

$$5 = R_0 [1 + 50\alpha] \dots\dots\dots (1)$$

$$6 = R_0 [1 + 100\alpha] \dots\dots\dots (2)$$

Dividing equation (1) and (2)

$$5/6 = 1 + 50\alpha / 1 + 100\alpha$$

$$\alpha = 1/200$$

From (1)

$$5 = R_0 [1 + 50(1/200)]$$

$$R_0 = 4\Omega$$

Question 2: The resistance of a bulb filament is 100Ω at a temperature of 100°C . If its temperature coefficient of resistance be 0.005 per $^\circ\text{C}$, its resistance will become 200Ω at a temperature of?

Solution:

As we know that $R_T = R_0 [1 + \alpha (T - T_0)]$

$$100 = R_0 [1 + 0.005 \times 100]$$

$$\text{And } 200 = R_0 [1 + 0.005 \times T]$$

Here T is the temperature in $^\circ\text{C}$ at which the resistance becomes 200Ω .

$$200/100 = (1 + 0.005 \times T) / (1 + 0.005 \times 100)$$

$$T = 400^\circ\text{C}$$

Question 3: A platinum resistance thermometer has a resistance $R_0 = 40.0\Omega$ at $T_0 = 30^\circ\text{C}$. α for Pt. is $3.92 \times 10^{-3} (^\circ\text{C})^{-1}$. The thermometer is immersed in a vessel containing melting tin, at which point R increases to 94.6Ω . What is the melting point of tin?

Given:

$$R_0 = 40.0\Omega, R_T = 94.6\Omega$$

$$T_0 = 30^\circ\text{C}, T = ?$$

Solution:

$$R_T = R_0 [1 + \alpha (T - T_0)]$$

$$94.6\Omega = 40\Omega [1 + 3.92 \times 10^{-3} (^\circ\text{C})^{-1} (T - 30^\circ\text{C})]$$

$$2.365 = [1 + 3.92 \times 10^{-3} (^\circ\text{C})^{-1} (T - 30^\circ\text{C})]$$

$$1.365 = 3.92 \times 10^{-3} (^\circ\text{C})^{-1} (T - 30^\circ\text{C})$$

$$211.0^\circ\text{C} = T - 30^\circ\text{C}$$

$$T = 241^\circ\text{C}$$

The melting point of tin is 241°C .

Resistivity

Resistivity of materials is the resistance to the flow of an electric current with some materials resisting the current flow more than others

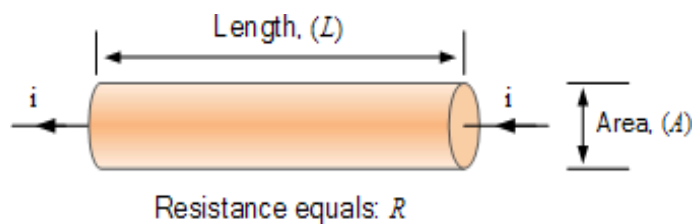

Ohms Law states that when a voltage (V) source is applied between two points in a circuit, an electrical current (I) will flow between them encouraged by the presence of the potential difference between these two points. The amount of electrical current which flows is restricted by the amount of resistance (R) present. In other words, the voltage encourages the current to flow (the movement of charge), but it is resistance that discourages it.

A Single Conductor

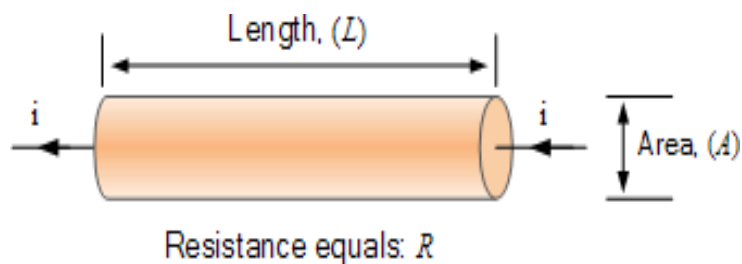

The electrical resistance, R of this simple conductor is a function of its length, L and the conductors area, A. Ohms law tells us that for a given resistance R, the current flowing through the conductor is proportional to the applied voltage as $I = V/R$. Now suppose we connect two identical conductors together in a series combination as shown.

Doubling the Length of a Conductor

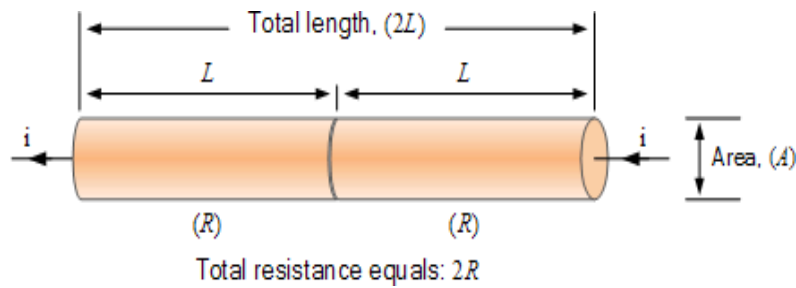

Here by connecting the two conductors together in a series combination, that is end to end, we have effectively doubled the total length of the conductor ($2L$), while the cross-sectional area, A remains exactly the same as before. But as well as doubling the length, we have also doubled the total resistance of the conductor, giving $2R$ as: $1R + 1R = 2R$.

Therefore we can see that the resistance of the conductor is proportional to its length, that is: $R \propto L$. In other words, we would expect the electrical resistance of a conductor (or wire) to be proportionally greater the longer it is.

Note also that by doubling the length and therefore the resistance of the conductor ($2R$), to force the same current, i to flow through the conductor as before, we need to double (increase) the applied voltage as now $I = (2V)/(2R)$. Next suppose we connect the two identical conductors together in parallel combination as shown.

Doubling the Area of a Conductor

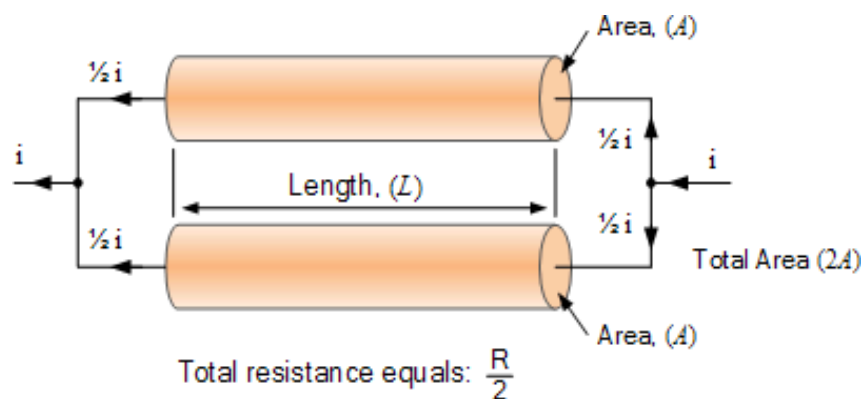

Here by connecting the two conductors together in a parallel combination, we have effectively doubled the total area giving $2A$, while the conductors length, L remains the same as the original single conductor. But as well as doubling the area, by connecting the two conductors together in parallel we have effectively halved the total resistance of the conductor, giving $1/2R$ as now each half of the current flows through each conductor branch.

Thus the resistance of the conductor is inversely proportional to its area, that is: $R \propto 1/A$, or $R \propto 1/A$. In other words, we would expect the electrical resistance of a conductor (or wire) to be proportionally less the greater is its cross-sectional area.

Also by doubling the area and therefore halving the total resistance of the conductor branch ($1/2R$), for the same current, i to flow through the parallel conductor branch as before we only need half (decrease) the applied voltage as now $V = (1/2V)/(1/2R)$.

So hopefully we can see that the resistance of a conductor is directly proportional to the length (L) of the conductor, that is: $R \propto L$, and inversely proportional to its area (A), $R \propto 1/A$. Thus we can correctly say that resistance is:

Proportionality of Resistance

$$R \propto \frac{L}{A}$$

But as well as length and conductor area, we would also expect the electrical resistance of the conductor to depend upon the actual material from which it is made, because different conductive materials, copper, silver, aluminium, etc all have different physical and electrical properties.

Thus we can convert the proportionality sign (\propto) of the above equation into an equals sign simply by adding a "proportional constant" into the above equation giving:

Electrical Resistivity Equation

$$R = \rho \left(\frac{L}{A} \right) \Omega$$

Where: R is the resistance in ohms (Ω), L is the length in metres (m), A is the area in square meters (m^2), and where the proportional constant ρ (the Greek letter "rho") is known as Resistivity.

Electrical Resistivity

The electrical resistivity of a particular conductor material is a measure of how strongly the material opposes the flow of electric current through it. This resistivity factor, sometimes called its "specific electrical resistance", enables the resistance of different types of conductors to be compared to one another at a specified temperature according to their physical properties without regards to their lengths or cross-sectional areas. Thus the higher the resistivity value of ρ the more resistance and vice versa.

For example, the resistivity of a good conductor such as copper is on the order of 1.72×10^{-8} ohm meters (or $17.2 \text{ n}\Omega\text{m}$), whereas the resistivity of a poor conductor (insulator) such as air can be well over 1.5×10^{14} or 150 trillion Ωm .

Materials such as copper and aluminium are known for their low levels of resistivity thus allowing electrical current to easily flow through them making these materials ideal for making electrical

wires and cables. Silver and gold have much low resistivity values, but for obvious reasons are more expensive to turn into electrical wires.

Then the factors which affect the resistance (R) of a conductor in ohms can be listed as:

The **resistivity (ρ)** of the material from which the conductor is made.

The total **length (L)** of the conductor.

The cross-sectional **area (A)** of the conductor.

The temperature of the conductor.

Resistors And Its Types

Resistors:-

Resistors are the most fundamental and commonly used component in all the electronic circuits. The main function of a resistor within an electrical or electronic circuit is to oppose or resist the flow of current, hence named as **resistor** .

The symbol of resistor is shown in fig. below.



Resistance is measured in units called “**Ohm**”.

Resistors can be broadly of **two types**.

1. Fixed Resistors
2. Variable Resistors

Fixed Resistors

A fixed resistor is one for which the value of its resistance is specified or fixed and cannot be varied in general.

Example of fixed resistors are :

1. **Carbon Film Resistors** : These are made of carbon dust or graphite paste and have low wattage values.
2. **Metal Film Resistors** : These are made from conductive metal oxide paste and have very low wattage values.
3. **Wire wound resistors** : These resistors have metallic bodies for heat sink mounting and have very high wattage ratings.

Carbon Film Resistors:-

This is the most general purpose, cheap resistor used in electrical and electronic circuits.



Carbon Film Resistor

Their resistive element is manufactured from a mixture of finely ground carbon dust or graphite (similar to pencil lead) and a non-conducting ceramic (clay) powder to bind it all together.

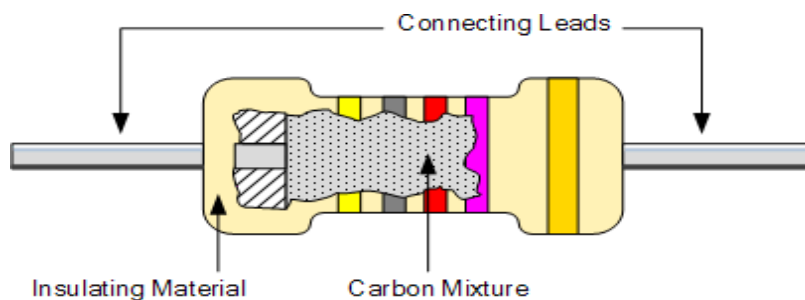

The ratio of carbon dust to ceramic i.e. conductor to insulator, determines the overall resistive value and the higher the ratio of carbon, the lower the overall resistance.

The mixture is then moulded into a cylindrical shape with metal wires or leads attached to each end to provide the electrical connection. Then finally it is coated with an outer insulating material and colour coded markings to denote its resistive value.

Usually the tolerance of the resistance value is $\pm 5\%$. Such resistors with power ratings of 1/8W, 1/4W and 1/2W are frequently used.

The disadvantage of using carbon film resistors is that they tend to be electrically noisy.

Metal Film Resistors:-

Metal film resistors are used when a higher tolerance (more accurate value) is needed.



Metal film Resistor

Nichrome (Ni-Cr) is generally used for the material of resistor.

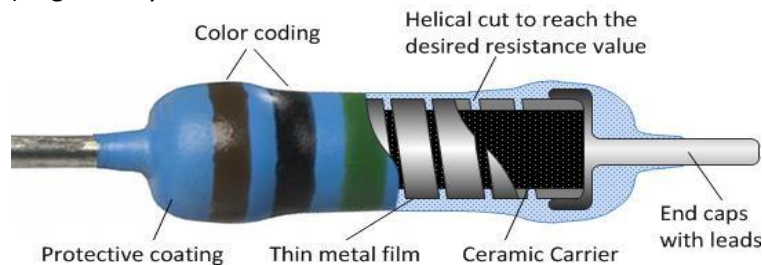

They are much more accurate in value than carbon film resistors. They have about $\pm 0.05\%$ tolerance.

Wire wound Resistor



Wire Wound Resistor:-

A wire wound resistor is made of metal resistance wire, and because of this, they can be manufactured to precise values. Also, high-wattage resistors can be made by using a thick wire material. Wire wound resistors cannot be used for high frequency circuits.

Other types of Resistors:-

Ceramic Resistor

Another type of resistor is the Ceramic resistor. These are wire wound resistors in a ceramic case, strengthened with a special cement.



Ceramic Resistor

They have very high power ratings, from 1 or 2 watts to dozens of watts.

These resistors can become extremely hot when used for high power applications, and this must be taken into account when designing the circuit.

Single-In Line Network Resistors

It is made with many resistors of the same value, all in one package.

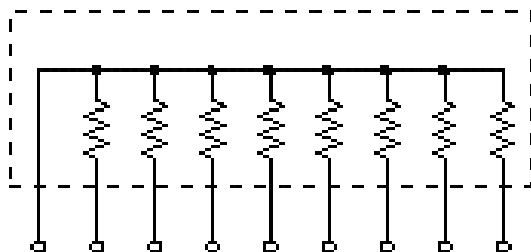

Single-in Line Network Resistor

One side of each resistor is connected with one side of all the other resistors inside.

One example of its use is to control the current in a circuit powering many light emitting diodes (LEDs).

In the fig. below, 8 resistors are housed in the package. Each of the leads on the package is one resistor. The ninth lead on the left side is the common lead.

4S-Resistor Network

The 4S indicates that the package contains 4 independent resistors that are not wired together inside. The housing has eight leads instead of nine.

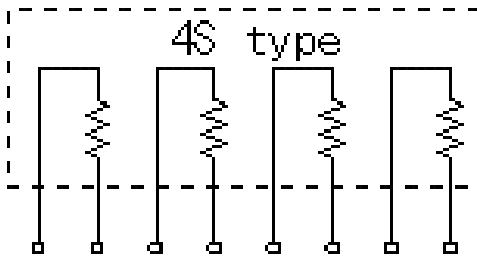

4s- Resistor Network

Variable Resistors

There are two general ways in which variable resistors are used.

One is the variable resistor whose value is easily changed.

The other is semi-fixed resistor that is not meant to be adjusted by anyone but a technician. It is used to adjust the operating condition of the circuit by the technician.

Semi-fixed resistors are used to compensate for the inaccuracies of the resistors, and to fine-tune a circuit. The rotation angle of the variable resistor is usually about 300 degrees. Some variable resistors must be turned many times(multi-turn Pot) to use the whole range of resistance they offer. This allows for very precise adjustments of their value. These are called "Potentiometers" or "Trimmer Potentiometers" or "presets".



Variable Resistors

The four resistors at the center are the semi-fixed type. The two resistors on the left are the trimmer potentiometers

There are three ways in which a variable resistor's value can change according to the rotation angle of its axis. When type "A" rotates clockwise, at first, the resistance value changes slowly and then in the second half of its axis, it changes very quickly. It is well suited to adjust a low sound subtly. They are sometimes called "audio taper" potentiometers.

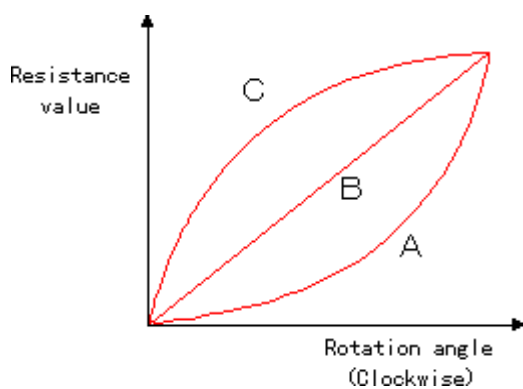
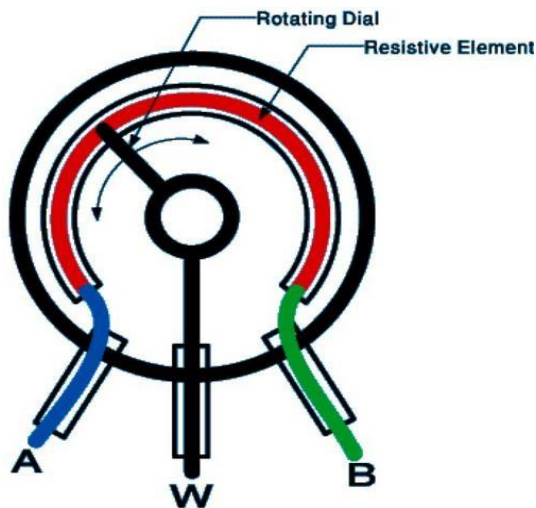

In type "B" the rotation of the axis and the change of the resistance value are directly related. The rate of change is the same, or linear, throughout the sweep of the axis. This type suits a resistance value adjustment in a circuit, a balance circuit and so on. They are sometimes called "linear taper" potentiometers.

Type "C" changes exactly the opposite way to type "A". In the early stages of the rotation of the axis, the resistance value changes rapidly, and in the second half, the change occurs more slowly. As for the variable resistor, most are type "A" or type "B".

Resistor Color Code

In our previous post we saw that there are many different types of **Resistor** available that can be used in both electrical and electronic circuits.

The resistance value is a discrete value. For example, the values 1, 2.2, 4.7 and 10 are used in a typical situation.

Since the average resistor is too small to have the value printed on it, the resistance value is displayed using the color code (the colored bars/the colored stripes).

Resistor Color Coding

This is an international and universally accepted method, developed many years ago as a simple and quick way of identifying a resistors ohmic value no matter what its size or condition.

It consists of a set of individual colored rings or bands in spectral order representing each digit of the resistors value.

The resistor color code markings are always read one band at a time starting from the left to the right, with the larger width tolerance band oriented to the right side indicating its tolerance.

By matching the color of the first band with its associated number in the digit column of the color chart below the first digit is identified and this represents the first digit of the resistance value.

Again, by matching the color of the second band with its associated number in the digit column of the color chart we get the second digit of the resistance value and so on.

Standard Resistor Color Code Chart

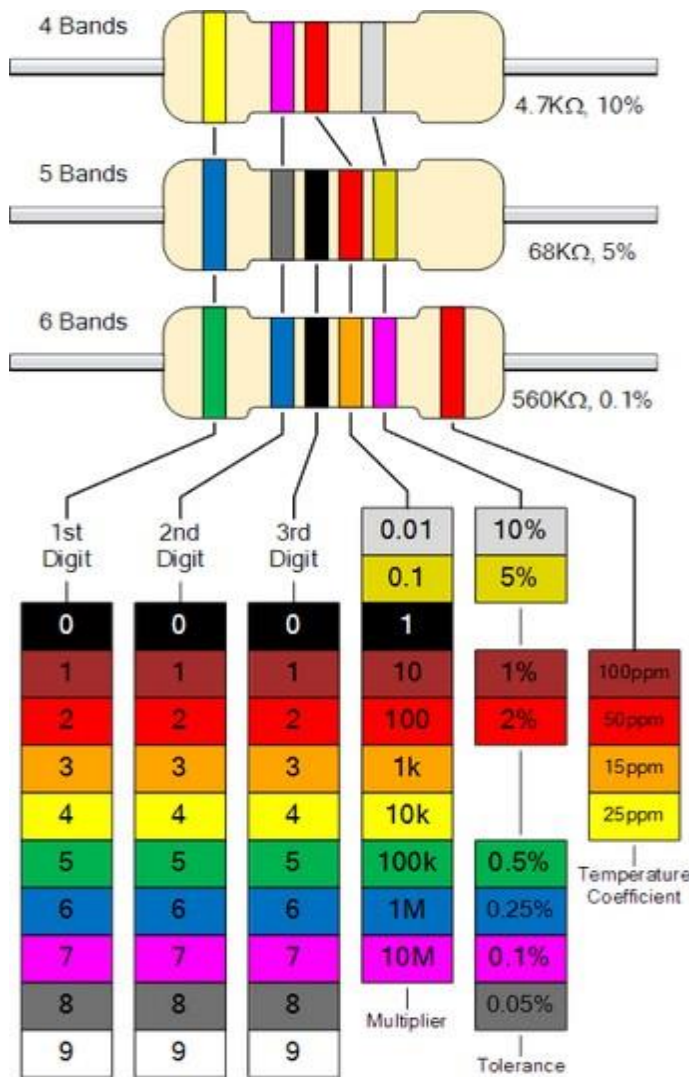

Resistor Color Code Table

Colour	Digit	Multiplier	Tolerance
Black	0	1	
Brown	1	10	± 1%
Red	2	100	± 2%
Orange	3	1,000	
Yellow	4	10,000	
Green	5	100,000	± 0.5%
Blue	6	1,000,000	± 0.25%
Violet	7	10,000,000	± 0.1%
Grey	8		± 0.05%
White	9		
Gold		0.1	± 5%
Silver		0.01	± 10%
None			± 20%

Calculating Resistor Values

In order to calculate the correct value of resistance, the following method is used in a color code system :

The left-hand or the most significant colored band is the band which is nearest to a connecting lead with the color coded bands being read from left-to-right as follows;

Digit, Digit, Multiplier = Color, Color x 10^{color} in Ohm's (Ω 's)

Example 1 :

Let us take a resistor which has the following colored markings;

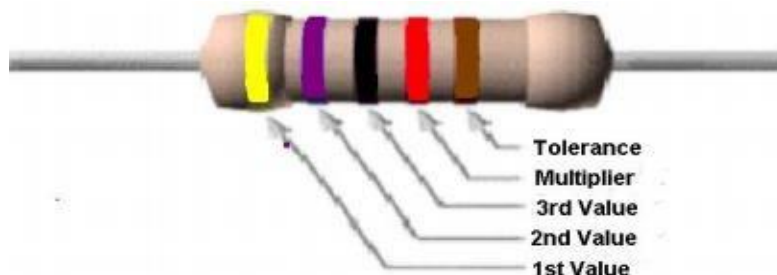

Resistance = Yellow, Violet, Black, Red = 4, 7, 0,2 = $470 \times 10^2 = 4700\Omega$ or 47 k Ω

The fifth bands is used to determine the percentage tolerance of the resistor.

Hence, Tolerance (Brown)= ±1%

Tolerance of the resistor is also an important property to consider. A 100 Ω resistor with 10% tolerance, means that its value can be any fixed value between 90 to 110 ohms.

Hence the resistor tolerance can be defined as a measure of the resistors variation from the specified resistive value and is a consequence of the manufacturing process and is expressed as a percentage of its "nominal" or preferred value.

If resistor has no fourth tolerance band then the default tolerance would be at 20%.

Example 2:

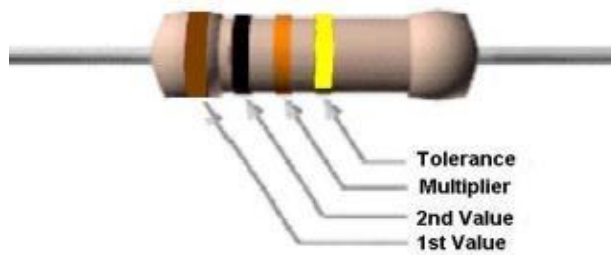

Resistance = Brown, Black, Orange = 1, 0, 3 = $10 \times 10^3 = 10 \text{ k}\Omega$
 Tolerance(Gold) = $\pm 5\%$

Resistors in Series and Parallel Combinations

In our previous post about resistors, we studied about different types of resistors.

In some cases when we do not get the desired or specific resistor values we have to either use variable resistors such as potentiometers or presets to obtain such precise values. However, such pots are too expensive to use for every case.

Another method to do this, is to combine two or more resistors to obtain the necessary precise values. Such resistor combinations cost very less.

Now the question arises as to how one should combine these resistors.

The resistors can be combined in two different ways such as :

1. Series Combinations
2. Parallel combinations

Resistors in Series

Resistors are said to be connected in “**Series**”, when they are daisy chained together in a single line. Calculating values for two or more resistors in series is simple, just add all the values up.

The series connection ensures that the **SAME** current flows through all resistors.

In this type of connection R_{Total} will always be **GREATER** than any of the included resistors.

The total resistance is the sum of all the resistors connected in series and is given by the expression :

$$R_{\text{Total}} = R_1 + R_2 + R_3 + \dots$$

Example :

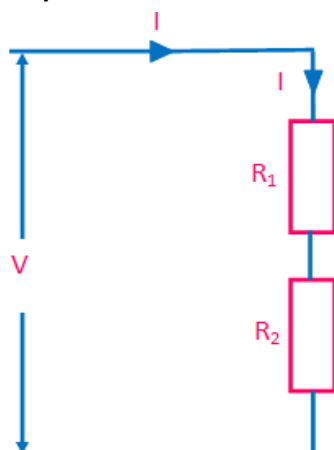

- As the resistors are connected together in series, the same current passes through each resistor in the chain and the total resistance, R_{Total} of the circuit must be **equal** to the sum of all the individual resistors added together. That is

$$R_{\text{Total}} = R_1 + R_2$$

- The total applied voltage V is divided by the two resistors.
- The current in the circuit is given as:

$$I = \frac{V}{R_1 + R_2}$$

- Using Ohm's Law, the voltages across R_1 and R_2 are given as :

$$V_1 = I \times R_1 = \left(\frac{V}{R_1 + R_2}\right) \times R_1$$

$$V_2 = I \times R_2 = \left(\frac{V}{R_1 + R_2}\right) \times R_2$$

- Hence, the total voltage is given as :

$$V = V_1 + V_2 = \left(\frac{V}{R_1 + R_2}\right) \times R_1 + \left(\frac{V}{R_1 + R_2}\right) \times R_2$$

- For example if we take $V = 6\text{ V}$, $R_1 = 1\text{ k}\Omega$ and $R_2 = 2\text{ k}\Omega$, then

$$R_{\text{Total}} = 1\text{ k}\Omega + 2\text{ k}\Omega = 3\text{ k}\Omega$$

$$I = 6\text{V}/3\text{k}\Omega = 2\text{ mA}$$

$$\text{Voltage across the } 1\text{ k}\Omega \text{ resistor is } V_1 = 2\text{ mA} \times 1\text{ k}\Omega = 2\text{ V}$$

$$\text{Voltage across the } 2\text{ k}\Omega \text{ resistor is } V_2 = 2\text{ mA} \times 2\text{ k}\Omega = 4\text{ V}$$

So we see that we can replace the two individual resistors above with just one single "equivalent" resistor which will have a value of $3\text{ k}\Omega$.

This total resistance is generally known as the **Equivalent Resistance** and can be defined as; "*a single value of resistance that can replace any number of resistors in series without altering the values of the current or the voltage in the circuit*".

The series connection can be characterized by the following points :

1. The same current flows through all the resistors connected in series.
2. The resultant resistor is the SUM of all resistors in series.
3. Series resistors divide the total applied voltage proportional to their magnitude.

Voltage Divider Circuit

Since the series resistors divide voltage, this idea can be used to get smaller voltage from a power supply output.

For example, we have a power supply with 10V fixed output. But we want only 5V from it. How to get it ?

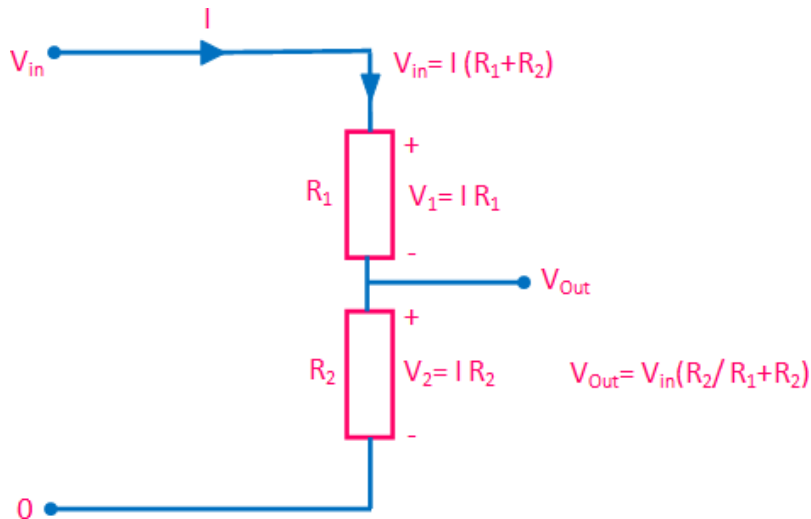

The circuit shown above consists of two resistors, R_1 and R_2 connected together in series across the supply voltage V_{in} .

The current I is given by:

$$I = \frac{V_{in}}{R_1 + R_2}$$

Since the current I flows through R_1 as well as R_2 , hence, by using Ohm's law, the voltage developed across R_2 is given by :

$$V_{Out} = \left(\frac{V_{in}}{R_1 + R_2}\right)R_2$$

$$V_{Out} = \left(\frac{R_2}{R_1 + R_2}\right)V_{in}$$

If $R_1 = R_2$, then $V_{out} = V_{in} / 2$

If more resistors are connected in series to the circuit then different voltages will appear across each resistor in turn with regards to their individual resistance values providing different but smaller voltage points from one single supply.

Resistors in Parallel

Resistors are said to be connected together in "**Parallel**" when both of their terminals are respectively connected to each terminal of the other resistor or resistors.

Parallel Combination

The fig. below shows the circuit of resistors in parallel combination where two resistors R_1 and R_2 are connected in parallel across the supply voltage E .

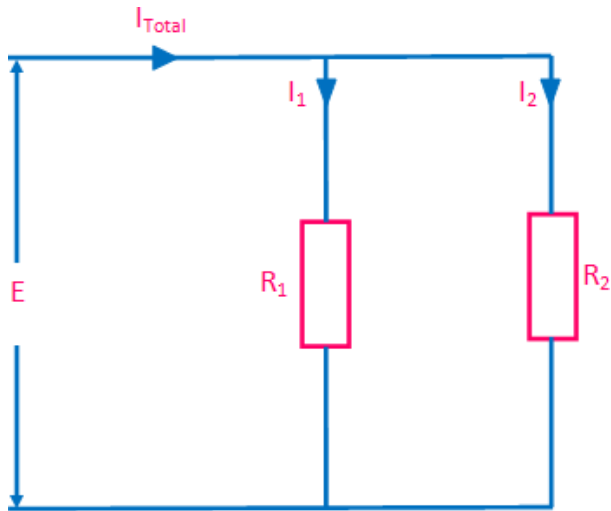

As we can see from the fig. above :

- There are two paths available for Current. Hence current divides.
- But voltage across the resistors are the same.
- If the two resistors are equal the current will divide equally and the R_{Total} will be exactly half of either resistor or exactly one third if there are three equal resistors.
- In general we can say :

$$\frac{1}{R_{Total}} = \frac{1}{R_1} + \frac{1}{R_2} + \dots$$

$$R_{Total} = \frac{R_1 R_2 \dots}{R_1 + R_2 + \dots}$$

Currents in a Parallel Resistor Circuit

In a parallel resistor circuit the voltage remains same across each resistor connected in parallel. However, the current through each parallel resistor is not necessarily the same since the value of the resistance in each branch determines the current within that branch.

The total current, I_{Total} in a parallel resistor circuit is the sum of the individual currents flowing in all the parallel branches which can be determined by using Ohm's law.

Example

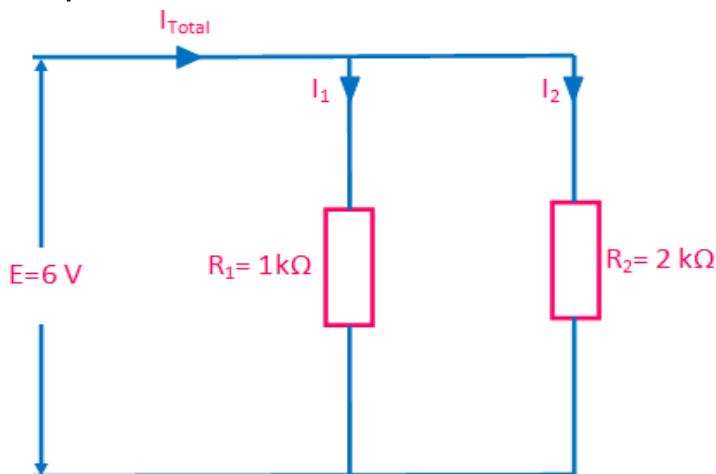

Let's take the voltage E be 6V.

The resistors be $R_1 = 1 \text{ k}\Omega$ and $R_2 = 2 \text{ k}\Omega$.

By using Ohm's law, the current through $R_1 = 6 \text{ V} / 1 \text{ k}\Omega = 6 \text{ mA}$ and current through $R_2 = 6 \text{ V} / 2 \text{ k}\Omega = 3 \text{ mA}$

Hence the total current is $6 \text{ mA} + 3 \text{ mA} = 9 \text{ mA}$

6 V will generate 9 mA only when the total resistance of the circuit is equal to :

$$6 \text{ V} / 9 \text{ mA} = 0.66 \text{ k}\Omega$$

Hence the effective resistance of R_1 and R_2 connected in parallel is $0.66 \text{ k}\Omega$.

This effective resistance can also be calculated by using the formula as below :

$$R_{Total} = \frac{R_1 R_2}{R_1 + R_2}$$

$$R_{Total} = \frac{1 \text{ k}\Omega \times 2 \text{ k}\Omega}{1 \text{ k}\Omega + 2 \text{ k}\Omega} = \frac{2 \times 10^6 \Omega}{3 \times 10^3 \Omega} = 0.66 \text{ k}\Omega$$

Thus the parallel connection can be characterized by :

1. The same voltage exists across all the resistors connected in parallel .
2. The reciprocal of resultant or total resistance is the sum of reciprocals of all resistors in parallel .
3. Parallel resistors divide the total current in an inverse proportion to their magnitude.
4. When a set of resistors are connected in parallel, the effective resistance is always smaller than the smallest in the set.

For example: Let $1 \text{ k}\Omega$ and $10 \text{ k}\Omega$ resistors are in parallel .

Then the resultant is $(1 \text{ k} \times 10 \text{ k}) / 11 \text{ k} = 0.9 \text{ k}\Omega$, which is smaller than 1 k (the smallest).

Resistors in Series and Parallel Combinations

In some electrical and electronic circuits it is required to connect various resistors together in "BOTH" parallel and series combinations within the same circuit and produce more complex resistive networks.

Now the question arises, how do we calculate the combined or total circuit resistance, currents and voltages for these resistive combinations.

Resistor circuits that combine series and parallel resistors networks together are generally known as **Resistor Combination** or mixed resistor circuits.

The method of calculating the circuits equivalent resistance is the same as that for any individual series or parallel circuit.

The most important thing to keep in mind in such calculations is that resistors in series carry exactly the same current and that resistors in parallel have exactly the same voltage across them.

Example

Let us consider the circuit shown in fig. below :

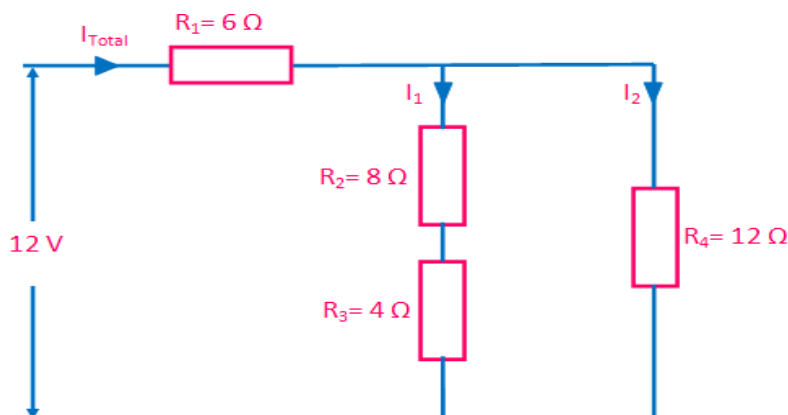

In the above circuit let us calculate the total current (I_T) taken from the 12 v supply. We can see that the two resistors, R_2 and R_3 are actually connected in a “SERIES” combination so we can add them together to produce an equivalent resistance. The resultant resistance for this combination would therefore be:

$$R_2 + R_3 = 8 \Omega + 4 \Omega = 12 \Omega$$

So we can replace both resistor R_2 and R_3 above with a single resistor of resistance value 12Ω as shown in fig. below:

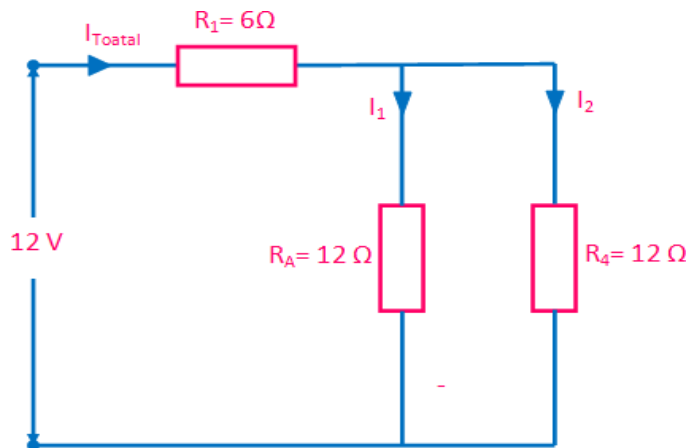

So our circuit now has a single resistor R_A in “PARALLEL” with the resistor R_4 . Using our resistors in parallel equation we can reduce this parallel combination to a single equivalent resistor value of $R_{(combination)}$ using the formula for two parallel connected resistors as follows.

$$R_{combination} = \frac{R_A R_4}{R_A + R_4}$$

$$= \frac{12 \times 12}{12 + 12} = \frac{144}{24} = 6 \Omega$$

The resultant resistive circuit now looks something like this:

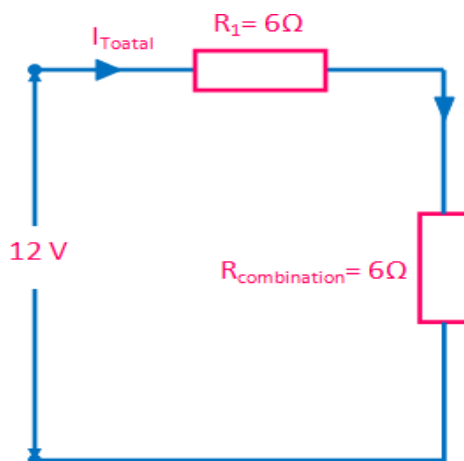

We can see that the two remaining resistances, R_1 and $R_{(combination)}$ are connected together in a “SERIES” combination and again they can be added together (resistors in series) so that the total circuit resistance therefore given as:

$$R_{Equivalent} = R_1 + R_{combination} = 6 + 6 = 12 \Omega$$

A single resistance of just 12Ω can be used to replace the original four resistors connected together in the original circuit.

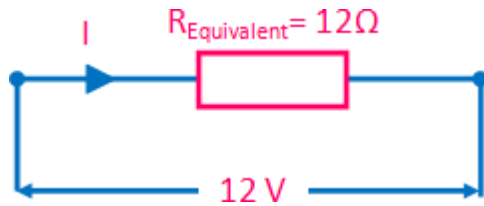

Now by using Ohm's law, the value of the circuit current (I) is simply calculated as:

$$I = \frac{V}{R} = \frac{V}{R_{Equivalent}} = \frac{12V}{12\Omega} = 1A$$

What Is A Capacitor & What Are The Various Types of Capacitors

What Is A Capacitor

Capacitors are simple passive devices which are used to store electricity. The capacitor has the ability or "capacity" to store energy in the form of an electrical charge producing a potential difference (*Static Voltage*) across its plates, much like a small rechargeable battery.

Capacitor Symbol

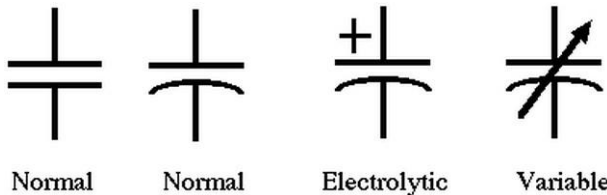

Normal

Normal

Electrolytic

Variable

A capacitor is formed from two conducting plates separated by air or by some form of a good insulating material such as waxed paper, mica, ceramic, plastic or some form of a liquid gel. The insulating layer between a capacitor's plates is commonly called the **Dielectric**.

Due to this insulating layer, the d.c. current can not flow through the capacitor but instead a voltage is produced across the plates in the form of an electrical charge.

If a current i flows, positive charge, q , will accumulate on the upper plate. To preserve charge neutrality, a balancing negative charge will be present on the lower plate.

Hence, there will be a potential energy difference (or voltage v) between the plates which is proportional to the charge q .

$$v = \frac{d}{A\epsilon} \times q$$

where A is the area of the plates

d is their separation

ϵ_0 is the permittivity of the insulating layer ($\epsilon_0 = 8.85 \text{ pF/m}$ for vacuum).

The capacitance is given by the following expression :

$$C = \frac{A\epsilon}{d}$$

The capacitance is measured in Farads (F)

The charge q is hence given by the expression :

$$q = C \times v$$

The current, i , which is the rate of charge flow is given by :

$$i = \frac{dq}{dt} = C \frac{dv}{dt}$$

The conductive metal plates of a capacitor can be either square, circular or rectangular, or they can be of a cylindrical or spherical shape with the general shape, size and construction of a parallel plate capacitor depending on its application and voltage rating.

When used in a direct current or DC circuit, a capacitor charges up to its supply voltage but blocks the flow of current through it because the dielectric. However, when a capacitor is connected to an alternating current or AC circuit, the flow of the current appears to pass straight through the capacitor with little or no resistance.

Types of Capacitors

There are a large variety of different types of capacitor available in the market with their own set of characteristics and applications, from very small delicate trimming capacitors up to large power metal-can type capacitors used in high voltage power correction and smoothing circuits.

Capacitor types are distinguished by the material used as the insulator.

Let us now discuss a few common types of capacitor available.

Dielectric Capacitor

Dielectric capacitors are usually of the variable type where a continuous variation of capacitance is required for tuning transmitters, receivers and transistor radios.

Variable Capacitor Symbol



Variable Capacitor Symbol

Variable dielectric capacitors are multi-plate air-spaced types that have a set of fixed plates (the stator vanes) and a set of movable plates (the rotor vanes) which move in between the fixed plates. The position of the moving plates with respect to the fixed plates determines the overall capacitance value.

The capacitance is generally at maximum when the two sets of plates are fully meshed together. High voltage type tuning capacitors have relatively large spacings or air-gaps between the plates with breakdown voltages reaching many thousands of volts.



Film Capacitor

Film Capacitors are the most commonly available of all types of capacitors

These capacitors have a relatively large family with the difference being in their dielectric properties which include polyester (Mylar), polystyrene, polypropylene, polycarbonate, metalised paper, Teflon etc.

Film type capacitors are available in capacitance ranges from as small as 5pF to as large as 100uF .

Film Capacitors which use polystyrene, polycarbonate or Teflon as their dielectrics are sometimes called "Plastic capacitors". The main advantage of plastic film capacitors compared to impregnated-paper types is that they operate well under conditions of high temperature, have smaller tolerances, a very long service life and high reliability.

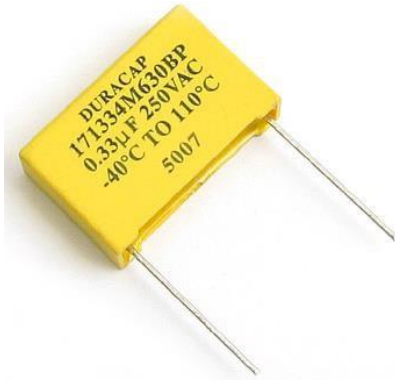

Ceramic Capacitors

Ceramic Capacitors or Disc Capacitors are made by coating two sides of a small porcelain or ceramic disc with silver and are then stacked them together .

For very low capacitance values a single ceramic disc of about 3-6mm is used.

Ceramic capacitors have a high dielectric constant and are used so that relatively high capacitance can be obtained in a small physical size. Ceramic capacitors have values ranging from a few picofarads to one or two microfarads (μF).

They exhibit large non-linear changes in capacitance against temperature and hence, used as de-coupling or by-pass capacitors as they are also non-polarized devices.

Ceramic types of capacitors generally have a 3-digit code printed onto their body to identify their capacitance value in pico-farads. Generally the first two digits indicate the capacitors value and the third digit indicates the number of zero's to be added. For example, a ceramic disc capacitor with the markings 103 would indicate 10 and 3 zero's in pico-farads which is equivalent to 10,000 pF or 10nF. Letter codes are sometimes used to indicate their tolerance value such as: J = 5%, K = 10% or M = 20% etc.



Electrolytic Capacitors

Electrolytic Capacitors are generally used when very large capacitance values are required.



Here instead of using a very thin metallic film layer for one of the electrodes, a semi-liquid electrolyte solution in the form of a jelly or paste is used which serves as the second electrode (usually the cathode).

The dielectric is a very thin layer of oxide which is grown electro-chemically in production with the thickness of the film being less than ten microns. This insulating layer is so thin that it is possible to make capacitors with a large value of capacitance for a small physical size as the distance between the plates, d is very small.

Most of the electrolytic types of capacitors are Polarised, which means the DC voltage applied to the capacitor terminals must be of the correct polarity, i.e. positive to the positive terminal and negative to the negative terminal as an incorrect polarisation will break down the insulating oxide layer and permanently damage the capacitor.

Hence, all polarised electrolytic capacitors have their polarity clearly marked with a negative sign to indicate the negative terminal and this polarity must be followed.

Electrolytic Capacitors are generally used in DC power supply circuits due to their large capacitance's and small size to help reduce the ripple voltage or for coupling and decoupling applications.

One main disadvantage of electrolytic capacitors is their relatively low voltage rating and due to the polarisation of electrolytic capacitors, which means that they must not be used on AC supplies.

The other drawbacks of electrolytic capacitors are large leakage currents, value tolerances, equivalent series resistance and a limited lifetime.

Electrolytic capacitors can be either wet-electrolyte or solid polymer.

They are commonly made of tantalum or aluminum, although other materials may be used.

Supercapacitors are a special subtype of electrolytic capacitors, also called double-layer electrolytic capacitors, with capacitances of hundreds and thousands of farads.

Electrolytic capacitors generally come in two basic forms ;

1. **Aluminium Electrolytic Capacitors**
2. **Tantalum Electrolytic Capacitors**

1. Aluminium Electrolytic Capacitors



There are basically two types of Aluminium Electrolytic Capacitor, the plain foil type and the etched foil type.

The thickness of the aluminium oxide film and high breakdown voltage give these capacitors very high capacitance values for their size.

The foil plates of the capacitor are anodized with a DC current. This anodizing process sets up the polarity of the plate material and determines which side of the plate is positive and which side is negative.

The etched foil type differs from the plain foil type in that the aluminium oxide on the anode and cathode foils has been chemically etched to increase its surface area and permittivity.

This gives a smaller sized capacitor than a plain foil type of equivalent value but has the disadvantage of not being able to withstand high DC currents compared to the plain type. Also their tolerance range is quite large at up to 20%.

Typical values of capacitance for an aluminium electrolytic capacitor range from 1 μ F up to 47,000 μ F. Etched foil electrolytic's are best used in coupling, DC blocking and by-pass circuits while plain foil types are better suited as smoothing capacitors in power supplies.

2. Tantalum Electrolytic Capacitors



Tantalum Electrolytic Capacitors are available in both wet (foil) and dry (solid) electrolytic types with the dry or solid tantalum being the most common.

Solid tantalum capacitors use manganese dioxide as their second terminal and are physically smaller than the equivalent aluminium capacitors.

The dielectric properties of tantalum oxide is also much better than those of aluminium oxide giving a lower leakage currents and better capacitance stability which makes them suitable for use in blocking, by-passing, decoupling, filtering and timing applications.

Also, Tantalum Capacitors although polarised, can tolerate being connected to a reverse voltage much more easily than the aluminium types but are rated at much lower working voltages.

Solid tantalum capacitors are usually used in circuits where the AC voltage is small compared to the DC voltage.

However, some tantalum capacitor types contain two capacitors in-one, connected negative-to-negative to form a "non-polarised" capacitor for use in low voltage AC circuits as a non-polarised device.

Generally, the positive lead is identified on the capacitor body by a polarity mark, with the body of a tantalum bead capacitor being an oval geometrical shape.

Typical values of capacitance range from 47nF to 470 μ F.

Capacitors In Series and Parallel Combinations

[CAPACITORS](#) BY [SASMITA](#) OCTOBER 12, 2015

Capacitors in Series and Parallel Combinations

Capacitors are one of the standard components in electronic and electrical circuits. However, complicated combinations of capacitors mostly occur in practical circuits.

It is, therefore, useful to have a set of rules for finding the equivalent capacitance of some general capacitors arrangements.

The equivalent capacitance of any complicated arrangement can be determined by the repeated application of two simple rules and these rules are related to capacitors connected in series and in parallel.

Capacitors in Series

Capacitors are said to be connected in series, when they are effectively daisy chained together in a single line.

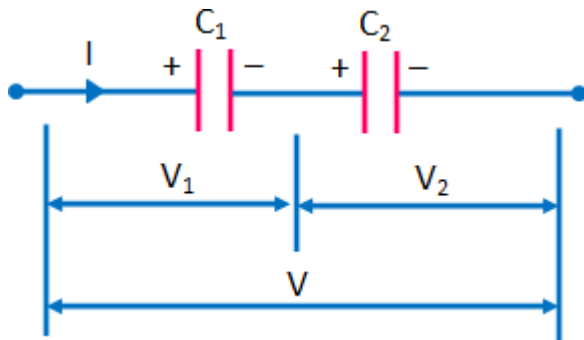

Consider two capacitors connected in *series*: *i.e.* in a line such that the positive plate of one is attached to the negative plate of the other as shown in the fig. above.
 In fact, let us suppose that the positive plate of capacitor 1 is connected to the input wire, the negative plate of capacitor 1 is connected to the positive plate of capacitor 2, and the negative plate of capacitor 2 is connected to the output wire.

Now the question arises, what is the equivalent capacitance between the input and output wires? In this connection, it is important to realize that the charge Q stored in the two capacitors is same. This can be explained as follows :

Let us consider the internal plates *i.e.*, the negative plate of capacitor 1, and the positive plate of capacitor 2.

These plates are physically disconnected from the rest of the circuit, so the total charge on them must remain constant.

Assuming, that these plates carry zero charge when zero potential difference is applied across the two capacitors, it follows that in the presence of a non-zero potential difference the charge Q on the positive plate of capacitor 2 must be balanced by an equal and opposite charge $-Q$ on the negative plate of capacitor 1.

Since the negative plate of capacitor 1 carries a charge $-Q$, the positive plate of capacitor 2 carries a charge $+Q$ to balance it.

As a result, both capacitors possess the same stored charge Q .

The potential drops, V_1 and V_2 , across the two capacitors different.

However, the sum of these drops equals the total potential drop V applied across the input and output wires:

$$V = V_1 + V_2$$

i.e.

$$C_{eq} = Q/V$$

The equivalent capacitance of the pair of capacitors is again $C_{eq} = Q/V$. Thus,

$$\begin{aligned} \frac{1}{C_{eq}} &= \frac{V}{Q} = \frac{V_1 + V_2}{Q} \\ &= \frac{V_1}{Q} + \frac{V_2}{Q} = \frac{1}{C_1} + \frac{1}{C_2} \end{aligned}$$

Hence,

$$\frac{1}{C_{eq}} = \frac{1}{C_1} + \frac{1}{C_2}$$

Hence, we can conclude that :

The reciprocal of the equivalent capacitance of two capacitors connected in series is the sum of the reciprocals of the individual capacitances.

For N capacitors connected in series, the equivalent capacitance equation can be generalized to :

$$1/C_{eq} = \sum_{i=1}^N (1/C_i).$$

Example

Find the overall capacitance and the individual rms voltage drops across the two capacitors each with 47 nF, in series when connected to a 12V a.c. supply.

Solution :

Total Capacitance,

$$C_T = \frac{C_1 \times C_2}{C_1 + C_2} = \frac{47 \text{ nF} \times 47 \text{ nF}}{47 \text{ nF} + 47 \text{ nF}} = 23.5 \text{ nF}$$

Voltage drop across the two identical 47 nF capacitors,

$$V_{C1} = \frac{C_2}{C_1 + C_2} \times V_T = \frac{47 \text{ nF}}{47 \text{ nF} + 47 \text{ nF}} \times 12 \text{ V} = 6 \text{ V}$$

$$V_{C2} = \frac{C_1}{C_1 + C_2} \times V_T = \frac{47 \text{ nF}}{47 \text{ nF} + 47 \text{ nF}} \times 12 \text{ V} = 6 \text{ V}$$

Capacitors in Parallel

Capacitors are said to be connected in parallel when both of their terminals are respectively connected to each terminal of the other capacitor or capacitors.

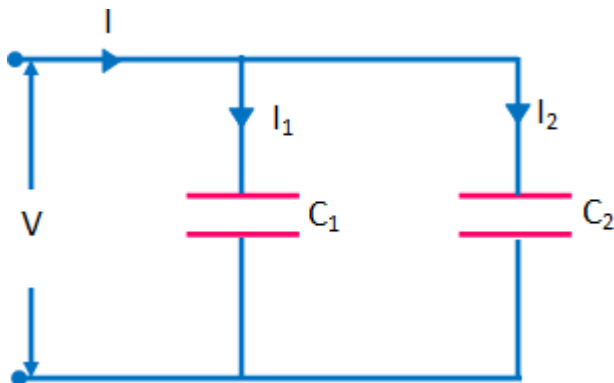

Consider two capacitors connected in *parallel*: i.e., with the positively charged plates connected to a common input wire, and the negatively charged plates attached to a common output wire as shown in the above fig.

What is the equivalent capacitance between the input and output wires?

In this case, the potential difference V across the two capacitors is the same, and is equal to the potential difference between the input and output wires.

However, the total stored charge Q is divided between the two capacitors, since it must distribute itself such that the voltage across them is same.

Since, the capacitors may have different capacitances, C_1 and C_2 , the

charges Q_1 and Q_2 may also be different.

The equivalent capacitance C_{eq} of the pair of capacitors is simply the ratio Q/V ,

$$Q = Q_1 + Q_2$$

where Q is the total stored charge.

It follows that :

$$C_{eq} = \frac{Q}{V} = \frac{Q_1 + Q_2}{V} = \frac{Q_1}{V} + \frac{Q_2}{V}$$

Hence,

$$C_{eq} = C_1 + C_2$$

In general for we can say that :

The equivalent capacitance of two capacitors connected in parallel is the sum of the individual capacitances.

For N capacitors connected in parallel, the equation for equivalent capacitance can be generalized to :

$$C_{eq} = \sum_{i=1}^N C_i$$

Example :

Calculate the combined capacitance of the following capacitors each with a capacitance of 47 nF, when they are connected together in a parallel combination .

Solution :

Total Capacitance,

$$C_T = C_1 + C_2 = 47 \text{ nF} + 47 \text{ nF} = 94 \text{ nF}$$

Magnetic Effects of Electric Current

If you have been to a bank, you must have noticed that banks have a locker, or take the example of hotel doors. Both the places use a magnetic lock and are controlled by either a number secret code or a magnetic card, which when swiped opens the door. So how is a magnetic safe or lock better than normal locks? How does it work? Well, it works on the principals of 'Magnetic Effects of Electric Current'. But what are these effects? Let us study more about magnetic effects of electric current.

- [Magnetic Field and Magnetic Force](#)
- [Electromagnetic Induction and Its Applications](#)
- [Domestic Electric Currents](#)

Magnetic field and Magnetic force

'Opposites attract'. You must have heard this phrase quite often. But why do opposites attract? Where did this phrase originate from? This phrase comes from the magnet and its magnetic field. The opposite poles of a magnet attract each other. In actuality shouldn't opposite poles repel and like poles attract each other? Isn't it? 'No' you say. Well, then let us prove your theory below.

What is Magnetism?

A bar magnet attracts iron objects to its ends, called **poles**. One end is the **north pole**, and the other is the **south pole**. Magnetism is the phenomena arising from the force caused by magnets that produce fields which attract or repel other metallic objects. It is caused because of electrically charged particles. The force acting on the electrically charged particles in a magnetic field depends on the magnitude of the charge, the velocity of the particle, and its strength. Magnetism states that:

- Opposite poles attract.**
- Like poles repel.**

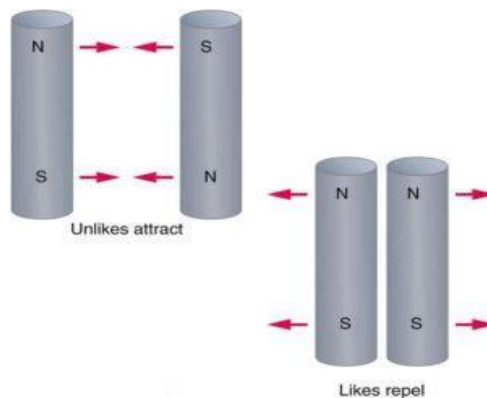

If two bar magnets are brought close together, the like poles will repel each other, and the unlike poles attract each other.

Magnetic field

When a positively charged particle moves in a uniform magnetic field, then the direction of the velocity of the particle is perpendicular to the field. The magnetic force always acts in a direction perpendicular to the motion of the charge. The space or the region around a magnet within which magnetic force is exerted on other magnet is called as the **magnetic field**.

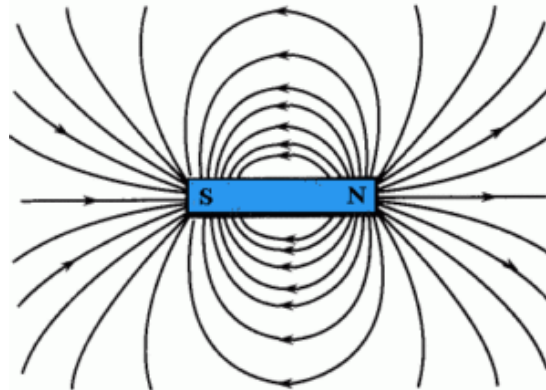

To locate the magnetic field of a bar magnet, we use a magnetic compass. When a magnetic compass is kept away from the magnet, it doesn't deflect. When a magnetic compass is brought closer to the magnet it deflects. If the magnetic field lines are very close to each other in a particular region, then the strength of the magnetic field is very strong, and if the magnetic field lines are far away then the magnetic field is very weak.

It is expressed in the unit **Tesla**.

Magnetic force

The magnetic force is the force of attraction or repulsion that arises between electrically charged particles due to their motion. The magnetic force between two moving charges may be described as the force exerted upon their charge by the magnetic field created by the other. This force causes the magnets to attract or repel one another.

Examples of magnetic force is a compass, a motor, the magnets that hold stuff on the refrigerator, train tracks, and new roller coasters. All moving charges give rise to a magnetic field and the charges that move through its regions, experience a force. It may be positive or negative depending on whether the force is attractive or repulsive. The magnetic force is based on the charge, velocity and magnetic field of the object.

Force on a moving charge

If a charge moves through a magnetic field at an angle, it will experience a force. The equation is given by

$\mathbf{F} = q\mathbf{v}\mathbf{B} \sin \theta$, where q is the charge, \mathbf{B} is the magnetic field, \mathbf{v} is the velocity, and θ is the angle between the directions of the magnetic field and the velocity. **The motion of charge q moving with the velocity \mathbf{v} in a magnetic field, has a force acting on it and this force is:**

- proportional to the charge q
- proportional to the velocity \mathbf{v}
- perpendicular to both \mathbf{v} and \mathbf{B}
- perpendicular to $\sin\theta$ where θ is the angle between \mathbf{v} and \mathbf{B}

Right-Hand Rule

The **direction of the force (\mathbf{F})** can be found from the Right-hand rule.

It applies to the devices that use motion in a magnetic field to generate currents.

- Point your **index finger along the direction of motion of charge \mathbf{v}**
- Rotate your middle finger away from your index finger between \mathbf{v} and \mathbf{B}
- Hold your thumb perpendicular to the plane formed by your index finger and middle finger**
- Your thumb will then point in the direction of the force (\mathbf{F}) if the charge q is positive.*

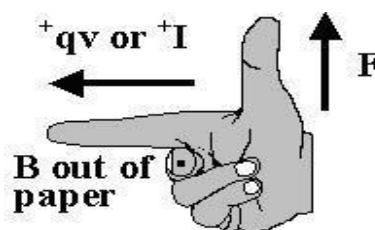

Example :-

Q.Determine the magnetic force of 50 C charged particles moving with the velocity of 3m/s in a magnetic field of 1T? The direction of its field is same as the path of the second particle.

Sol: Given parameters, $q= 50\text{C}$, $v= 3\text{m/s}$ and $B= 1\text{T}$

Since the path difference of the second particle is same as its field's direction,

Therefore, $\theta=0^\circ$

The magnitude force formula is
 $F = q v B \sin\theta = 50 \times 3 \times 1 \times \sin\theta = 0$

Domestic Electric Circuits

What is electricity? Today, electricity has become an essential part of our lives and its hard to imagine life without it. Our households are full of electrical appliances such as an electric bulb, electric bell, electric fan, iron, electric heater, refrigerator, washing machine, etc. Do you know where does this electricity in our house come from? They come from 'electric circuits'. So, let us study more about electric circuits below.

What is an electric circuit?

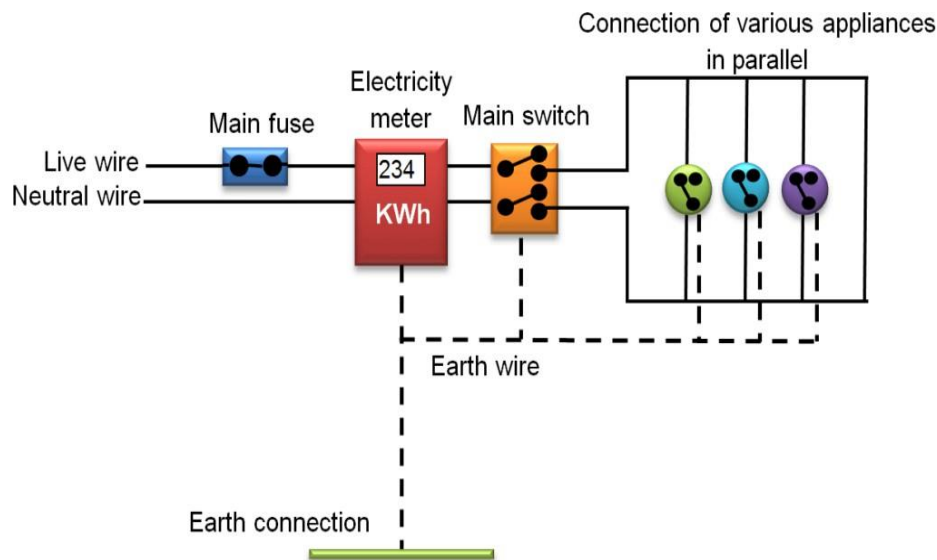

In our homes, either the overhead electric poles or underground cables support the power supply flowing through the main supply. One of the wires in this supply covered with insulation in the color red is the **live wire** (or positive), and another wire colored black is the **neutral wire** (or negative). At the meter-board, these wires pass into an electric meter through the main fuse. The main switch, live wire, and the neutral wire are in connection to the line wires in our homes; these wires then supply electricity to separate electric circuits within the house.

How does the distribution of electricity happen?



The spinning turbines produce electricity, that flows into the power lines and to our homes. Electricity moves through the wires very fast. In just a second, electricity can travel around the world several times. From the power station where the electricity is produced, it flows to large transmission lines held up by huge towers. The transmission lines carry large amounts of electricity to substations in cities and towns.

Distribution lines carry small amounts of electricity from the substations to houses. When we turn on the TV, electricity flows through wires inside the set, producing pictures, and sound. Three-phase electrical generation and transmission are an efficient and common use of the conductors as each conductor can utilize its current-rating fully in transporting power from generation through transmission and its distribution can occur for final use.

The metallic assemblage of an electric iron, toaster, table fan, fridge, constitutes the earth wire, giving a low-protection directing way for the current. In this way, it guarantees that any leakage of the current from the metallic body of the machine keeps its capability to that of the earth, and the person doesn't get a serious electric shock. Various appliances constitute live and impartial wires.

From electric poles situated in our street, **two insulated wires L and N** come to our house. These **two wires are called Neutral wire and Livewire the potential of these two wires are zero volts and 220V.**

Electric fuse

An electric fuse is used as a safety device for the protection of electric circuits and appliances due to short-circuiting or overloading of the electric circuits. The electric fuse is a piece of wire having a very low melting point and high resistance. When a high current flows through the electric circuits due to short circuit or overloading, the fuse wire heats up and melts. The circuit is broken and the current stops flowing thereby saving the electric circuits and appliance from any damages. The capacities of fuse wire are rated as 1A, 2A, 3A, 5A, 10A, and 15A. An electric composes pure tin or alloy of copper and tin.

Safety measures:-

Insulation

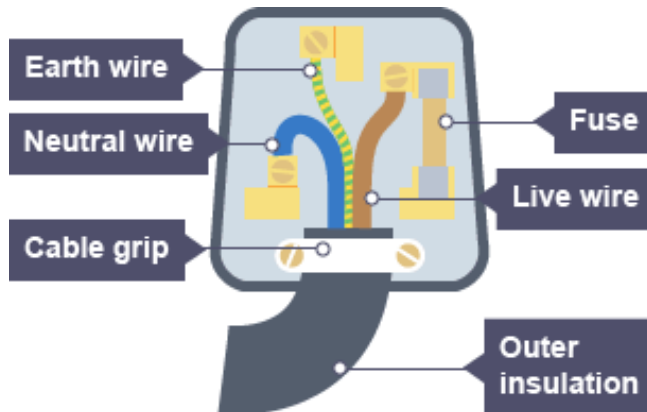

The materials which have very high resistivity offer a very high **resistance** to the flow of the electric current and are insulating materials. These materials play an important role in the domestic wiring as they protect us from shock and also prevent the leakage of the current. Insulators can withstand overloading within permissible limits for a short period of time. They should have the following properties:

- High thermal resistance.
- Insulators should be fireproof.
- They should be durable and readily available.
- Insulators must be non-absorbent of moisture.

Earthing

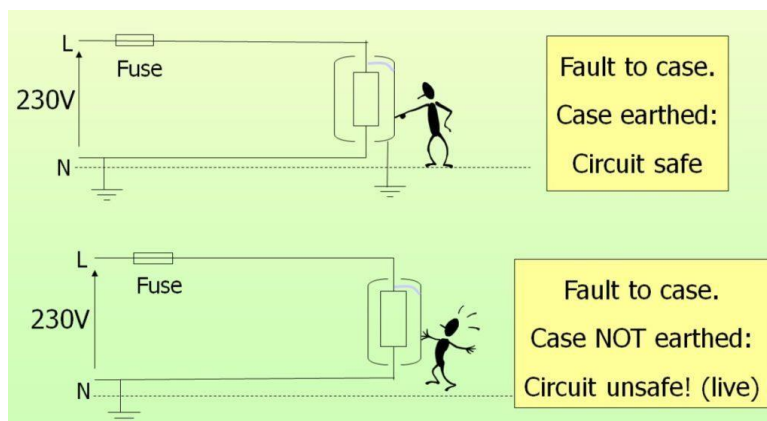

When an iron box is in use, the metallic body's current increases to 110V. If we accidentally come in contact with such a metallic body we are sure to get an electric shock. To avoid shock due to current leakage in electrical appliances the metallic body of the appliance should be in

connection with the earth/ground. Suppose due to some defect, the insulation of the live wire inside iron burns, then the live wire may touch the metallic body of the iron. For this purpose, a separate wire, ‘ **the earth wire**’, runs all through the circuits along with live and neutral wires.

Usually, an electric appliance such as a heater, an iron box, etc. come with the installation of all the three wires namely live, neutral and earth wires. Metal bodies of all the appliances are therefore always in connection with the earth wire. The free end of the earth wire is attached to a copper plate buried deep in the ground. This leaves the body of the electrical appliances at the same potential (zero) as the earth and hence when we touch the metal body we do not get a shock. This is done to avoid accidental shock. Earthing is thus a safety device incorporated in an electric circuit to protect the operator.

Short-circuiting and overloading

- The use of an electric fuse prevents the electric circuit and the appliance from a possible damage by stopping the flow of high electric currents. There are faults in electrical circuits due to which heavy current may flow through the circuit that results in the overheating of live wires. Short-circuiting takes place when a naked live wire touches a naked neutral wire. Normally sub-standard wires wear out soon and may cause short-circuiting.
- Overloading of electrical circuit occurs, when the number of appliances operated on the circuit at the same time exceeds the limits the circuit wiring can withstand. We know that in domestic circuits all the appliances are connected in parallel. In parallel circuits, as we add more and more appliances more current is drawn from the supply. If the total current drawn by all the appliances at a particular time exceeds, the bearing capacity of that wire, the wires of the domestic wiring heat up, leading to ‘**overloading**’. It may happen because of connecting too many devices to the same (one single) socket.

Precautions while using electric circuits

- For household wiring, always use good quality wires having proper thickness and insulation. An ISI mark must be there on any plugs, sockets, switches and electrical appliances in use.
- All the wire connections should be tight and an insulating tape should all the wire connections. Replacement of defective switches, sockets, plugs, etc. must happen immediately.
- The placement of all the switches in your household electrical wiring circuit should happen on the live wire of the circuit so that when the switch it off, the appliance disconnects from the live wire and on touching the device you do not get a shock.
- Switch off the mains before you start working on a repair job on an electrical circuit.

- In case of an electrical accident, switch off the main switch of the electrical supply. Try to insulate the person who has received a shock. In any case, do not touch him directly.
- While earthing and installing a fuse for the household electric circuits, one should be precautious. Ensure that the fuses are placed on live wires and are of proper current rating.

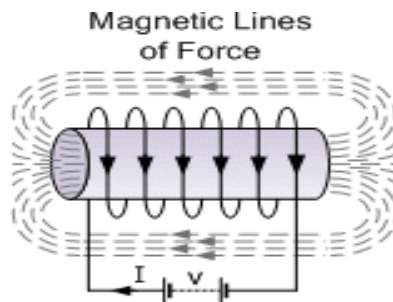

Electromagnetic Induction

When a DC current passes through a long straight conductor a magnetising force and a static magnetic field is developed around it

If the wire is then wound into a coil, the magnetic field is greatly intensified producing a static magnetic field around itself forming the shape of a bar magnet giving a distinct North and South pole.

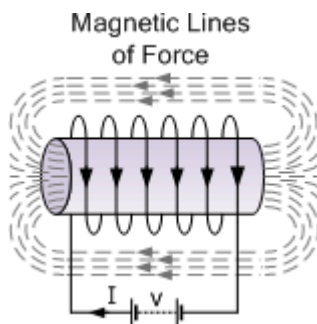

Air-core Hollow Coil

The magnetic flux developed around the coil being proportional to the amount of current flowing in the coils windings as shown. If additional layers of wire are wound upon the same coil with the same current flowing through them, the static magnetic field strength would be increased.

Therefore, the magnetic field strength of a coil is determined by the *ampere turns* of the coil. With more turns of wire within the coil, the greater the strength of the static magnetic field around it.

But what if we reversed this idea by disconnecting the electrical current from the coil and instead of a hollow core we placed a bar magnet inside the core of the coil of wire. By moving this bar magnet “in” and “out” of the coil a current would be induced into the coil by the physical movement of the magnetic flux inside it.

Likewise, if we kept the bar magnet stationary and moved the coil back and forth within the magnetic field an electric current would be induced in the coil. Then by either moving the wire or changing the magnetic field we can induce a voltage and current within the coil and this process is known as **Electromagnetic Induction** and is the basic principle of operation of transformers, motors and generators.

Electromagnetic Induction was first discovered way back in the 1830’s by **Michael Faraday**. Faraday noticed that when he moved a permanent magnet in and out of a coil or a single loop of wire it induced an Electromotive Force or emf, in other words a Voltage, and therefore a current was produced.

So what Michael Faraday discovered was a way of producing an electrical current in a circuit by using only the force of a magnetic field and not batteries. This then lead to a very important law linking electricity with magnetism, **Faraday’s Law of Electromagnetic Induction**. So how does this work?.

When the magnet shown below is moved “towards” the coil, the pointer or needle of the Galvanometer, which is basically a very sensitive centerzero ’ed moving-coil ammeter, will deflect away from its centre position in one direction only. When the magnet stops moving and is held stationary with regards to the coil the needle of the galvanometer returns back to zero as there is no physical movement of the magnetic field.

Likewise, when the magnet is moved “away” from the coil in the other direction, the needle of the galvanometer deflects in the opposite direction with regards to the first indicating a change in polarity. Then by moving the magnet back and forth towards the coil the needle of the galvanometer will deflect left or right, positive or negative, relative to the directional motion of the magnet.

Electromagnetic Induction by a Moving Magnet

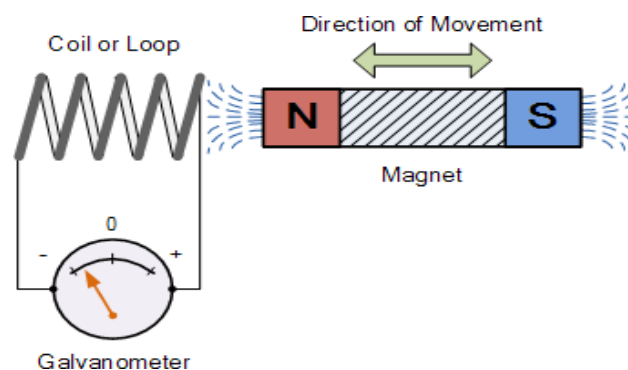

Likewise, if the magnet is now held stationary and ONLY the coil is moved towards or away from the magnet the needle of the galvanometer will also deflect in either direction. Then the action of moving a coil or loop of wire through a magnetic field induces a voltage in the coil with the magnitude of this induced voltage being proportional to the speed or velocity of the movement.

Then we can see that the faster the movement of the magnetic field the greater will be the induced emf or voltage in the coil, so for Faraday's law to hold true there must be "relative motion" or movement between the coil and the magnetic field and either the magnetic field, the coil or both can move.

Faraday's Law of Induction

From the above description we can say that a relationship exists between an electrical voltage and a changing magnetic field to which Michael Faraday's famous law of electromagnetic induction states: "that a voltage is induced in a circuit whenever relative motion exists between a conductor and a magnetic field and that the magnitude of this voltage is proportional to the rate of change of the flux".

In other words, **Electromagnetic Induction** is the process of using magnetic fields to produce voltage, and in a closed circuit, a current.

So how much voltage (emf) can be induced into the coil using just magnetism. Well this is determined by the following 3 different factors.

- 1). Increasing the number of turns of wire in the coil – By increasing the amount of individual conductors cutting through the magnetic field, the amount of induced emf produced will be the sum of all the individual loops of the coil, so if there are 20 turns in the coil there will be 20 times more induced emf than in one piece of wire.
- 2). Increasing the speed of the relative motion between the coil and the magnet – If the same coil of wire passed through the same magnetic field but its speed or velocity is increased, the wire will cut the lines of flux at a faster rate so more induced emf would be produced.
- 3). Increasing the strength of the magnetic field – If the same coil of wire is moved at the same speed through a stronger magnetic field, there will be more emf produced because there are more lines of force to cut.

If we were able to move the magnet in the diagram above in and out of the coil at a constant speed and distance without stopping we would generate a continuously induced voltage that would alternate between one positive polarity and a negative polarity producing an alternating or AC output voltage and this is the basic principle of how an electrical generator works similar to those used in dynamos and car alternators.

In small generators such as a bicycle dynamo, a small permanent magnet is rotated by the action of the bicycle wheel inside a fixed coil. Alternatively, an electromagnet powered by a fixed DC voltage can be made to rotate inside a fixed coil, such as in large power generators producing in both cases an alternating current.

Simple Generator using Magnetic Induction

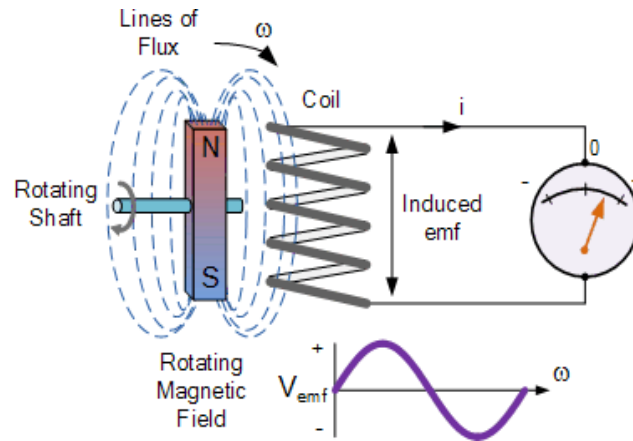

The simple dynamo type generator above consists of a permanent magnet which rotates around a central shaft with a coil of wire placed next to this rotating magnetic field. As the magnet spins, the magnetic field around the top and bottom of the coil constantly changes between a north and a south pole. This rotational movement of the magnetic field results in an alternating emf being induced into the coil as defined by Faraday's law of electromagnetic induction.

The magnitude of the electromagnetic induction is directly proportional to the flux density, β the number of loops giving a total length of the conductor, l in meters and the rate or velocity, v at which the magnetic field changes within the conductor in meters/second or m/s, giving by the motional emf expression:

Faraday's Motional emf Expression

$$\mathcal{E} = -\beta \cdot l \cdot v \text{ volts}$$

If the conductor does not move at right angles (90°) to the magnetic field then the angle θ° will be added to the above expression giving a reduced output as the angle increases:

$$\mathcal{E} = -\beta \cdot l \cdot v \sin\theta \text{ volts}$$

Lenz's Law of Electromagnetic Induction

Faraday's Law tells us that inducing a voltage into a conductor can be done by either passing it through a magnetic field, or by moving the magnetic field past the conductor and that if this conductor is part of a closed circuit, an electric current will flow. This voltage is called an **induced emf** as it has been induced into the conductor by a changing magnetic field due to electromagnetic induction with the negative sign in Faraday's law telling us the direction of the induced current (or polarity of the induced emf).

But a changing magnetic flux produces a varying current through the coil which itself will produce its own magnetic field as we saw in the Electromagnets tutorial. This self-induced emf opposes the change that is causing it and the faster the rate of change of current the greater is the opposing emf. This self-induced emf will, by Lenz's law oppose the change in current in the coil and because of its direction this self-induced emf is generally called a **back-emf**.

Lenz's Law states that: " **the direction of an induced emf is such that it will always opposes the change that is causing it**". In other words, an induced current will always OPPOSE the

motion or change which started the induced current in the first place and this idea is found in the analysis of Inductance.

Likewise, if the magnetic flux is decreased then the induced emf will oppose this decrease by generating an induced magnetic flux that adds to the original flux.

Lenz's law is one of the basic laws in electromagnetic induction for determining the direction of flow of induced currents and is related to the law of conservation of energy.

According to the law of conservation of energy which states that the total amount of energy in the universe will always remain constant as energy can not be created nor destroyed. Lenz's law is derived from Michael Faraday's law of induction.

One final comment about Lenz's Law regarding electromagnetic induction. We now know that when a relative motion exists between a conductor and a magnetic field, an emf is induced within the conductor.

But the conductor may not actually be part of the coils electrical circuit, but may be the coils iron core or some other metallic part of the system, for example, a transformer. The induced emf within this metallic part of the system causes a circulating current to flow around it and this type of core current is known as an **Eddy Current**.

Eddy currents generated by electromagnetic induction circulate around the coils core or any connecting metallic components inside the magnetic field because for the magnetic flux they are acting like a single loop of wire. Eddy currents do not contribute anything towards the usefulness of the system but instead they oppose the flow of the induced current by acting like a negative force generating resistive heating and power loss within the core. However, there are electromagnetic induction furnace applications in which only eddy currents are used to heat and melt ferromagnetic metals.

Eddy Currents Circulating in a Transformer

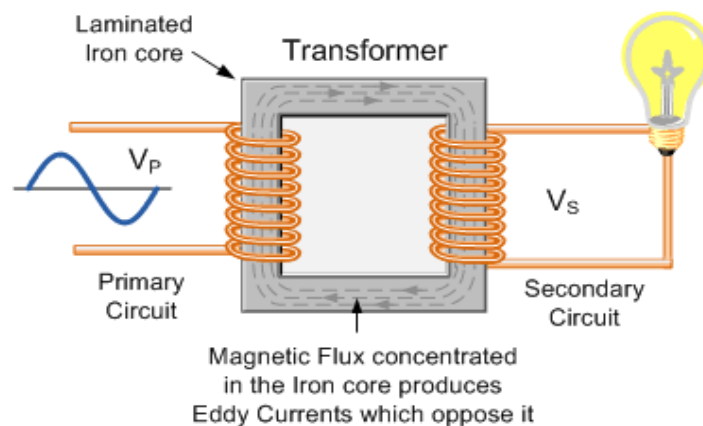

The changing magnetic flux in the iron core of a transformer above will induce an emf, not only in the primary and secondary windings, but also in the iron core. The iron core is a good conductor, so the currents induced in a solid iron core will be large. Furthermore, the eddy currents flow in a direction which, by Lenz's law, acts to weaken the flux created by the primary coil. Consequently, the current in the primary coil required to produce a given B field is increased, so the hysteresis curves are fatter along the H axis.

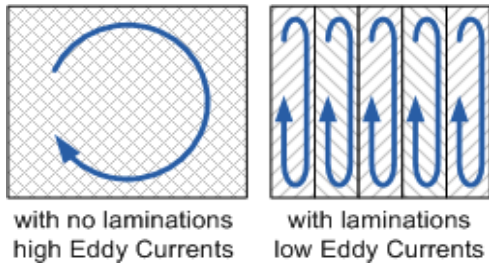

Laminating the Iron Core

Eddy current and hysteresis losses can not be eliminated completely, but they can be greatly reduced. Instead of having a solid iron core as the magnetic core material of the transformer or coil, the magnetic path is “laminated”.

These laminations are very thin strips of insulated (usually with varnish) metal joined together to produce a solid core. The laminations increase the resistance of the iron-core thereby increasing the overall resistance to the flow of the eddy currents, so the induced eddy current power-loss in the core is reduced, and it is for this reason why the magnetic iron circuit of transformers and electrical machines are all laminated.

Magnetic Effects of Electric Current

Electromagnetic Induction and its Applications

Electromagnetic Induction or Induction is a process in which a [conductor](#) is put in a particular position and magnetic field keeps varying or [magnetic field](#) is stationary and a conductor is moving. This produces a Voltage or EMF (Electromotive Force) across the electrical conductor. Michael Faraday discovered Law of Induction in 1830. Let us now study the Electromagnetic Induction in detail.

Electromagnetic induction

Suppose while shopping you go cashless and your parents use cards. The shopkeeper always scans or swipes the card. Shopkeeper does not take a photo of the card or tap it. Why does he swipe/scan it? And how does this swiping deduct money from the card? This happens because of the ‘**Electromagnetic Induction**’.

Can moving objects produce [electric currents](#)? How to determine a relationship between electricity and magnetism? Can you imagine the scenario if there were no computers, no telephones, no electric lights. The experiments of Faraday has led to the generation of generators and transformers.

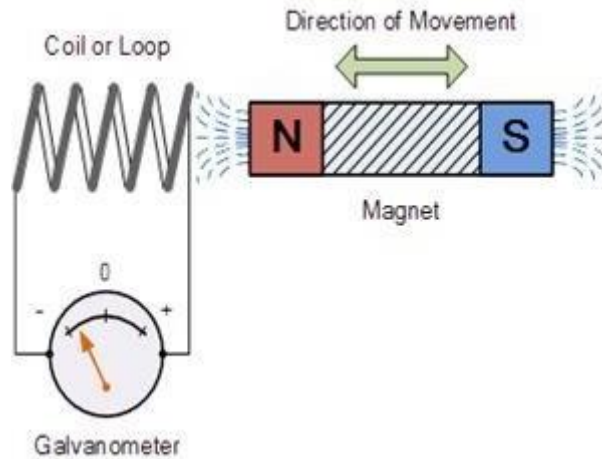

The induction of an electromotive force by the motion of a conductor across a magnetic field or by a change in magnetic flux in a magnetic field is called '**Electromagnetic Induction**'.

This either happens when a conductor is set in a moving magnetic field (when utilizing AC power source) or when a conductor is always moving in a stationary magnetic field.

This law of electromagnetic induction was found by **Michael Faraday**. He organized a leading wire according to the setup given underneath, connected to a gadget to gauge the voltage over the circuit. So when a bar magnet passes through the snaking, the voltage is measured in the circuit. The importance of this is a way of producing electrical energy in a circuit by using magnetic fields and not just batteries anymore. The machines like generators, transformers also the motors work on the principle of electromagnetic induction.

Faraday's law of Electromagnetic Induction

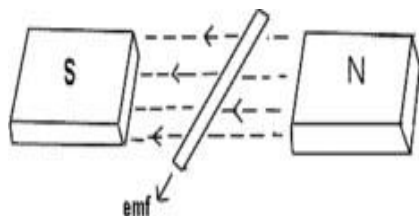

- First law: Whenever a conductor is placed in a varying magnetic field, EMF induces and this emf is called an induced emf and if the conductor is a closed circuit than the induced current flows through it.

- Second law: The magnitude of the induced EMF is equal to the rate of change of flux linkages.

Based on his experiments we now have Faraday's law of electromagnetic induction according to which the amount of voltage induced in a coil is proportional to the number of turns and the changing magnetic field of the coil.

So now, the induced voltage is as follows:

$$e = N \times d\Phi/dt$$

where,

e is the induced voltage

N is the number of turns in the coil

Φ is the magnetic flux

t is the time

Lenz's law of Electromagnetic Induction

Lenz law of electromagnetic induction states that, when an emf induces according to Faraday's law, the polarity (direction) of that induced emf is such that it opposes the cause of its production.

According to Lenz's law

$$E = -N (d\Phi/ dt) \text{ (volts)}$$

Eddy currents

By Lenz law of electromagnetic induction, the current swirls in such a way as to create a magnetic field opposing the change. Because of the tendency of eddy currents to oppose, eddy currents cause a loss of energy. Eddy currents transform more useful forms of energy, such as kinetic energy, into heat, which isn't generally useful. In many applications, the loss of useful energy is not particularly desirable, but there are some practical applications. Like:

- In the brakes of some trains. During braking, the brakes expose the metal wheels to a magnetic field which generates eddy currents in the wheels. The magnetic interaction between the applied field and the eddy currents slows the wheels down. The faster the wheels spin, the stronger is the effect, meaning that as the train slows the braking force is reduced, producing a smooth stopping motion.

- There are few galvanometers having a fixed core which are of nonmagnetic metallic material. When the coil oscillates, the eddy currents that generate in the core oppose the motion and bring the coil to rest.
- Induction furnace can be used to prepare alloys, by melting the metals. The eddy currents generated in the metals produce high temperature enough to melt it.

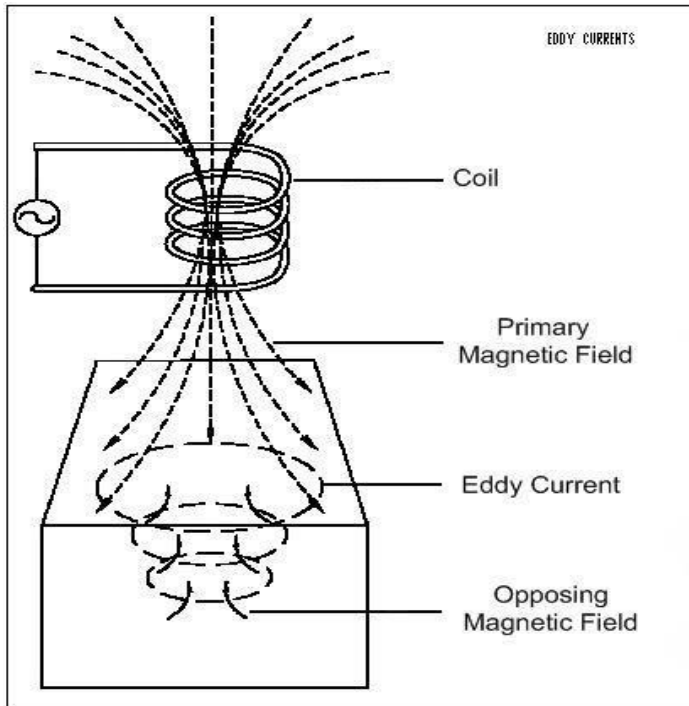

Applications of Electromagnetic Induction

1. Electromagnetic induction in AC generator
2. Electrical Transformers
3. [Magnetic Flow Meter](#)

Magnetic Effect of Electric Current

Part 1

Domestic Electric Circuit

Earth wire :- Safety measure to take care of leakages

Neutral wire :- } Supply electricity to circuits within home.
Live wire :- }

* Voltage and frequency are 220v and 50Hz respectively

Field

Surrounding region where force of magnet can be detected

- * Field strength depends on the closeness of the field lines
- * It is a **vector quantity**

Field Lines

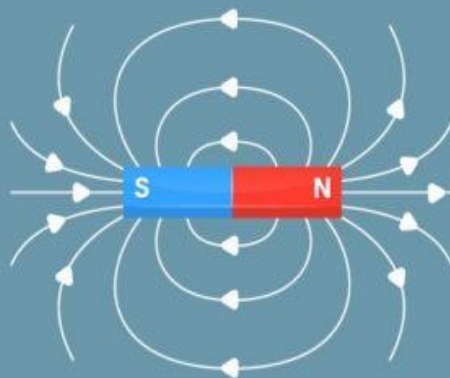

Field Lines

* Field strength \propto current

$$\propto \frac{1}{\text{Distance between magnet and conductor}}$$

Field due to current carrying conductor

SOLENOID

* Coil of many circular turns

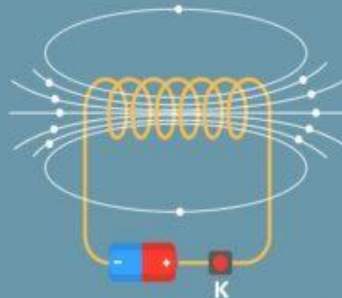

* Field is similar to that of a bar magnet

CIRCULAR LOOP

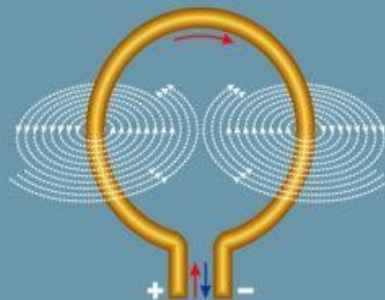

* If n loops - n times that for single loop

STRAIGHT CONDUCTOR

* Direction of the field

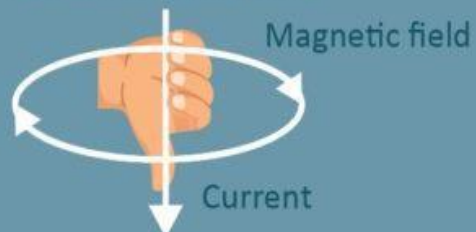

Magnetic Effect of Electric Current

Part 2

Force on current carrying conductor in Magnetic field

Direction of force - Fleming's Left hand rule

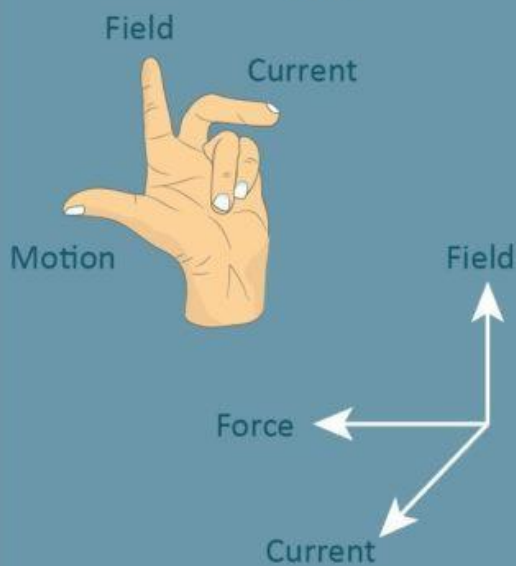

Electric Motor

- * Convert electrical energy into mechanical energy
- * As current passes through the coil in a magnetic field, force acting on the coil turns the coil.

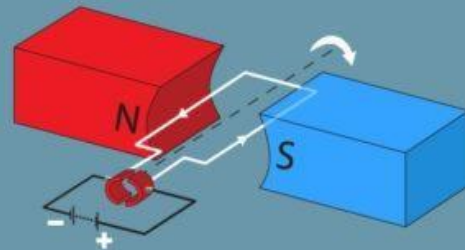

Electromagnetic Induction

- * Change in the magnetic field induces current.
- * Direction of current :- Fleming's right hand rule

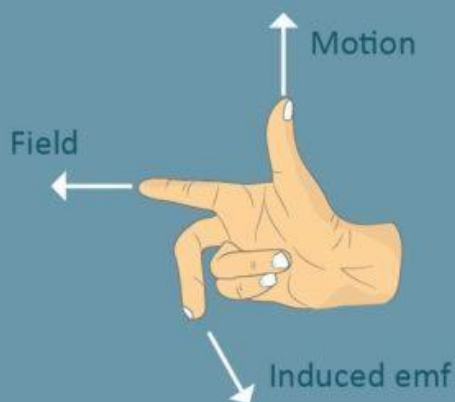

Electric Generator

- * Converts Mechanical energy into electrical energy.
- * Electrical current is produced because of rotation of coil inside the field.

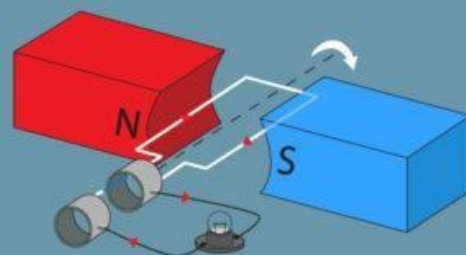

Electromagnetic induction in AC generator

One of the important application of electromagnetic induction is the generation of alternating current.

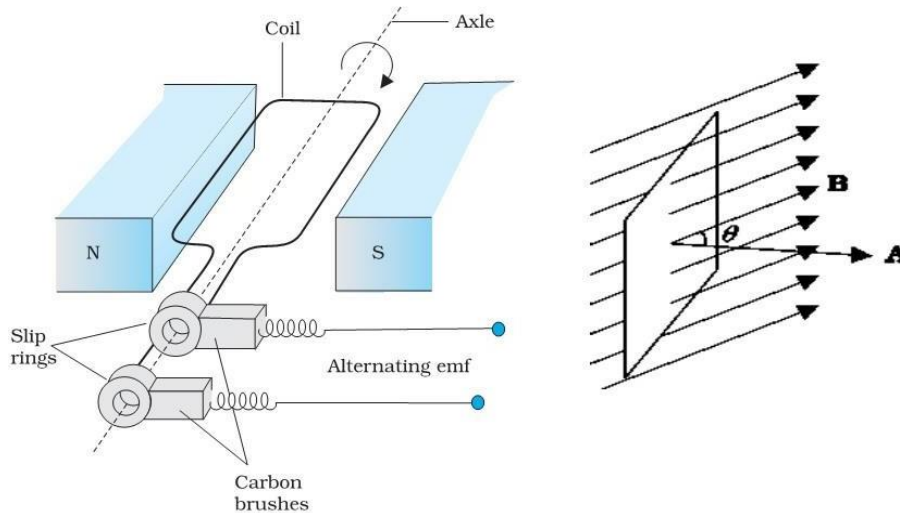

The AC generator with an output capacity of 100 MV is a more evolved machine. As the coil rotates in a magnetic field B , the effective area of the loop is $A \cos\theta$, where θ is the angle between A and B . This is a method of producing a flux change is the principle of operation of a simple ac generator. The axis of rotation coil is perpendicular to the direction of the magnetic field. The rotation of the coil causes the magnetic flux through it to change, so an emf keeps inducing in the coil.

Electrical Transformers

Another important application of electromagnetic induction is an electrical transformer. A transformer is a device that changes ac electric power at one voltage level to another level through the action of a magnetic field. A **step-down transformer** is the one in which the voltage is higher in the primary than the secondary voltage. Whereas the one in which the secondary voltage has more turns is a **step-up transformer**. Power companies use a step transformer to boost the voltage to 100 kV, that reduces the current and minimizes the loss of power in transmission lines. On the other end, household circuits use step-down transformers to decrease the voltage to the 120 or 240 V in them.

Example:-

Q. A straight wire length 0.20 m moves at a steady speed of 3.0 ms^{-1} at right angles to magnetic field of flux density 0.10 T. e.m.f induced across ends of wire is

1. 0.5 V
2. 0.06 V
3. 0.05 V
4. 0.04 V

Answer : 0.06 V

Cont...

5. AC Resistance and Impedance: -

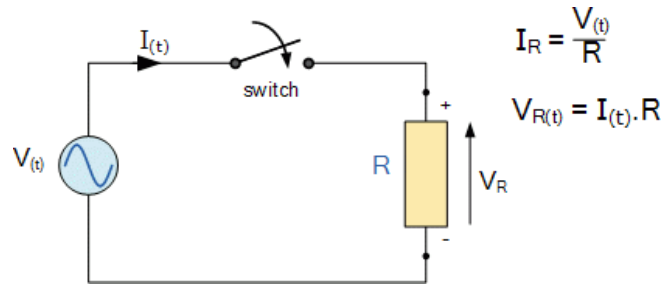

Impedance, measured in Ohms, is the effective resistance to current flow around an AC circuit containing resistances and reactances

We have seen in the previous tutorials that in an AC circuit containing sinusoidal waveforms, voltage and current phasors along with complex numbers can be used to represent a complex quantity.

We also saw that sinusoidal waveforms and functions that were previously drawn in the *time-domain* transform can be converted into the spatial or *phasor-domain* so that phasor diagrams can be constructed to find this phasor voltage-current relationship.

Now that we know how to represent a voltage or current as a phasor we can look at this relationship when applied to basic passive circuit elements such as an **AC Resistance** when connected to a single phase AC supply.

Any ideal basic circuit element such as a resistor can be described mathematically in terms of its voltage and current, and in the tutorial about *resistors*, we saw that the voltage across a pure ohmic resistor is linearly proportional to the current flowing through it as defined by Ohm's Law. Consider the circuit below.

AC Resistance with a Sinusoidal Supply

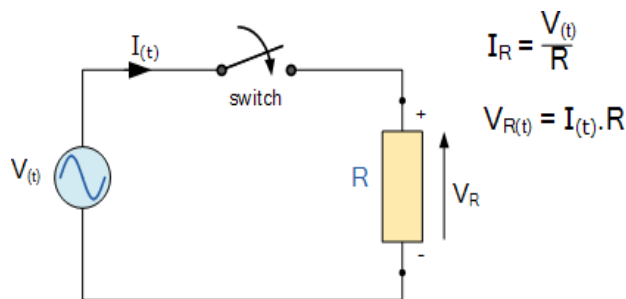

When the switch is closed, an AC voltage, V will be applied to resistor, R . This voltage will cause a current to flow which in turn will rise and fall as the applied voltage rises and falls sinusoidally. As the load is a resistance, the current and voltage will both reach their maximum or peak values and fall through zero at exactly the same time, i.e. they rise and fall simultaneously and are therefore said to be “in-phase”.

Then the electrical current that flows through an AC resistance varies sinusoidally with time and is represented by the expression, $I(t) = I_m \sin(\omega t + \theta)$, where I_m is the maximum amplitude of the current and θ is its phase angle. In addition we can also say that for any given current, i flowing through the resistor the maximum or peak voltage across the terminals of R will be given by Ohm’s Law as:

$$V_{(t)} = R.I_{(t)} = R.I_m \sin(\omega t + \theta)$$

and the instantaneous value of the current, i will be:

$$i_{R(t)} = I_{R(max)} \sin \omega t$$

So for a purely resistive circuit the alternating current flowing through the resistor varies in proportion to the applied voltage across it following the same sinusoidal pattern. As the supply frequency is common to both the voltage and current, their phasors will also be common resulting in the current being “in-phase” with the voltage, ($\theta = 0$).

In other words, there is no phase difference between the current and the voltage when using an AC resistance as the current will achieve its maximum, minimum and zero values whenever the voltage reaches its maximum, minimum and zero values as shown below.

Sinusoidal Waveforms for AC Resistance

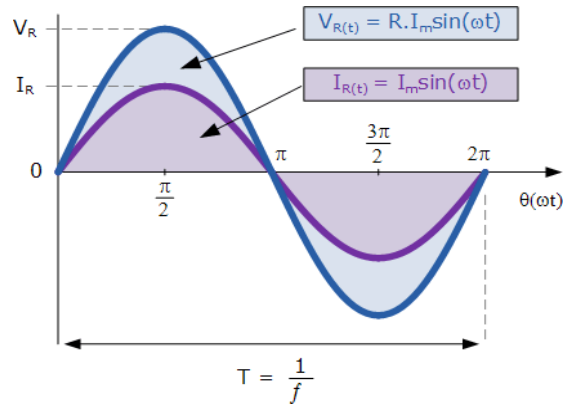

This “in-phase” effect can also be represented by a phasor diagram. In the complex domain, resistance is a real number only meaning that there is no “j” or imaginary component. Therefore, as the voltage and current are both in-phase with each other, there will be no phase difference ($\theta = 0$) between them, so the vectors of each quantity are drawn super-imposed upon one another along the same reference axis. The transformation from the sinusoidal time-domain into the phasor-domain is given as.

Phasor Diagram for AC Resistance

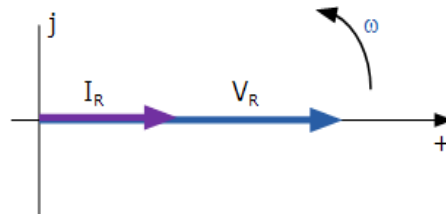

As a phasor represents the RMS values of the voltage and current quantities unlike a vector which represents the peak or maximum values, dividing the peak value of the time-domain expressions above by $\sqrt{2}$ the corresponding voltage-current phasor relationship is given as.

RMS Relationship

$$I = \frac{I_m}{\sqrt{2}} \angle \theta \text{ A} \quad \text{and} \quad V = \frac{R \cdot I_m}{\sqrt{2}} \angle \theta \text{ V}$$

$$\therefore R = \frac{V}{I} = \frac{(R \cdot I_m / \sqrt{2}) \angle \theta}{(I_m / \sqrt{2}) \angle \theta}$$

Phase Relationship

$$V = R \cdot I_{\text{RMS}} \angle \theta \quad \text{and} \quad I = I_{\text{RMS}} \angle \theta$$

$$V \angle \theta_v = I \angle \theta_i$$

$$\therefore \theta_v = \theta_i \text{ (in-phase)}$$

]

This shows that a pure resistance within an AC circuit produces a relationship between its voltage and current phasors in exactly the same way as it would relate the same resistors voltage and current

relationship within a DC circuit. However, in a DC circuit this relationship is commonly called **Resistance**, as defined by Ohm's Law but in a sinusoidal AC circuit this voltage-current relationship is now called **Impedance**. In other words, in an AC circuit electrical resistance is called "Impedance".

In both cases this voltage-current (V-I) relationship is always linear in a pure resistance. So when using resistors in AC circuits the term **Impedance**, symbol **Z** is the generally used to mean its resistance. Therefore, we can correctly say that for a resistor, DC resistance = AC impedance , or $R = Z$.

The impedance vector is represented by the letter, (Z) for an AC resistance value with the units of Ohm's (Ω) the same as for DC. Then Impedance (or AC resistance) can be defined as:

AC Impedance

$$Z = \frac{V}{I} \Omega's$$

Impedance can also be represented by a complex number as it depends upon the frequency of the circuit, ω when reactive components are present. But in the case of a purely resistive circuit this reactive component will always be zero and the general expression for impedance in a purely resistive circuit given as a complex number will be:

$$Z = R + j0 = R \Omega's$$

Since the phase angle between the voltage and current in a purely resistive AC circuit is zero, the power factor must also be zero and is given as: $\cos 0^\circ = 1.0$, Then the instantaneous power consumed in the resistor is given by:

$$P = V.I = V_m \sin \omega t \times I_m \sin \omega t = V_m I_m \sin^2 \omega t$$

$$\therefore P_{\max} = \sin^2 (\omega t), \quad \text{where } P_{\max} = V_{\max} I_{\max}$$

However, as the average power in a resistive or reactive circuit depends upon the phase angle and in a purely resistive circuit this is equal to $\theta = 0$, the power factor is equal to one so the average power consumed by an AC resistance can be defined simply by using Ohm's Law as:

$$P = V.I = I^2 R = \frac{V^2}{R} \text{ watts}$$

which are the same Ohm's Law equations as for DC circuits. Then the effective power consumed by an AC resistance is equal to the power consumed by the same resistor in a DC circuit.

Many AC circuits such as heating elements and lamps consist of a pure ohmic resistance only and have negligible values of inductance or capacitance containing on impedance.

In such circuits we can use both [Ohm's Law](#) , [Kirchoff's Law](#) as well as simple circuit rules for calculating and finding the voltage, current, impedance and power as in DC circuit analysis. When working with such rules it is usual to use RMS values only.

AC Resistance Example No1

An electrical heating element which has an AC resistance of 60 Ohms is connected across a 240V AC single phase supply. Calculate the current drawn from the supply and the power consumed by the heating element. Also draw the corresponding phasor diagram showing the phase relationship between the current and voltage.

1. The supply current:

$$I = \frac{V}{R} = \frac{240}{60} = 4.0 \text{ A}$$

2. The Active power consumed by the AC resistance is calculated as:

$$P = I^2R = 4^2 \cdot 60 = 960 \text{ W}$$

3. As there is no phase difference in a resistive component, ($\theta = 0$), the corresponding phasor diagram is given as:

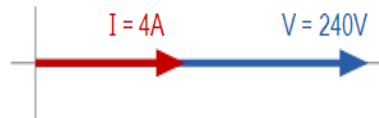

AC Resistance Example No2

A sinusoidal voltage supply defined as: $V(t) = 100 \times \cos(\omega t + 30^\circ)$ is connected to a pure resistance of 50 Ohms. Determine its impedance and the peak value of the current flowing through the circuit. Draw the corresponding phasor diagram.

The sinusoidal voltage across the resistance will be the same as for the supply in a purely resistive circuit. Converting this voltage from the time-domain expression into the phasor-domain expression gives us:

$$V_{R(t)} = 100\cos(\omega t + 30^\circ) \Rightarrow V_R = 100\angle 30^\circ \text{ volts}$$

Applying Ohms Law gives us:

$$I_R = \frac{V_R}{R} = \frac{100\angle 30^\circ}{50\Omega} = 2\angle 30^\circ \text{ Amps}$$

The corresponding phasor diagram will therefore be:

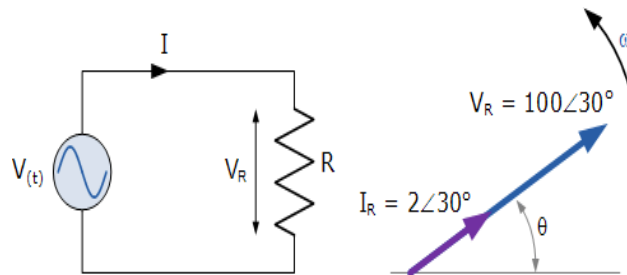

Impedance Summary

In a pure ohmic **AC Resistance**, the current and voltage are both “in-phase” as there is no phase difference between them. The current flowing through the resistance is directly proportional to the voltage across it with this linear relationship in an AC circuit being called **Impedance**.

Impedance, which is given the letter Z, in a pure ohmic resistance is a complex number consisting only of a real part being the actual AC resistance value, (R) and a zero imaginary part, (j0). Because of this Ohm’s Law can be used in circuits containing an AC resistance to calculate these voltages and currents.

In the next tutorial about AC Inductance we will look at the voltage-current relationship of an inductor when a steady state sinusoidal AC waveform is applied to it along with its phasor diagram representation for both pure and non-pure inductance’s.

6. AC Inductance and Inductive Reactance: -

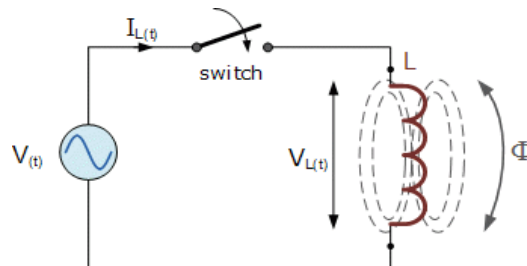

The opposition to current flow through an AC Inductor is called Inductive Reactance and which depends lineally on the supply frequency

Inductors and chokes are basically coils or loops of wire that are either wound around a hollow tube former (air cored) or wound around some ferromagnetic material (iron cored) to increase their inductive value called **inductance**.

Inductors store their energy in the form of a magnetic field that is created when a voltage is applied across the terminals of an inductor. The growth of the current flowing through the inductor is not instant but is determined by the inductors own self-induced or back emf value. Then for an inductor coil, this back emf voltage V_L is proportional to the *rate of change of the current* flowing through it.

This current will continue to rise until it reaches its maximum steady state condition which is around five time constants when this self-induced back emf has decayed to zero. At this point a steady state current is flowing through the coil, no more back emf is induced to oppose the current flow and therefore, the coil acts more like a short circuit allowing maximum current to flow through it.

However, in an alternating current circuit which contains an **AC Inductance**, the flow of current through an inductor behaves very differently to that of a steady state DC voltage. Now in an AC circuit, the opposition to the current flowing through the coils windings not only depends upon the inductance of the coil but also the frequency of the applied voltage waveform as it varies from its positive to negative values.

The actual opposition to the current flowing through a coil in an AC circuit is determined by the AC Resistance of the coil with this AC resistance being represented by a complex number. But to distinguish a DC resistance value from an AC resistance value, which is also known as Impedance, the term **Reactance** is used.

Like resistance, reactance is measured in Ohm's but is given the symbol "X" to distinguish it from a purely resistive "R" value and as the component in question is an inductor, the reactance of an inductor is called **Inductive Reactance**, (X_L) and is measured in Ohms. Its value can be found from the formula.

Inductive Reactance

$$X_L = 2\pi fL$$

- Where:
- X_L = Inductive Reactance in Ohms, (Ω)
- π (pi) = a numeric constant of 3.142
- f = Frequency in Hertz, (Hz)
- L = Inductance in Henries, (H)

We can also define inductive reactance in radians, where Omega, ω equals $2\pi f$.

$$X_L = \omega L$$

So whenever a sinusoidal voltage is applied to an inductive coil, the back emf opposes the rise and fall of the current flowing through the coil and in a purely inductive coil which has zero resistance or losses, this impedance (which can be a complex number) is equal to its inductive reactance. Also reactance is represented by a vector as it has both a magnitude and a direction (angle). Consider the circuit below.

AC Inductance with a Sinusoidal Supply

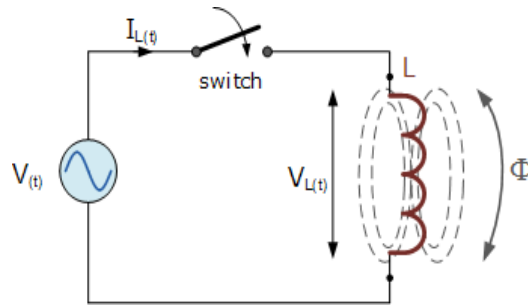

This simple circuit above consists of a pure inductance of L Henrys (H), connected across a sinusoidal voltage given by the expression: $V(t) = V_{\max} \sin \omega t$. When the switch is closed this sinusoidal voltage will cause a current to flow and rise from zero to its maximum value. This rise or change in the current will induce a magnetic field within the coil which in turn will oppose or restrict this change in the current.

But before the current has had time to reach its maximum value as it would in a DC circuit, the voltage changes polarity causing the current to change direction. This change in the other direction once again being delayed by the self-induced back emf in the coil, and in a circuit containing a pure inductance only, the current is delayed by 90° .

The applied voltage reaches its maximum positive value a quarter ($1/4f$) of a cycle earlier than the current reaches its maximum positive value, in other words, a voltage applied to a purely inductive circuit "LEADS" the current by a quarter of a cycle or 90° as shown below.

Sinusoidal Waveforms for AC Inductance

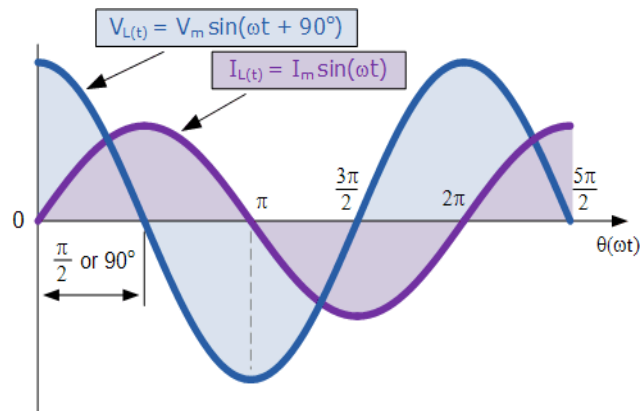

This effect can also be represented by a phasor diagram were in a purely inductive circuit the voltage "LEADS" the current by 90° . But by using the voltage as our reference, we can also say that the current "LAGS" the voltage by one quarter of a cycle or 90° as shown in the vector diagram below.

Phasor Diagram for AC Inductance

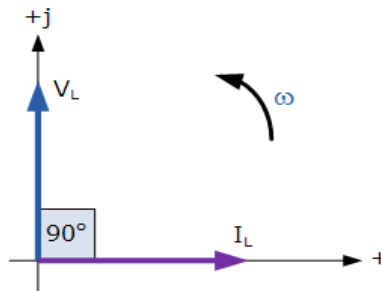

So for a pure loss less inductor, V_L “leads” I_L by 90° , or we can say that I_L “lags” V_L by 90° .

There are many different ways to remember the phase relationship between the voltage and current flowing through a pure inductor circuit, but one very simple and easy to remember way is to use the mnemonic expression “ELI” (pronounced *Ellie* as in the girls name). ELI stands for Electromotive force first in an AC inductance, L before the current I. In other words, voltage before the current in an inductor, E, L, I equals “ELI”, and whichever phase angle the voltage starts at, this expression always holds true for a pure inductor circuit.

The Effect of Frequency on Inductive Reactance

When a 50Hz supply is connected across a suitable AC Inductance, the current will be delayed by 90° as described previously and will obtain a peak value of I amps before the voltage reverses polarity at the end of each half cycle, i.e. the current rises up to its maximum value in “T secs”.

If we now apply a 100Hz supply of the same peak voltage to the coil, the current will still be delayed by 90° but its maximum value will be lower than the 50Hz value because the time it requires to reach its maximum value has been reduced due to the increase in frequency because now it only has “1/2 T secs” to reach its peak value. Also, the rate of change of the flux within the coil has also increased due to the increase in frequency.

Then from the above equation for inductive reactance, it can be seen that if either the **Frequency** OR the **Inductance** is increased the overall inductive reactance value of the coil would also increase. As the frequency increases and approaches infinity, the inductors reactance and therefore its impedance would also increase towards infinity acting like an open circuit.

Likewise, as the frequency approaches zero or DC, the inductors reactance would also decrease to zero, acting like a short circuit. This means then that inductive reactance is “directly proportional to frequency” and has a small value at low frequencies and a high value at higher frequencies as shown.

Inductive Reactance against Frequency

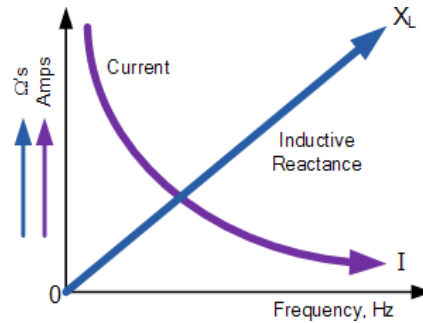

The inductive reactance of an inductor increases as the frequency across it increases therefore inductive reactance is proportional to frequency ($X_L \propto f$) as the back emf generated in the inductor is equal to its inductance multiplied by the rate of change of current in the inductor.

Also, as the frequency increases the current flowing through the inductor also reduces in value.

We can present the effect of very low and very high frequencies on the reactance of a pure AC Inductance as follows:

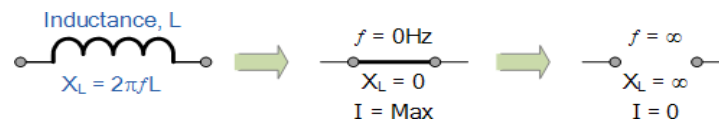

In an AC circuit containing pure inductance the following formula applies:

$$\text{Current, } I = \frac{\text{Voltage}}{\text{Opposition to current flow}} = \frac{V}{X_L}$$

So how did we arrive at this equation. Well, the self-induced emf in the inductor is determined by Faraday's Law that produces the effect of self-induction in the inductor due to the rate of change of the current and the maximum value of the induced emf will correspond to the maximum rate of change. Then the voltage in the inductor coil is given as:

$$V_{L(t)} = L \frac{di_{L(t)}}{dt}$$

If, $i_{L(t)} = I_{\max} \sin(\omega t)$ then:

$$\begin{aligned} V_{L(t)} &= L \frac{d}{dt} I_{\max} \sin(\omega t + \theta) \\ &= \omega L I_{\max} \cos(\omega t + \theta) \end{aligned}$$

then the voltage across an AC inductance will be defined as:

$$V_L = \omega L I_{\max} \sin(\omega t + 90^\circ)$$

Where: $V_L = I\omega L$ which is the voltage amplitude and $\theta = +90^\circ$ which is the phase difference or phase angle between the voltage and current.

In the Phasor Domain

In the phasor domain the voltage across the coil is given as:

$$V_L = j\omega L I$$

where: $j\omega L = jX_L = 2\pi fL = \text{IMPEDANCE, } Z$

and in **Polar Form** this would be written as: $X_L \angle 90^\circ$ where:

$X_L \angle \theta = \frac{V_L \angle +90^\circ}{I_L \angle 0^\circ}$	
---	--

$$X_L \angle \theta = j\omega L = 0 + jX_L = \omega L \angle +90^\circ = Z \angle +90^\circ$$

AC through a Series R + L Circuit

We have seen above that the current flowing through a purely inductive coil lags the voltage by 90° and when we say a purely inductive coil we mean one that has no ohmic resistance and therefore, no I^2R losses. But in the real world, it is impossible to have a purely **AC Inductance** only.

All electrical coils, relays, solenoids and transformers will have a certain amount of resistance no matter how small associated with the coil turns of wire being used. This is because copper wire has resistivity. Then we can consider our inductive coil as being one that has a resistance, R in series with an inductance, L producing what can be loosely called an “impure inductance”.

If the coil has some “internal” resistance then we need to represent the total impedance of the coil as a resistance in series with an inductance and in an AC circuit that contains both inductance, L and resistance, R the voltage, V across the combination will be the phasor sum of the two component voltages, V_R and V_L .

This means then that the current flowing through the coil will still lag the voltage, but by an amount less than 90° depending upon the values of V_R and V_L , the phasor sum. The new angle between the voltage and the current waveforms gives us their phase difference which as we know is the phase angle of the circuit given the Greek symbol phi, Φ .

Consider the circuit below were a pure non-inductive resistance, R is connected in series with a pure inductance, L.

Series Resistance-Inductance Circuit

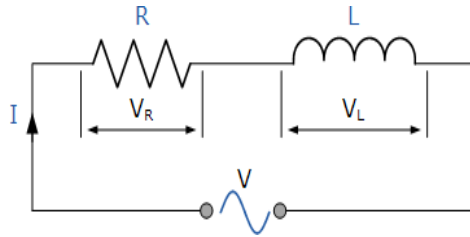

In the RL series circuit above, we can see that the current is common to both the resistance and the inductance while the voltage is made up of the two component voltages, V_R and V_L . The resulting voltage of these two components can be found either mathematically or by drawing a vector diagram. To be able to produce the vector diagram a reference or common component must be found and in a series AC circuit the current is the reference source as the same current flows through the resistance and the inductance. The individual vector diagrams for a pure resistance and a pure inductance are given as:

Vector Diagrams for the Two Pure Components

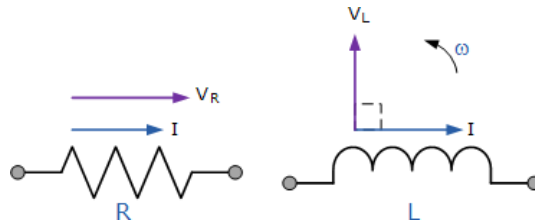

We can see from above and from our previous tutorial about AC Resistance that the voltage and current in a resistive circuit are both in phase and therefore vector V_R is drawn superimposed to scale onto the current vector. Also from above it is known that the current lags the voltage in an AC inductance (pure) circuit therefore vector V_L is drawn 90° in front of the current and to the same scale as V_R as shown.

Vector Diagram of the Resultant Voltage

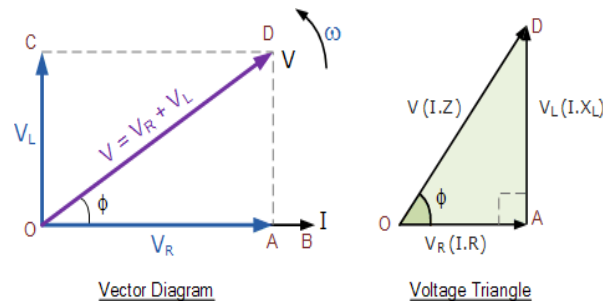

From the vector diagram above, we can see that line OB is the horizontal current reference and line OA is the voltage across the resistive component which is in-phase with the current. Line OC shows the inductive voltage which is 90° in front of the current therefore it can still be seen that the current lags the purely inductive voltage by 90°. Line OD gives us the resulting supply voltage. Then:

- V equals the r.m.s value of the applied voltage.
- I equals the r.m.s. value of the series current.
- V_R equals the I.R voltage drop across the resistance which is in-phase with the current.
- V_L equals the I.X_L voltage drop across the inductance which leads the current by 90°.

As the current lags the voltage in a pure inductance by exactly 90° the resultant phasor diagram drawn from the individual voltage drops V_R and V_L represents a right-angled voltage triangle shown above as OAD. Then we can also use Pythagoras theorem to mathematically find the value of this resultant voltage across the resistor/inductor (RL) circuit.

As V_R = I.R and V_L = I.X_L the applied voltage will be the vector sum of the two as follows:

$$V^2 = V_R^2 + V_L^2$$

$$V = \sqrt{V_R^2 + V_L^2}$$

$$V = \sqrt{(I.R)^2 + (I.X_L)^2}$$

$$\therefore I = \frac{V}{\sqrt{R^2 + X_L^2}}$$

The quantity $\sqrt{R^2 + X_L^2}$ represents the **impedance**, Z of the circuit.

The Impedance of an AC Inductance

Impedance, Z is the “TOTAL” opposition to current flowing in an AC circuit that contains both Resistance, (the real part) and Reactance (the imaginary part). Impedance also has the units of Ohms, Ω.

Impedance depends upon the frequency, ω of the circuit as this affects the circuits reactive components and in a series circuit all the resistive and reactive impedance's add together.

Impedance can also be represented by a complex number, $Z = R + jX_L$ but it is not a phasor, it is the result of two or more phasors combined together. If we divide the sides of the voltage triangle above by I , another triangle is obtained whose sides represent the resistance, reactance and impedance of the circuit as shown below.

The RL Impedance Triangle

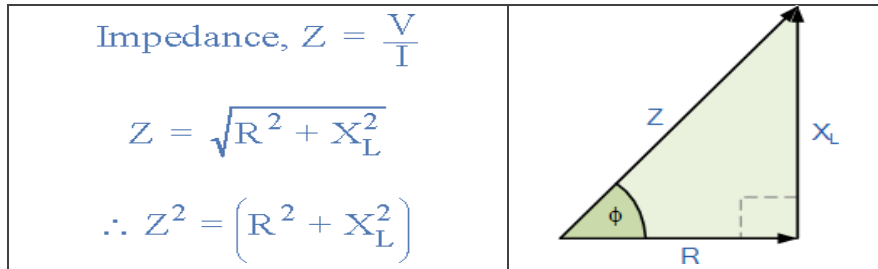

Then: (Impedance)² = (Resistance)² + (j Reactance)² where j represents the 90° phase shift.

This means that the positive phase angle, θ between the voltage and current is given as.

Phase Angle

$$Z^2 = R^2 + X_L^2$$

$$\cos^{-1} \phi = \frac{R}{Z}$$

$$\sin^{-1} \phi = \frac{X_L}{Z}$$

$$\tan^{-1} \phi = \frac{X_L}{R}$$

While our example above represents a simple non-pure AC inductance, if two or more inductive coils are connected together in series or a single coil is connected in series with many non-inductive resistances, then the total resistance for the resistive elements would be equal to: $R_1 + R_2 + R_3$ etc, giving a total resistive value for the circuit.

Likewise, the total reactance for the inductive elements would be equal to: $X_1 + X_2 + X_3$ etc, giving a total reactance value for the circuit. This way a circuit containing many chokes, coils and resistors can be easily reduced down to an impedance value, Z comprising of a single resistance in series with a single reactance, $Z^2 = R^2 + X^2$.

AC Inductance Example No1

In the following circuit, the supply voltage is defined as: $V(t) = 325 \sin(314t - 30^\circ)$ and $L = 2.2\text{H}$. Determine the value of the rms current flowing through the coil and draw the resulting phasor diagram.

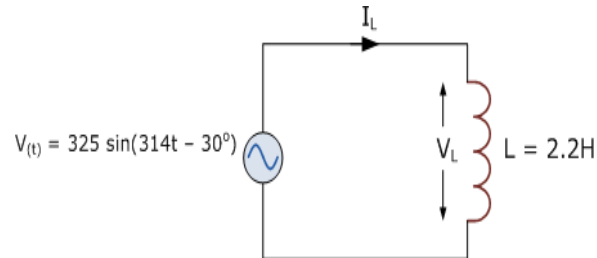

The rms voltage across the coil will be the same as from the supply voltage. If the power supplies peak voltage is 325V, then the equivalent rms value will be 230V. Converting this time domain value into its polar form gives us: $V_L = 230 \angle -30^\circ$ (volts). The inductive reactance of the coil is: $X_L = \omega L = 314 \times 2.2 = 690\Omega$. Then the current flowing through the coil can be found using Ohms law as:

$$I_L = \frac{V_L}{jX_L} = \frac{230 \angle -30^\circ}{690 \angle 90^\circ} = 0.33 \angle -120^\circ \text{ (A)}$$

With the current lagging the voltage by 90° the phasor diagram will be.

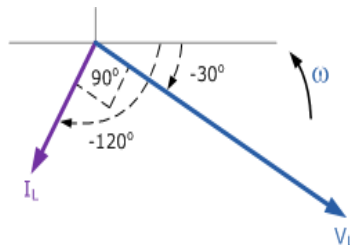

AC Inductance Example No2

A coil has a resistance of 30Ω and an inductance of 0.5H . If the current flowing through the coil is 4amps. What will be the rms value of the supply voltage if its frequency is 50Hz.

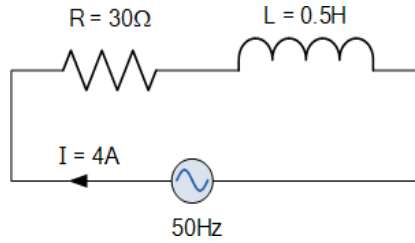

The impedance of the circuit will be:

$$X_L = 2\pi fL = 2\pi \times 50 \times 0.5 = 157\Omega$$

$$Z = \sqrt{R^2 + X_L^2}$$

$$Z = \sqrt{30^2 + 157^2}$$

$$Z = 159.8\Omega$$

Then the voltage drops across each component is calculated as:

$$V_S = IZ = 4 \times 159.8 = 640\text{v}$$

$$V_R = IR = 4 \times 30 = 120\text{v}$$

$$V_L = I X_L = 4 \times 157 = 628\text{v}$$

The phase angle between the current and supply voltage is calculated as:

$$\tan^{-1} \phi = \frac{X_L}{R} = \frac{157}{30} = 79.2^\circ$$

The phasor diagram will be.

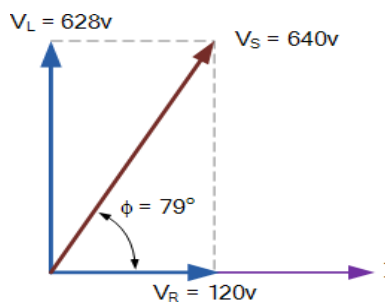

7. AC Capacitance and Capacitive Reactance:-

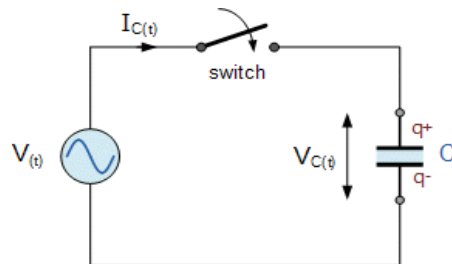

The opposition to current flow through an AC Capacitor is called Capacitive Reactance and which itself is inversely proportional to the supply frequency

Capacitors store energy on their conductive plates in the form of an electrical charge. When a capacitor is connected across a DC supply voltage it charges up to the value of the applied voltage at a rate determined by its time constant.

A capacitor will maintain or hold this charge indefinitely as long as the supply voltage is present. During this charging process, a charging current, i flows into the capacitor opposed by any changes to the voltage at a rate which is equal to the rate of change of the electrical charge on the plates. A capacitor therefore has an opposition to current flowing onto its plates.

The relationship between this charging current and the rate at which the capacitors supply voltage changes can be defined mathematically as: $i = C(dv/dt)$, where C is the capacitance value of the capacitor in farads and dv/dt is the rate of change of the supply voltage with respect to time. Once it is “fully-charged” the capacitor blocks the flow of any more electrons onto its plates as they have become saturated and the capacitor now acts like a temporary storage device.

A pure capacitor will maintain this charge indefinitely on its plates even if the DC supply voltage is removed. However, in a sinusoidal voltage circuit which contains “AC Capacitance”, the capacitor will alternately charge and discharge at a rate determined by the frequency of the supply. Then capacitors in AC circuits are constantly charging and discharging respectively.

When an alternating sinusoidal voltage is applied to the plates of an AC capacitor, the capacitor is charged firstly in one direction and then in the opposite direction changing polarity at the same rate as the AC supply voltage. This instantaneous change in voltage across the capacitor is opposed by the fact that it takes a certain amount of time to deposit (or release) this charge onto the plates and is given by $V = Q/C$. Consider the circuit below.

AC Capacitance with a Sinusoidal Supply

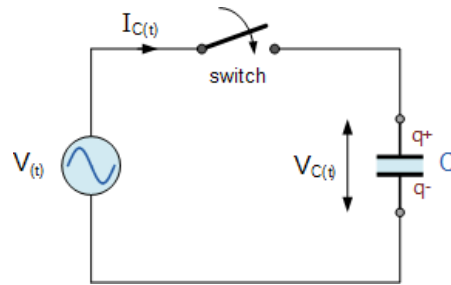

When the switch is closed in the circuit above, a high current will start to flow into the capacitor as there is no charge on the plates at $t = 0$. The sinusoidal supply voltage, V is increasing in a positive direction at its maximum rate as it crosses the zero-reference axis at an instant in time given as 0° . Since the rate of change of the potential difference across the plates is now at its maximum value, the flow of current into the capacitor will also be at its maximum rate as the maximum number of electrons are moving from one plate to the other.

As the sinusoidal supply voltage reaches its 90° point on the waveform it begins to slow down and for a very brief instant in time the potential difference across the plates is neither increasing nor decreasing therefore the current decreases to zero as there is no rate of voltage change. At this 90° point the potential difference across the capacitor is at its maximum (V_{max}), no current flows into the capacitor as the capacitor is now fully charged and its plates saturated with electrons.

At the end of this instant in time the supply voltage begins to decrease in a negative direction down towards the zero-reference line at 180° . Although the supply voltage is still positive in nature the capacitor starts to discharge some of its excess electrons on its plates in an effort to maintain a constant voltage. This results in the capacitor current flowing in the opposite or negative direction.

When the supply voltage waveform crosses the zero-reference axis point at instant 180° the rate of change or slope of the sinusoidal supply voltage is at its maximum but in a negative direction, consequently the current flowing into the capacitor is also at its maximum rate at that instant. Also, at this 180° point the potential difference across the plates is zero as the amount of charge is equally distributed between the two plates.

Then during this first half cycle 0° to 180° the applied voltage reaches its maximum positive value a quarter ($1/4f$) of a cycle after the current reaches its maximum positive value, in other words, a voltage applied to a purely capacitive circuit "LAGS" the current by a quarter of a cycle or 90° as shown below.

Sinusoidal Waveforms for AC Capacitance

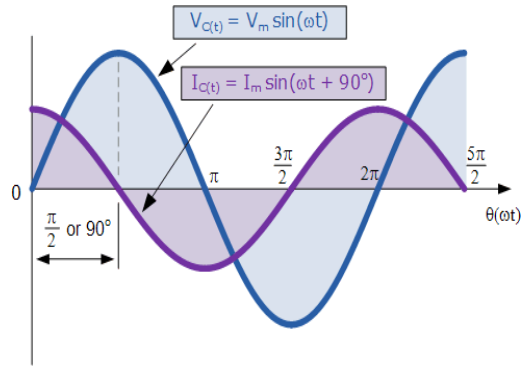

During the second half cycle 180° to 360° , the supply voltage reverses direction and heads towards its negative peak value at 270° . At this point the potential difference across the plates is neither decreasing nor increasing and the current decreases to zero. The potential difference across the capacitor is at its maximum negative value, no current flows into the capacitor and it becomes fully charged the same as at its 90° point but in the opposite direction.

As the negative supply voltage begins to increase in a positive direction towards the 360° point on the zero-reference line, the fully charged capacitor must now lose some of its excess electrons to maintain a constant voltage as before and starts to discharge itself until the supply voltage reaches zero at 360° at which the process of charging and discharging starts over again.

From the voltage and current waveforms and description above, we can see that the current is always leading the voltage by $1/4$ of a cycle or $\pi/2 = 90^\circ$ "out-of-phase" with the potential difference across the capacitor because of this charging and discharging process. Then the phase relationship between the voltage and current in an AC capacitance circuit is the exact opposite to that of an [AC Inductance](#).

This effect can also be represented by a phasor diagram where in a purely capacitive circuit the voltage "LAGS" the current by 90° . But by using the voltage as our reference, we can also say that the current "LEADS" the voltage by one quarter of a cycle or 90° as shown in the vector diagram below.

Phasor Diagram for AC Capacitance

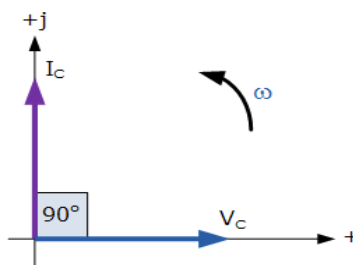

So, for a pure capacitor, V_C "lags" I_C by 90° , or we can say that I_C "leads" V_C by 90° .

There are many different ways to remember the phase relationship between the voltage and current flowing in a pure AC capacitance circuit, but one very simple and easy to remember way is to use the mnemonic expression called "ICE". ICE stands for current I first in an AC capacitance, C before Electromotive force. In other words, current before the voltage in a capacitor, I, C, E equals "ICE", and whichever phase angle the voltage starts at, this expression always holds true for a pure AC capacitance circuit.

Capacitive Reactance

So we now know that capacitors oppose changes in voltage with the flow of electrons onto the plates of the capacitor being directly proportional to the rate of voltage change across its plates as the capacitor charges and discharges. Unlike a resistor where the opposition to current flow is its actual resistance, the opposition to current flow in a capacitor is called **Reactance**.

Like resistance, reactance is measured in Ohm's but is given the symbol X to distinguish it from a purely resistive R value and as the component in question is a capacitor, the reactance of a capacitor is called **Capacitive Reactance**, (X_C) which is measured in Ohms.

Since capacitors charge and discharge in proportion to the rate of voltage change across them, the faster the voltage changes the more current will flow. Likewise, the slower the voltage changes the less current will flow. This means then that the reactance of an AC capacitor is "inversely proportional" to the frequency of the supply as shown.

Capacitive Reactance

$$X_C = \frac{1}{2\pi fC}$$

Where: X_C is the Capacitive Reactance in Ohms, f is the frequency in Hertz and C is the AC capacitance in Farads, symbol F.

When dealing with AC capacitance, we can also define capacitive reactance in terms of radians, where Omega, ω equals $2\pi f$.

$$X_C = \frac{1}{\omega C}$$

From the above formula we can see that the value of capacitive reactance and therefore its overall impedance (in Ohms) decreases towards zero as the frequency increases acting like a short circuit. Likewise, as the frequency approaches zero or DC, the capacitors reactance increases to infinity, acting like an open circuit which is why capacitors block DC.

The relationship between capacitive reactance and frequency is the exact opposite to that of inductive reactance, (X_L) we saw in the previous tutorial. This means then that capacitive reactance is "inversely proportional to frequency" and has a high value at low frequencies and a low value at higher frequencies as shown.

Capacitive Reactance against Frequency

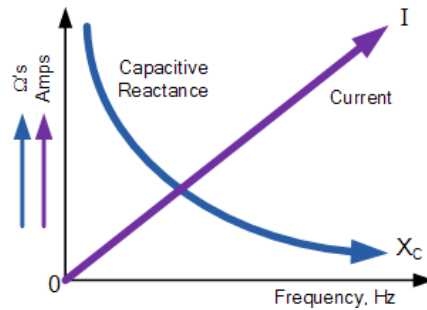

Capacitive reactance of a capacitor decreases as the frequency across its plates increases. Therefore, capacitive reactance is inversely proportional to frequency. Capacitive reactance opposes current flow but the electrostatic charge on the plates (its AC capacitance value) remains constant.

This means it becomes easier for the capacitor to fully absorb the change in charge on its plates during each half cycle. Also as the frequency increases the current flowing into the capacitor increases in value because the rate of voltage change across its plates increases.

We can present the effect of very low and very high frequencies on the reactance of a pure AC Capacitance as follows:

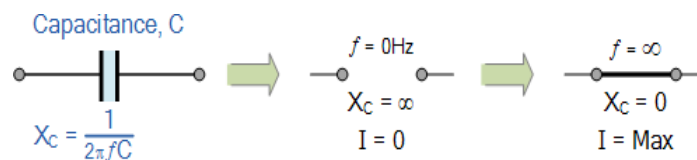

In an AC circuit containing pure capacitance the current (electron flow) flowing into the capacitor is given as:

$$I_{C(t)} = \frac{dq}{dt} \quad \text{where: } q = CV_C = CV_{\max} \sin(\omega t)$$

$$\therefore I_{C(t)} = \frac{d}{dt} CV_{\max} \sin(\omega t) = \omega CV_{\max} \cos(\omega t)$$

$$\text{If: } I_{\max} = \frac{V_{\max}}{X_C} \quad \text{where: } X_C = \frac{1}{2\pi fC} = \frac{1}{\omega C}$$

$$\text{then: } I_{\max} = \omega CV_{\max}$$

and therefore, the rms current flowing into an AC capacitance will be defined as:

$$I_{C(t)} = I_{\max} \sin(\omega t + 90^\circ)$$

Where: $I_C = V/(1/\omega C)$ (or $I_C = V/X_C$) is the current magnitude and $\theta = +90^\circ$ which is the phase difference or phase angle between the voltage and current. For a purely capacitive circuit, I_C leads V_C by 90° , or V_C lags I_C by 90° .

Phasor Domain

In the phasor domain the voltage across the plates of an AC capacitance will be:

$$V_C = \frac{1}{j\omega C} \times I_C$$

$$\text{where: } \frac{1}{j\omega C} = jX_C = \frac{1}{2\pi fC} = \text{IMPEDANCE, } Z$$

and in **Polar Form** this would be written as: $X_C \angle -90^\circ$ where:

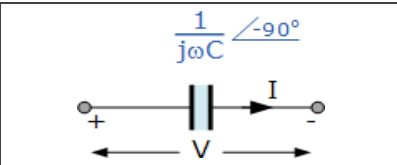
$X_C \angle \theta = \frac{V_C \angle 0^\circ}{I_C \angle +90^\circ}$	
---	--

$$X_C \angle \theta = \frac{1}{j\omega C} = 0 - jX_C = \frac{1}{\omega C} \angle -90^\circ = Z \angle -90^\circ$$

AC Across a Series R + C Circuit

We have seen from above that the current flowing into a pure AC capacitance leads the voltage by 90° . But in the real world, it is impossible to have a pure **AC Capacitance** as all capacitors will have a certain amount of internal resistance across their plates giving rise to a leakage current.

Then we can consider our capacitor as being one that has a resistance, R in series with a capacitance, C producing what can be loosely called an “impure capacitor”.

If the capacitor has some “internal” resistance then we need to represent the total impedance of the capacitor as a resistance in series with a capacitance and in an AC circuit that contains both capacitance, C and resistance, R the voltage phasor, V across the combination will be equal to the phasor sum of the two component voltages, V_R and V_C .

This means then that the current flowing into the capacitor will still lead the voltage, but by an amount less than 90° depending upon the values of R and C giving us a phasor sum with the corresponding phase angle between them given by the Greek symbol phi, Φ .

Consider the series RC circuit below where an ohmic resistance, R is connected in series with a pure capacitance, C .

Series Resistance-Capacitance Circuit

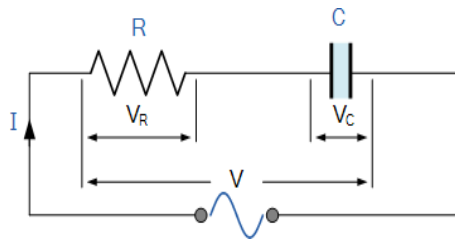

In the RC series circuit above, we can see that the current flowing into the circuit is common to both the resistance and capacitance, while the voltage is made up of the two component voltages, V_R and V_C . The resulting voltage of these two components can be found mathematically but since vectors V_R and V_C are 90° out-of-phase, they can be added vectorially by constructing a vector diagram.

To be able to produce a vector diagram for an AC capacitance a reference or common component must be found. In a series AC circuit, the current is common and can therefore be used as the reference source because the same current flows through the resistance and into the capacitance. The individual vector diagrams for a pure resistance and a pure capacitance are given as:

Vector Diagrams for the Two Pure Components

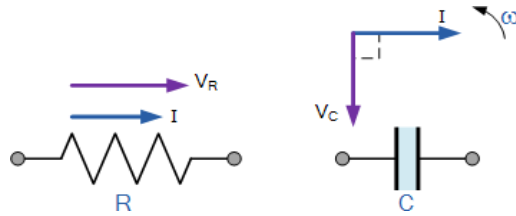

Both the voltage and current vectors for an **AC Resistance** are in phase with each other and therefore the voltage vector V_R is drawn superimposed to scale onto the current vector. Also, we know that the current leads the voltage (ICE) in a pure AC capacitance circuit, therefore the voltage vector V_C is drawn 90° behind (lagging) the current vector and to the same scale as V_R as shown.

Vector Diagram of the Resultant Voltage

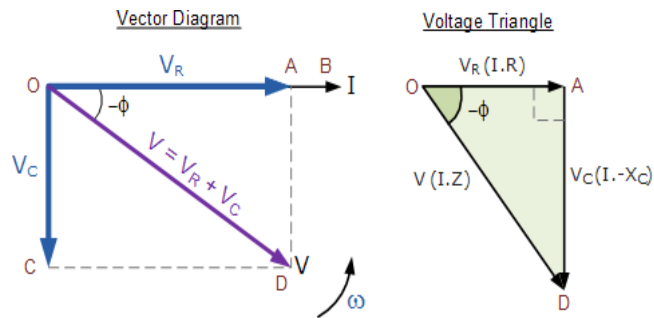

In the vector diagram above, line OB represents the horizontal current reference and line OA is the voltage across the resistive component which is in-phase with the current. Line OC shows the capacitive voltage which is 90° behind the current therefore it can still be seen that the current leads the purely capacitive voltage by 90° . Line OD gives us the resulting supply voltage.

As the current leads the voltage in a pure capacitance by 90° the resultant phasor diagram drawn from the individual voltage drops V_R and V_C represents a right-angled voltage triangle shown above as OAD. Then we can also use Pythagoras theorem to mathematically find the value of this resultant voltage across the resistor/capacitor (RC) circuit.

As $V_R = I.R$ and $V_C = I.X_C$ the applied voltage will be the vector sum of the two as follows.

$$V^2 = V_R^2 + V_C^2$$

$$V_R = I.R \quad \text{and} \quad V_C = I.X_C$$

$$V^2 = I^2.R^2 + I^2.X_C^2$$

$$V = \sqrt{(I.R)^2 + (I.X_C)^2}$$

$$\therefore I = \frac{V}{\sqrt{R^2 + X_C^2}} = \frac{V}{Z}$$

The quantity $\sqrt{R^2 + X_C^2}$ represents the **impedance**, Z of the circuit.

The Impedance of an AC Capacitance

Impedance, Z which has the units of Ohms, Ω is the "TOTAL" opposition to current flowing in an AC circuit that contains both Resistance, (the real part) and Reactance (the imaginary part). A purely resistive impedance will have a phase angle of 0° while a purely capacitive impedance will have a phase angle of -90° .

However, when resistors and capacitors are connected together in the same circuit, the total impedance will have a phase angle somewhere between 0° and 90° depending upon the value of the components used. Then the impedance of our simple RC circuit shown above can be found by using the impedance triangle.

The RC Impedance Triangle

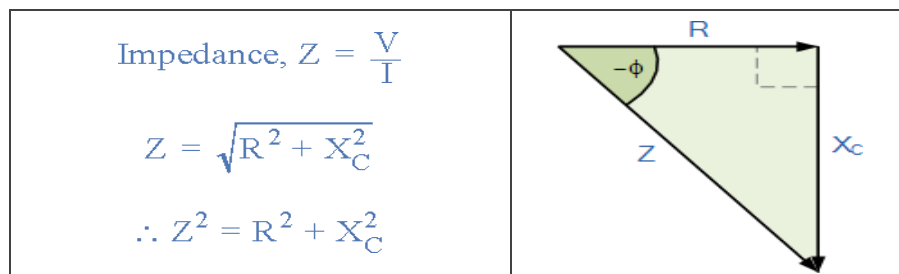

Then: $(\text{Impedance})^2 = (\text{Resistance})^2 + (j \text{ Reactance})^2$ where j represents the 90° phase shift.

This means then by using Pythagoras theorem the negative phase angle, θ between the voltage and current is calculated as.

Phase Angle

$$Z^2 = R^2 + X_C^2$$

$$\cos \phi = \frac{R}{Z}, \quad \sin \phi = \frac{X_C}{Z}, \quad \tan \phi = \frac{X_C}{R}$$

AC Capacitance Example No1

A single-phase sinusoidal AC supply voltage defined as: $V_{(t)} = 240 \sin(314t - 20^\circ)$ is connected to a pure AC capacitance of 200 μ F. Determine the value of the current flowing into the capacitor and draw the resulting phasor diagram.

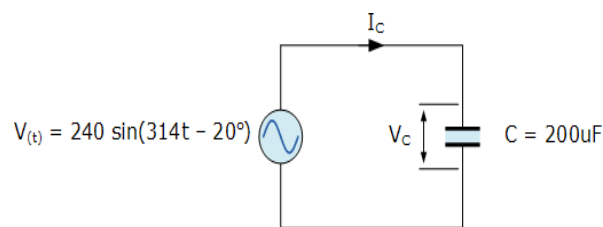

The voltage across the capacitor will be the same as the supply voltage. Converting this time domain value into polar form gives us: $V_c = 240 \angle -20^\circ$ (v). The capacitive reactance will be: $X_C = 1/(\omega \cdot 200\mu\text{F})$. Then the current flowing into the capacitor can be found using Ohms law as:

$$X_C = \frac{1}{j\omega C} = \frac{1}{314 \times 200\mu\text{F}} = 16 \angle -90^\circ$$

$$I_C = \frac{V_C}{jX_C} = \frac{240 \angle -20^\circ}{16 \angle -90^\circ} = 15 \angle 70^\circ \text{ (A)}$$

With the current leading the voltage by 90° in an AC capacitance circuit the phasor diagram will be.

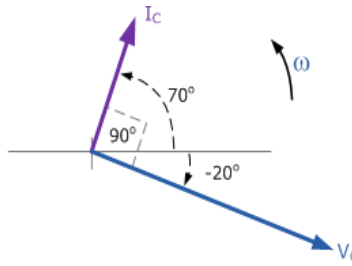

AC Capacitance Example No2

A capacitor which has an internal resistance of 10Ω and a capacitance value of $100\mu\text{F}$ is connected to a supply voltage given as $V(t) = 100 \sin(314t)$. Calculate the peak current flowing into the capacitor. Also construct a voltage triangle showing the individual voltage drops.

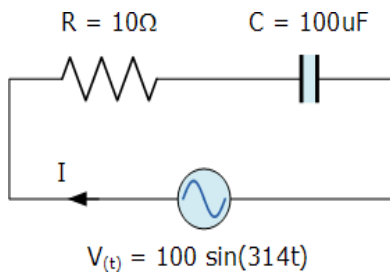

The capacitive reactance and circuit impedance is calculated as:

$$X_C = \frac{1}{\omega C} = \frac{1}{314 \times 100 \mu\text{F}} = 31.85 \Omega$$

$$Z = \sqrt{R^2 + X_C^2} = \sqrt{10^2 + 31.85^2} = 33.4 \Omega$$

Then the current flowing into the capacitor and the circuit is given as:

$$I = \frac{V_C}{Z} = \frac{100}{33.4} = 3 \text{ Amps}$$

The phase angle between the current and voltage is calculated from the impedance triangle above as:

$$\phi = \tan^{-1}\left(\frac{X_C}{R}\right) = \frac{31.85}{10} = 72.6^\circ \text{ leading}$$

Then the individual voltage drops around the circuit are calculated as:

$$V_R = I \times R = 3 \times 10 = 30V$$

$$V_C = I \times X_C = 3 \times 31.85 = 95.6V$$

$$V_S = \sqrt{V_R^2 + V_C^2} = \sqrt{30^2 + 95.6^2} = 100V$$

Then the resultant voltage triangle for the calculated peak values will be:

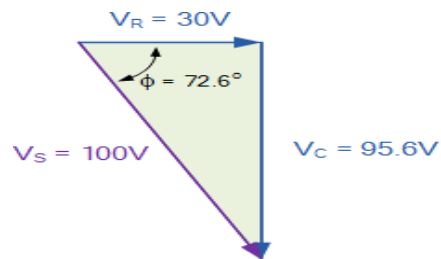

AC Capacitance Summary

In a pure **AC Capacitance** circuit, the voltage and current are both “out-of-phase” with the current leading the voltage by 90° and we can remember this by using the mnemonic expression “ICE”. The AC resistive value of a capacitor called impedance, (Z) is related to frequency with the reactive value of a capacitor called “capacitive reactance”, X_C . In an *AC Capacitance* circuit, this capacitive reactance value is equal to $1/(2\pi fC)$ or $1/(j\omega C)$

Thus far we have seen that the relationship between voltage and current is not the same and changes in all three pure passive components. In the *Resistance* the phase angle is 0° , in the *Inductance* it is $+90^\circ$ while in the *Capacitance* it is -90° .

8. Series RLC Circuit Analysis: -

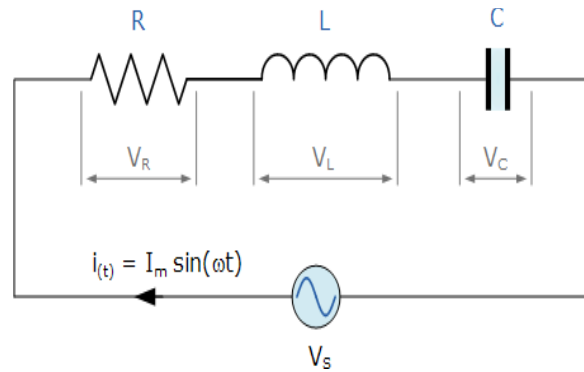

Series RLC circuits consist of a resistance, a capacitance and an inductance connected in series across an alternating supply

Thus far we have seen that the three basic passive components of: *Resistance*, *Inductance*, and *Capacitance* have very different phase relationships to each other when connected to a sinusoidal alternating supply.

In a pure ohmic resistor the voltage waveforms are “in-phase” with the current. In a pure inductance the voltage waveform “leads” the current by 90°, giving us the expression of: ELI. In a pure capacitance the voltage waveform “lags” the current by 90°, giving us the expression of: ICE.

This Phase Difference, Φ depends upon the reactive value of the components being used and hopefully by now we know that reactance, (X) is zero if the circuit element is resistive, positive if the circuit element is inductive and negative if it is capacitive thus giving their resulting impedances as:

Element Impedance

Resistor	R	0	$Z_R = R$ $= R \angle 0^\circ$
Inductor	0	ωL	$Z_L = j\omega L$ $= \omega L \angle +90^\circ$
Capacitor	0	$\frac{1}{\omega C}$	$Z_C = \frac{1}{j\omega C}$ $= \frac{1}{\omega C} \angle -90^\circ$

Instead of analyzing each passive element separately, we can combine all three together into a series RLC circuit. The analysis of a **series RLC circuit** is the same as that for the dual series R_L and R_C circuits we looked at previously, except this time we need to take into account the magnitudes of both X_L and X_C to

find the overall circuit reactance. Series RLC circuits are classed as second-order circuits because they contain two energy storage elements, an inductance L and a capacitance C. Consider the RLC circuit below.

Series RLC Circuit

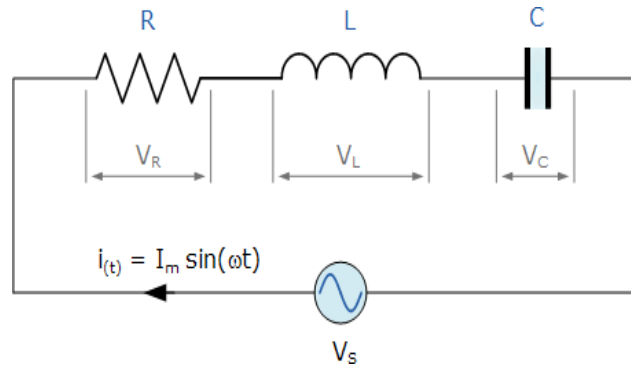

The series RLC circuit above has a single loop with the instantaneous current flowing through the loop being the same for each circuit element. Since the inductive and capacitive reactance's X_L and X_C are a function of the supply frequency, the sinusoidal response of a series RLC circuit will therefore vary with frequency, f . Then the individual voltage drops across each circuit element of R, L and C element will be "out-of-phase" with each other as defined by: $i(t) = I_{\max} \sin(\omega t)$

- The instantaneous voltage across a pure resistor, V_R is "in-phase" with current
- The instantaneous voltage across a pure inductor, V_L "leads" the current by 90°
- The instantaneous voltage across a pure capacitor, V_C "lags" the current by 90°
- Therefore, V_L and V_C are 180° "out-of-phase" and in opposition to each other.

For the series RLC circuit above, this can be shown as:

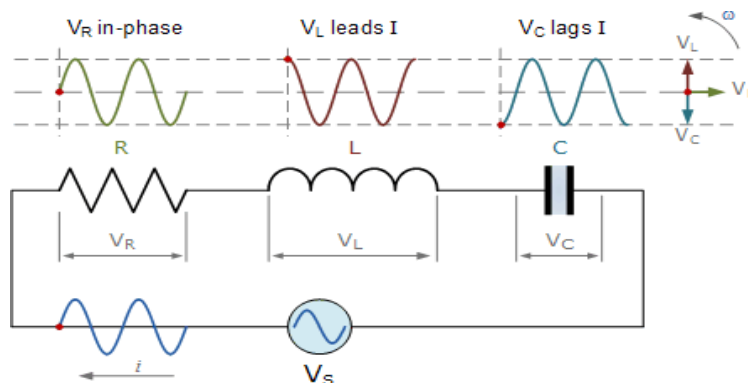

The amplitude of the source voltage across all three components in a series RLC circuit is made up of the three individual component voltages, V_R , V_L and V_C with the current common to all three components. The vector diagrams will therefore have the current vector as their reference with the three voltage vectors being plotted with respect to this reference as shown below.

Individual Voltage Vectors

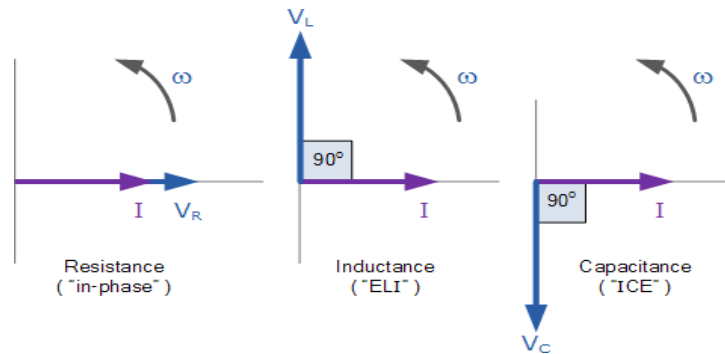

This means then that we can not simply add together V_R , V_L and V_C to find the supply voltage, V_S across all three components as all three voltage vectors point in different directions with regards to the current vector. Therefore, we will have to find the supply voltage, V_S as the **Phasor Sum** of the three component voltages combined together vectorially.

Kirchhoff's voltage law (KVL) for both loop and nodal circuits states that around any closed loop the sum of voltage drops around the loop equals the sum of the EMF's. Then applying this law to these three voltages will give us the amplitude of the source voltage, V_S as.

Instantaneous Voltages for a Series RLC Circuit

$$\text{KVL: } V_S - V_R - V_L - V_C = 0$$

$$V_S - IR - L \frac{di}{dt} - \frac{Q}{C} = 0$$

$$\therefore V_S = IR + L \frac{di}{dt} + \frac{Q}{C}$$

The phasor diagram for a series RLC circuit is produced by combining together the three individual phasors above and adding these voltages vectorially. Since the current flowing through the circuit is common to all three circuit elements, we can use this as the reference vector with the three voltage vectors drawn relative to this at their corresponding angles.

The resulting vector V_S is obtained by adding together two of the vectors, V_L and V_C and then adding this sum to the remaining vector V_R . The resulting angle obtained between V_S and i will be the circuits phase angle as shown below.

Phasor Diagram for a Series RLC Circuit

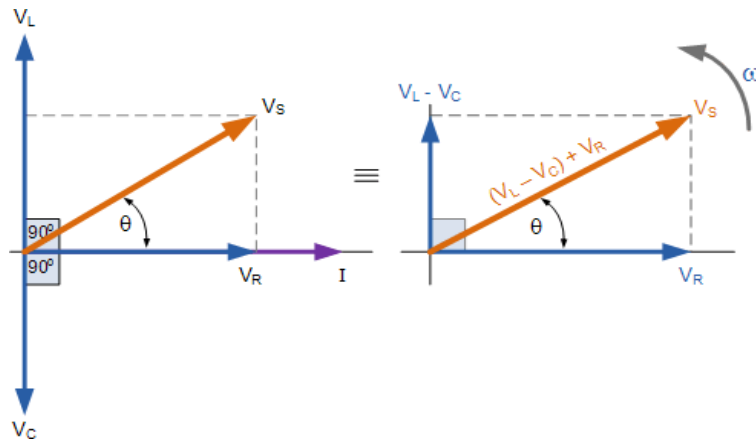

We can see from the phasor diagram on the right-hand side above that the voltage vectors produce a rectangular triangle, comprising of hypotenuse V_S , horizontal axis V_R and vertical axis $V_L - V_C$. Hopefully you will notice then, that this forms our old favored the **Voltage Triangle** and we can therefore use Pythagoras's theorem on this voltage triangle to mathematically obtain the value of V_S as shown.

Voltage Triangle for a Series RLC Circuit

$$V_S^2 = V_R^2 + (V_L - V_C)^2$$

$$V_S = \sqrt{V_R^2 + (V_L - V_C)^2}$$

Please note that when using the above equation, the final reactive voltage must always be positive in value, that is the smallest voltage must always be taken away from the largest voltage we can not have a negative voltage added to V_R so it is correct to have $V_L - V_C$ or $V_C - V_L$. The smallest value from the largest otherwise the calculation of V_S will be incorrect.

We know from above that the current has the same amplitude and phase in all the components of a series RLC circuit. Then the voltage across each component can also be described mathematically according to the current flowing through, and the voltage across each element as.

$$V_R = iR \sin(\omega t + 0^\circ) = i.R$$

$$V_L = iX_L \sin(\omega t + 90^\circ) = i.j\omega L$$

$$V_C = iX_C \sin(\omega t - 90^\circ) = i.\frac{1}{j\omega C}$$

By substituting these values into the Pythagoras equation above for the voltage triangle will give us:

$$V_R = I.R \quad V_L = I.X_L \quad V_C = I.X_C$$

$$V_S = \sqrt{(I.R)^2 + (I.X_L - I.X_C)^2}$$

$$V_S = I.\sqrt{R^2 + (X_L - X_C)^2}$$

$$\therefore V_S = I \times Z \quad \text{where: } Z = \sqrt{R^2 + (X_L - X_C)^2}$$

So, we can see that the amplitude of the source voltage is proportional to the amplitude of the current flowing through the circuit. This proportionality constant is called the **Impedance** of the circuit which ultimately depends upon the resistance and the inductive and capacitive reactance's.

Then in the series RLC circuit above, it can be seen that the opposition to current flow is made up of three components, X_L , X_C and R with the reactance, X_T of any series RLC circuit being defined as: $X_T = X_L - X_C$ or $X_T = X_C - X_L$ whichever is greater. Thus, the total impedance of the circuit being thought of as the voltage source required to drive a current through it.

The Impedance of a Series RLC Circuit

As the three vector voltages are out-of-phase with each other, X_L , X_C and R must also be "out-of-phase" with each other with the relationship between R , X_L and X_C being the vector sum of these three components. This will give us the RLC circuits overall impedance, Z . These circuit impedance's can be drawn and represented by an **Impedance Triangle** as shown below.

The Impedance Triangle for a Series RLC Circuit

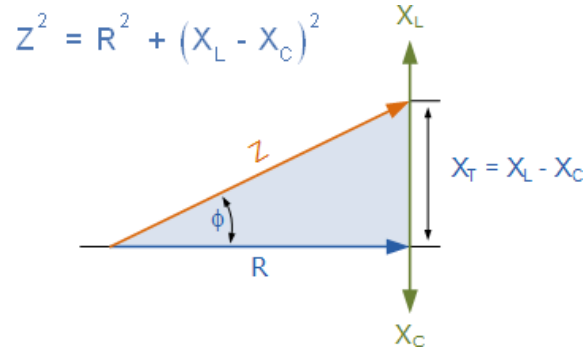

The impedance Z of a series RLC circuit depends upon the angular frequency, ω as do X_L and X_C . If the capacitive reactance is greater than the inductive reactance, $X_C > X_L$ then the overall circuit reactance is capacitive giving a leading phase angle.

Likewise, if the inductive reactance is greater than the capacitive reactance, $X_L > X_C$ then the overall circuit reactance is inductive giving the series circuit a lagging phase angle. If the two reactance's are the same and $X_L = X_C$ then the angular frequency at which this occurs is called the resonant frequency and produces the effect of **resonance** which we will look at in more detail in another tutorial.

Then the magnitude of the current depends upon the frequency applied to the series RLC circuit. When impedance, Z is at its maximum, the current is a minimum and likewise, when Z is at its minimum, the current is at maximum. So, the above equation for impedance can be re-written as:

$$\text{Impedance, } Z = \sqrt{R^2 + \left(\omega L - \frac{1}{\omega C}\right)^2}$$

The phase angle, θ between the source voltage, V_s and the current, i is the same as for the angle between Z and R in the impedance triangle. This phase angle may be positive or negative in value depending on whether the source voltage leads or lags the circuit current and can be calculated mathematically from the ohmic values of the impedance triangle as:

$$\cos\phi = \frac{R}{Z} \quad \sin\phi = \frac{X_L - X_C}{Z} \quad \tan\phi = \frac{X_L - X_C}{R}$$

Series RLC Circuit Example No1

A series RLC circuit containing a resistance of 12Ω , an inductance of 0.15H and a capacitor of $100\mu\text{F}$ are connected in series across a 100V , 50Hz supply. Calculate the total circuit impedance, the circuits current, power factor and draw the voltage phasor diagram.

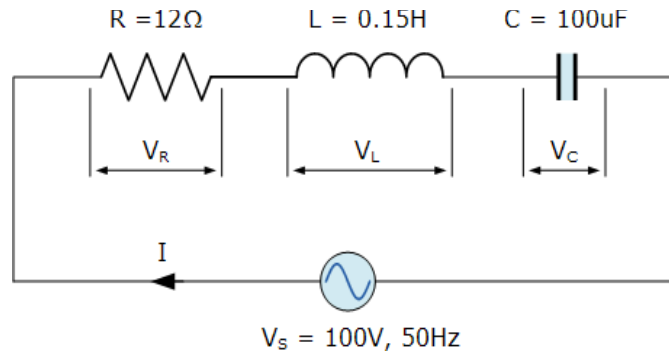

Inductive Reactance, X_L .

$$X_L = 2\pi fL = 2\pi \times 50 \times 0.15 = 47.13\Omega$$

Capacitive Reactance, X_C .

$$X_C = \frac{1}{2\pi fC} = \frac{1}{2\pi \times 50 \times 100 \times 10^{-6}} = 31.83\Omega$$

Circuit Impedance, Z .

$$Z = \sqrt{R^2 + (X_L - X_C)^2}$$

$$Z = \sqrt{12^2 + (47.13 - 31.83)^2}$$

$$Z = \sqrt{144 + 234} = 19.4\Omega$$

Circuits Current, I .

$$I = \frac{V_s}{Z} = \frac{100}{19.4} = 5.14\text{Amps}$$

Voltages across the Series RLC Circuit, V_R , V_L , V_C .

$$V_R = I \times R = 5.14 \times 12 = 61.7 \text{ volts}$$

$$V_L = I \times X_L = 5.14 \times 47.13 = 242.2 \text{ volts}$$

$$V_C = I \times X_C = 5.14 \times 31.8 = 163.5 \text{ volts}$$

Circuits Power factor and Phase Angle, θ .

$$\cos \phi = \frac{R}{Z} = \frac{12}{19.4} = 0.619$$

$$\therefore \cos^{-1} 0.619 = 51.8^\circ \text{ lagging}$$

Phasor Diagram.

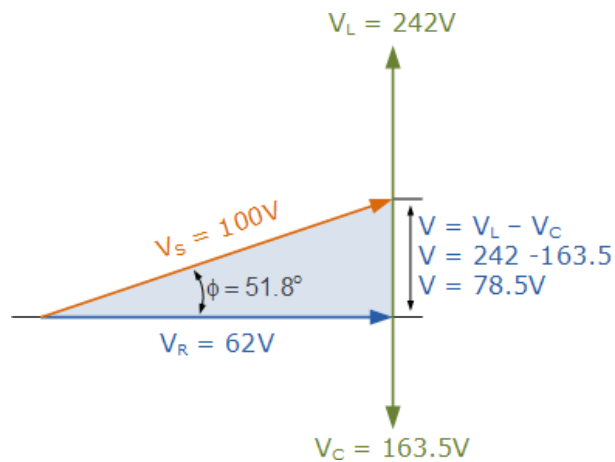

Since the phase angle θ is calculated as a positive value of 51.8° the overall reactance of the circuit must be inductive. As we have taken the current vector as our reference vector in a series RLC circuit, then the current “lags” the source voltage by 51.8° so we can say that the phase angle is lagging as confirmed by our mnemonic expression “ELI”.

Series RLC Circuit Summary

In a **series RLC circuit** containing a resistor, an inductor and a capacitor the source voltage V_S is the phasor sum made up of three components, V_R , V_L and V_C with the current common to all three. Since the current is common to all three components it is used as the horizontal reference when constructing a voltage triangle.

The impedance of the circuit is the total opposition to the flow of current. For a series RLC circuit, and impedance triangle can be drawn by dividing each side of the voltage triangle by its current, I . The voltage drop across the resistive element is equal to $I \cdot R$, the voltage across the two reactive elements is $I \cdot X = I \cdot X_L - I \cdot X_C$ while the source voltage is equal to $I \cdot Z$. The angle between V_S and I will be the phase angle, θ .

When working with a series RLC circuit containing multiple resistances, capacitances or inductances either pure or impure, they can be all added together to form a single component. For example, all resistances are added together, $R_T = (R_1 + R_2 + R_3) \dots$ etc or all the inductance's $L_T = (L_1 + L_2 + L_3) \dots$ etc this way a circuit containing many elements can be easily reduced to a single impedance.

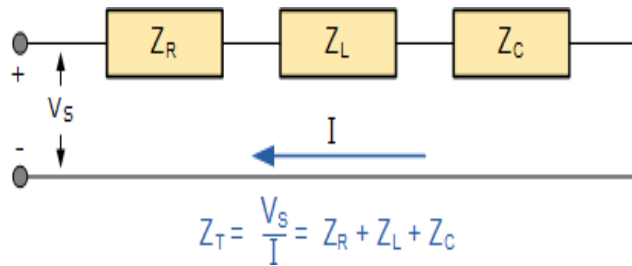

9. Parallel RLC Circuit Analysis: -

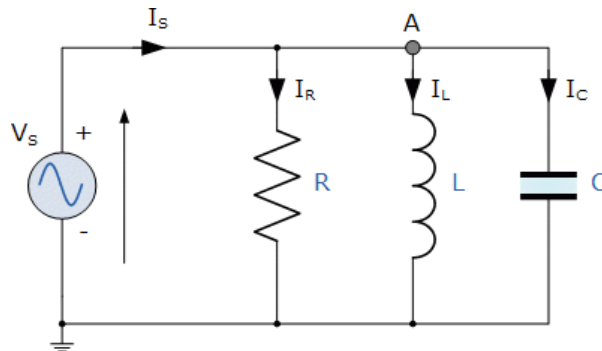

The **Parallel RLC Circuit** is the exact opposite to the series circuit we looked at in the previous tutorial although some of the previous concepts and equations still apply.

However, the analysis of a *parallel RLC circuits* can be a little more mathematically difficult than for series RLC circuits so in this tutorial about parallel RLC circuits only pure components are assumed in this tutorial to keep things simple.

This time instead of the current being common to the circuit components, the applied voltage is now common to all so we need to find the individual branch currents through each element. The total

impedance, Z of a parallel RLC circuit is calculated using the current of the circuit similar to that for a DC parallel circuit, the difference this time is that admittance is used instead of impedance. Consider the parallel RLC circuit below.

Parallel RLC Circuit

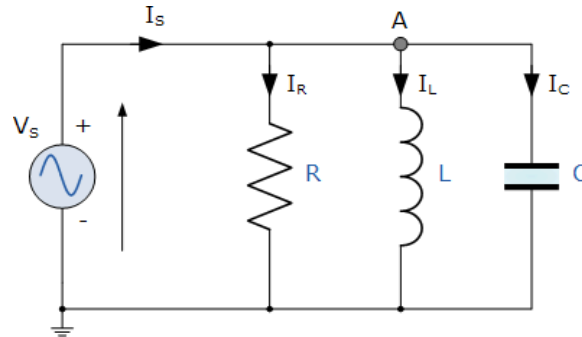

In the above parallel RLC circuit, we can see that the supply voltage, V_s is common to all three components whilst the supply current I_s consisting of three parts. The current flowing through the resistor, I_R , the current flowing through the inductor, I_L and the current through the capacitor, I_C .

But the current flowing through each branch and therefore each component will be different to each other and also to the supply current, I_s . The total current drawn from the supply will not be the mathematical sum of the three individual branch currents but their vector sum.

Like the series RLC circuit, we can solve this circuit using the phasor or vector method but this time the vector diagram will have the voltage as its reference with the three current vectors plotted with respect to the voltage. The phasor diagram for a parallel RLC circuit is produced by combining together the three individual phasors for each component and adding the currents vectorially.

Since the voltage across the circuit is common to all three circuit elements, we can use this as the reference vector with the three current vectors drawn relative to this at their corresponding angles. The resulting vector current I_s is obtained by adding together two of the vectors, I_L and I_C and then adding this sum to the remaining vector I_R . The resulting angle obtained between V and I_s will be the circuit's phase angle as shown below.

Phasor Diagram for a Parallel RLC Circuit

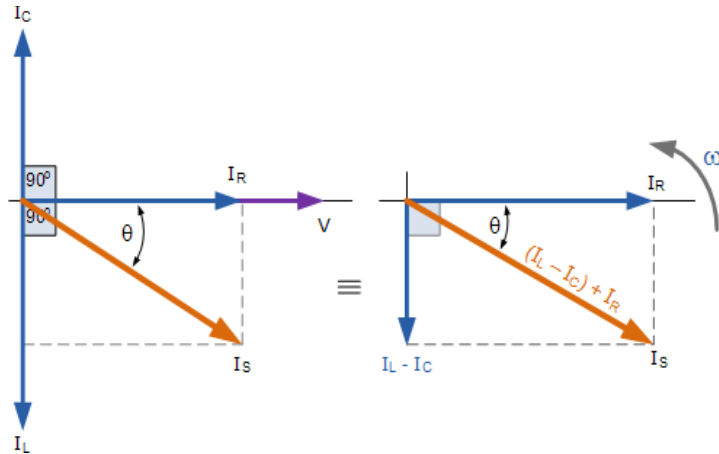

We can see from the phasor diagram on the right-hand side above that the current vectors produce a rectangular triangle, comprising of hypotenuse I_S , horizontal axis I_R and vertical axis $I_L - I_C$. Hopefully you will notice then, that this forms a **Current Triangle**. We can therefore use Pythagoras's theorem on this current triangle to mathematically obtain the individual magnitudes of the branch currents along the x-axis and y-axis which will determine the total supply current I_S of these components as shown.

Current Triangle for a Parallel RLC Circuit

$$I_S^2 = I_R^2 + (I_L - I_C)^2$$

$$I_S = \sqrt{I_R^2 + (I_L - I_C)^2}$$

$$\therefore I_S = \sqrt{\left(\frac{V}{R}\right)^2 + \left(\frac{V}{X_L} - \frac{V}{X_C}\right)^2} = \frac{V}{Z}$$

$$\text{where: } I_R = \frac{V}{R}, \quad I_L = \frac{V}{X_L}, \quad I_C = \frac{V}{X_C}$$

Since the voltage across the circuit is common to all three circuit elements, the current through each branch can be found using Kirchhoff's Current Law, (KCL). Remember that Kirchhoff's current law or junction law states that "the total current entering a junction or node is exactly equal to the current leaving that node". Thus, the currents entering and leaving node "A" above are given as:

$$\text{KCL: } I_s - I_R - I_L - I_C = 0$$

$$I_s - \frac{V}{R} - \frac{1}{L} \int v dt - C \frac{dv}{dt} = 0$$

Taking the derivative, dividing through the above equation by C and then re-arranging gives us the following Second-order equation for the circuit current. It becomes a second-order equation because there are two reactive elements in the circuit, the inductor and the capacitor.

$$I_s - \frac{d^2V}{dt^2} - \frac{dV}{RCdt} - \frac{V}{LC} = 0$$

$$\therefore I_{s(t)} = \frac{d^2V}{dt^2} + \frac{dV}{dt} \frac{1}{RC} + \frac{1}{LC} V$$

The opposition to current flow in this type of AC circuit is made up of three components: X_L , X_C and R with the combination of these three values giving the circuit's impedance, Z . We know from above that the voltage has the same amplitude and phase in all the components of a parallel RLC circuit. Then the impedance across each component can also be described mathematically according to the current flowing through, and the voltage across each element as.

Impedance of a Parallel RLC Circuit

$$R = \frac{V}{I_R} \quad X_L = \frac{V}{I_L} \quad X_C = \frac{V}{I_C}$$

$$Z = \frac{1}{\sqrt{\left(\frac{1}{R}\right)^2 + \left(\frac{1}{X_L} - \frac{1}{X_C}\right)^2}}$$

$$\therefore \frac{1}{Z} = \sqrt{\left(\frac{1}{R}\right)^2 + \left(\frac{1}{X_L} - \frac{1}{X_C}\right)^2}$$

You will notice that the final equation for a parallel RLC circuit produces complex impedances for each parallel branch as each element becomes the reciprocal of impedance, $(1/Z)$. The reciprocal of impedance is commonly called **Admittance**, symbol (Y).

In parallel AC circuits it is generally more convenient to use admittance to solve complex branch impedance's especially when two or more parallel branch impedances are involved (helps with the math's). The total admittance of the circuit can simply be found by the addition of the parallel admittances. Then the total impedance, Z_T of the circuit will therefore be $1/Y_T$ Siemens as shown.

Admittance of a Parallel RLC Circuit

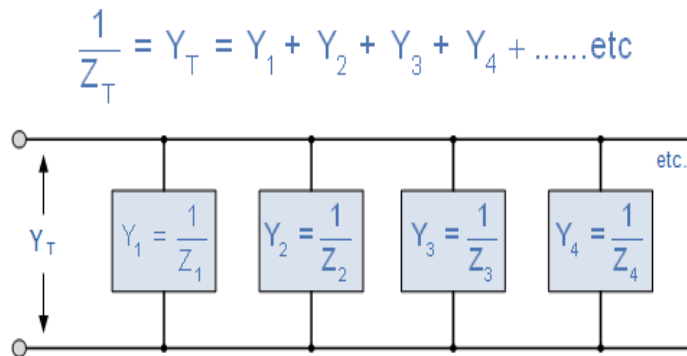

The unit of measurement now commonly used for admittance is the *Siemens*, abbreviated as S, (old unit mho's \mathcal{U} , ohm's in reverse). Admittances are added together in parallel branches, whereas impedances are added together in series branches. But if we can have a reciprocal of impedance, we can also have a reciprocal of resistance and reactance as impedance consists of two components, R and X. Then the reciprocal of resistance is called **Conductance** and the reciprocal of reactance is called **Susceptance**.

Conductance, Admittance and Susceptance

The units used for **conductance**, **admittance** and **susceptance** are all the same namely **Siemens (S)**, which can also be thought of as the **reciprocal of Ohms or ohm^{-1}** , but the symbol used for each element is different and in a pure component this is given as:

Admittance (Y) :

Admittance is the reciprocal of impedance, Z and is given the symbol Y. In AC circuits admittance is defined as the ease at which a circuit composed of resistances and reactances allows current to flow when a voltage is applied taking into account the phase difference between the voltage and the current.

The admittance of a parallel circuit is the ratio of phasor current to phasor voltage with the angle of the admittance being the negative to that of impedance.

$$Y = \frac{1}{Z} \text{ [S]}$$

Conductance (G) :

Conductance is the reciprocal of resistance, R and is given the symbol G. Conductance is defined as the ease at which a resistor (or a set of resistors) allows current to flow when a voltage, either AC or DC is applied.

$$G = \frac{1}{R} \text{ [S]}$$

Susceptance (B) :

Susceptance is the reciprocal of a pure reactance, X and is given the symbol B. In AC circuits susceptance is defined as the ease at which a reactance (or a set of reactances) allows an alternating current to flow when a voltage of a given frequency is applied.

Susceptance has the opposite sign to reactance so Capacitive susceptance B_C is positive, (+ve) in value while Inductive susceptance B_L is negative, (-ve) in value.

$$B_L = \frac{1}{X_L} \text{ [S]}$$

$$B_C = \frac{1}{X_C} \text{ [S]}$$

We can therefore define inductive and capacitive susceptance as being:

$$B_L = B \angle -90^\circ = 0 - jB \text{ and } B_C = B \angle +90^\circ = 0 + jB$$

In AC series circuits the opposition to current flow is impedance, Z which has two components, resistance R and reactance, X and from these two components we can construct an impedance triangle. Similarly, in a parallel RLC circuit, admittance, Y also has two components, conductance, G and susceptance, B. This makes it possible to construct an **admittance triangle** that has a horizontal conductance axis, G and a vertical susceptance axis, jB as shown.

Admittance Triangle for a Parallel RLC Circuit

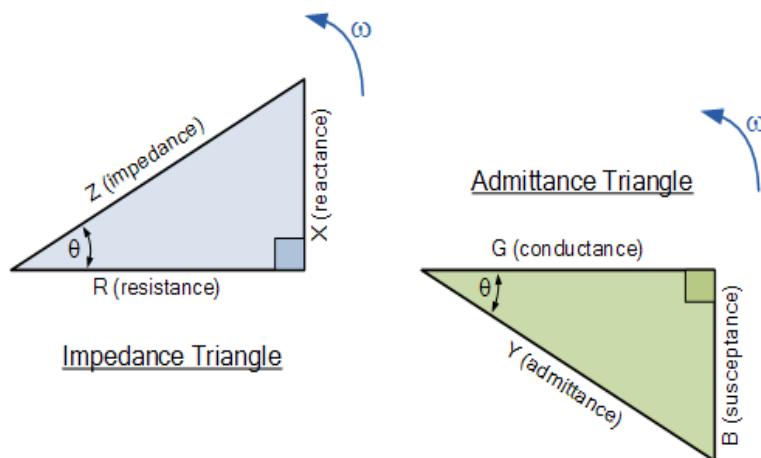

Now that we have an admittance triangle, we can use Pythagoras to calculate the magnitudes of all three sides as well as the phase angle as shown.

from Pythagoras

$$Y = \sqrt{G^2 + (B_L - B_C)^2}$$

$$\text{where: } Y = \frac{1}{Z} \quad G = \frac{1}{R}$$

$$B_L = \frac{1}{\omega L} \quad B_C = \omega C$$

Then we can define both the admittance of the circuit and the impedance with respect to admittance as:

$$\text{Admittance: } Y = \sqrt{\left(\frac{1}{R}\right)^2 + \left(\frac{1}{\omega L} - \omega C\right)^2}$$

$$\text{Impedance: } Z = \frac{1}{Y} = \frac{1}{\sqrt{\left(\frac{1}{R}\right)^2 + \left(\frac{1}{\omega L} - \omega C\right)^2}}$$

Giving us a power factor angle of:

$$\cos \phi = \frac{G}{Y} \quad \phi = \cos^{-1}\left(\frac{G}{Y}\right)$$

or

$$\tan \phi = \frac{B}{G} \quad \phi = \tan^{-1}\left(\frac{B}{G}\right)$$

As the admittance, Y of a parallel RLC circuit is a complex quantity, the admittance corresponding to the general form of impedance $Z = R + jX$ for series circuits will be written as $Y = G - jB$ for parallel circuits where the real part G is the conductance and the imaginary part jB is the susceptance. In polar form this will be given as:

$$Y = G + jB = \sqrt{G^2 + B^2} \angle \tan^{-1} \frac{B}{G}$$

Parallel RLC Circuit Example No1

A $1\text{k}\Omega$ resistor, a 142mH coil and a $160\mu\text{F}$ capacitor are all connected in parallel across a 240V , 60Hz supply. Calculate the impedance of the parallel RLC circuit and the current drawn from the supply.

Impedance of a Parallel RLC Circuit

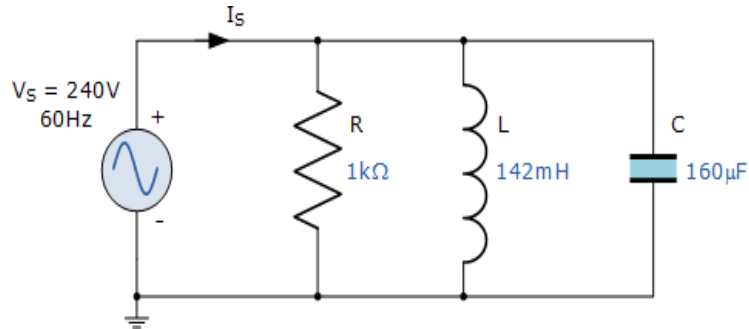

In an AC circuit, the resistor is unaffected by frequency therefore $R = 1\text{k}\Omega$

Inductive Reactance, (X_L):

$$X_L = \omega L = 2\pi fL = 2\pi \cdot 60 \cdot 142 \times 10^{-3} = 53.54\Omega$$

Capacitive Reactance, (X_C):

$$X_C = \frac{1}{\omega C} = \frac{1}{2\pi fC} = \frac{1}{2\pi \cdot 60 \cdot 160 \times 10^{-6}} = 16.58\Omega$$

Impedance, (Z):

$$Z = \frac{1}{\sqrt{\left(\frac{1}{R}\right)^2 + \left(\frac{1}{X_L} - \frac{1}{X_C}\right)^2}} = \frac{1}{\sqrt{\left(\frac{1}{1000}\right)^2 + \left(\frac{1}{53.54} - \frac{1}{16.58}\right)^2}}$$

$$Z = \frac{1}{\sqrt{1.0 \times 10^{-6} + 1.734 \times 10^{-3}}} = \frac{1}{0.0417} = 24.0\Omega$$

Supply Current, (I_S):

$$I_S = \frac{V_S}{Z} = \frac{240}{24} = 10 \text{ Amperes}$$

A 50Ω resistor, a 20mH coil and a 5μF capacitor are all connected in parallel across a 50V, 100Hz supply. Calculate the total current drawn from the supply, the current for each branch, the total impedance of the circuit and the phase angle. Also construct the current and admittance triangles representing the circuit.

Parallel RLC Circuit

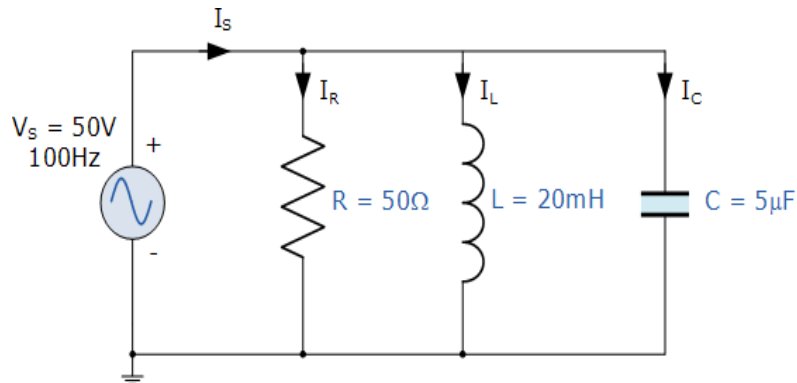

1). Inductive Reactance, (X_L):

$$X_L = \omega L = 2\pi fL = 2\pi \cdot 100 \cdot 0.02 = 12.6\Omega$$

2). Capacitive Reactance, (X_C):

$$X_C = \frac{1}{\omega C} = \frac{1}{2\pi fC} = \frac{1}{2\pi \cdot 100 \cdot 5 \times 10^{-6}} = 318.3\Omega$$

3). Impedance, (Z):

$$Z = \frac{1}{\sqrt{\left(\frac{1}{R}\right)^2 + \left(\frac{1}{X_C} - \frac{1}{X_L}\right)^2}} = \frac{1}{\sqrt{\left(\frac{1}{50}\right)^2 + \left(\frac{1}{318.3} - \frac{1}{12.6}\right)^2}}$$

$$Z = \frac{1}{\sqrt{0.0004 + 0.0058}} = \frac{1}{0.0788} = 12.7\Omega$$

4). Current through resistance, R (I_R):

$$I_R = \frac{V}{R} = \frac{50}{50} = 1.0(A)$$

5). Current through inductor, L (I_L):

$$I_L = \frac{V}{X_L} = \frac{50}{12.6} = 3.9(A)$$

6). Current through capacitor, C (I_C):

$$I_C = \frac{V}{X_C} = \frac{50}{318.3} = 0.16 \text{ (A)}$$

7). Total supply current, (I_S):

$$I_S = \sqrt{I_R^2 + (I_L - I_C)^2} = \sqrt{1^2 + (3.9 - 0.16)^2} = 3.87 \text{ (A)}$$

8). Conductance, (G):

$$G = \frac{1}{R} = \frac{1}{50} = 0.02\text{S or } 20\text{mS}$$

9). Inductive Susceptance, (B_L):

$$B_L = \frac{1}{X_L} = \frac{1}{12.6} = 0.08\text{S or } 80\text{mS}$$

10). Capacitive Susceptance, (B_C):

$$B_C = \frac{1}{X_C} = \frac{1}{318.3} = 0.003\text{S or } 3\text{mS}$$

11). Admittance, (Y):

$$Y = \frac{1}{Z} = \frac{1}{12.7} = 0.078\text{S or } 78\text{mS}$$

12). Phase Angle, (ϕ) between the resultant current and the supply voltage:

$$\cos\phi = \frac{G}{Y} = \frac{20\text{mS}}{78\text{mS}} = 0.256$$

$$\phi = \cos^{-1} 0.256 = 75.3^\circ \text{ (lag)}$$

Current and Admittance Triangles

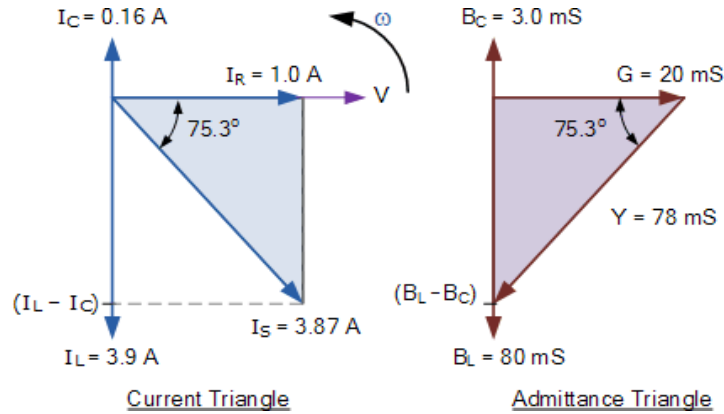

Parallel RLC Circuit Summary

In a **parallel RLC circuit** containing a resistor, an inductor and a capacitor the circuit current I_S is the phasor sum made up of three components, I_R , I_L and I_C with the supply voltage common to all three. Since the supply voltage is common to all three components it is used as the horizontal reference when constructing a current triangle.

Parallel RLC networks can be analyzed using vector diagrams just the same as with series RLC circuits. However, the analysis of parallel RLC circuits is a little more mathematically difficult than for series RLC circuits when it contains two or more current branches. So, an AC parallel circuit can be easily analyzed using the reciprocal of impedance called **Admittance**.

Admittance is the reciprocal of impedance given the symbol, Y . Like impedance, it is a complex quantity consisting of a real part and an imaginary part. The real part is the reciprocal of resistance and is called **Conductance**, symbol G while the imaginary part is the reciprocal of reactance and is called **Susceptance**, symbol B and expressed in complex form as: $Y = G + jB$ with the duality between the two complex impedance's being defined as:

Voltage, (V)	Current, (I)
Resistance, (R)	Conductance, (G)
Reactance, (X)	Susceptance, (B)
Impedance, (Z)	Admittance, (Y)

As susceptance is the reciprocal of reactance, in an inductive circuit, inductive susceptance, B_L will be negative in value and in a capacitive circuit, capacitive susceptance, B_C will be positive in value. The exact opposite to X_L and X_C respectively.

We have seen so far that series and parallel RLC circuits contain both capacitive reactance and inductive reactance within the same circuit. If we vary the frequency across these circuits there must become a point where the capacitive reactance value equals that of the inductive reactance and therefore, $X_C = X_L$.

The frequency point at which this occurs is called resonance and in the next tutorial we will look at series resonance and how its presence alters the characteristics of the circuit.

10. Series Resonance Circuit: -

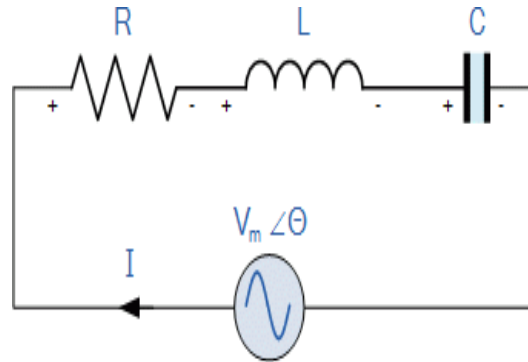

Resonance occurs in a series circuit when the supply frequency causes the voltages across L and C to be equal and opposite in phase

In a series RLC circuit there becomes a frequency point where the inductive reactance of the inductor becomes equal in value to the capacitive reactance of the capacitor. In other words, $X_L = X_C$. The point at which this occurs is called the **Resonant Frequency** point, (f_r) of the circuit, and as we are analyzing a series RLC circuit this resonance frequency produces a **Series Resonance**.

Series Resonance circuits are one of the most important circuits used electrical and electronic circuits. They can be found in various forms such as in AC mains filters, noise filters and also in radio and television tuning circuits producing a very selective tuning circuit for the receiving of the different frequency channels. Consider the simple series RLC circuit below.

Series RLC Circuit

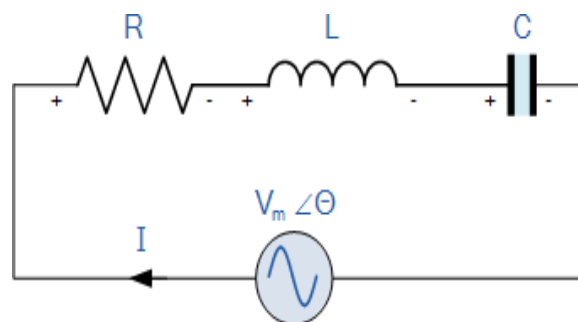

Firstly, let us define what we already know about series RLC circuits.

- Inductive reactance: $X_L = 2\pi fL = \omega L$
- Capacitive reactance: $X_C = \frac{1}{2\pi fC} = \frac{1}{\omega C}$
- When $X_L > X_C$ the circuit is Inductive
- When $X_C > X_L$ the circuit is Capacitive
- Total circuit reactance = $X_T = X_L - X_C$ or $X_C - X_L$
- Total circuit impedance = $Z = \sqrt{R^2 + X_T^2} = R + jX$

From the above equation for inductive reactance, if either the **Frequency** or the **Inductance** is increased the overall inductive reactance value of the inductor would also increase. As the frequency approaches infinity, the inductors reactance would also increase towards infinity with the circuit element acting like an open circuit.

However, as the frequency approaches zero or DC, the inductors reactance would decrease to zero, causing the opposite effect acting like a short circuit. This means then that inductive reactance is “**Proportional**” to frequency and is small at low frequencies and high at higher frequencies and this demonstrated in the following curve:

Inductive Reactance against Frequency

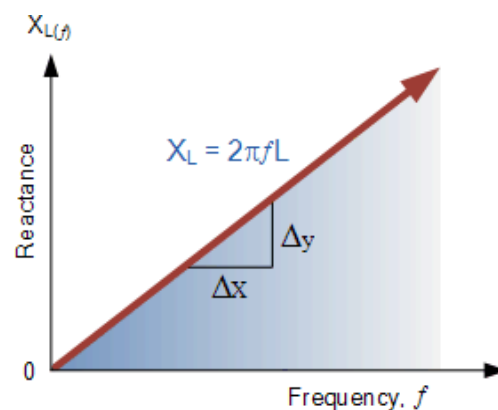

The graph of inductive reactance against frequency is a straight-line linear curve. The inductive reactance value of an inductor increases linearly as the frequency across it increases. Therefore, inductive reactance is positive and is directly proportional to frequency ($X_L \propto f$)

The same is also true for the capacitive reactance formula above but in reverse. If either the **Frequency** or the **Capacitance** is increased the overall capacitive reactance would decrease. As the frequency approaches infinity, the capacitors reactance would reduce to practically zero causing the circuit element to act like a perfect conductor of 0Ω .

But as the frequency approaches zero or DC level, the capacitors reactance would rapidly increase up to infinity causing it to act like a very large resistance, becoming more like an open circuit condition. This means then that capacitive reactance is “**Inversely proportional**” to frequency for any given value of capacitance and this shown below:

Capacitive Reactance against Frequency

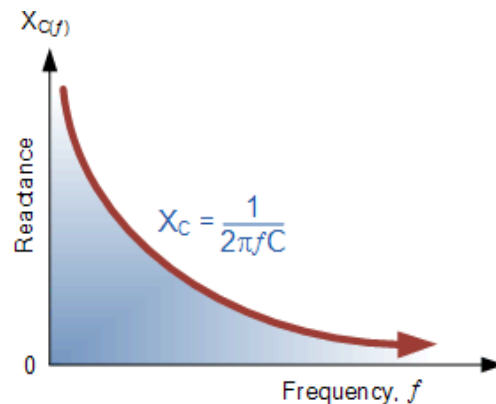

The graph of capacitive reactance against frequency is a hyperbolic curve. The Reactance value of a capacitor has a very high value at low frequencies but quickly decreases as the frequency across it increases. Therefore, capacitive reactance is negative and is inversely proportional to frequency ($X_C \propto f^{-1}$)

We can see that the values of these resistances depend upon the frequency of the supply. At a higher frequency X_L is high and at a low frequency X_C is high. Then there must be a frequency point where the value of X_L is the same as the value of X_C and there is. If we now place the curve for inductive reactance on top of the curve for capacitive reactance so that both curves are on the same axes, the point of intersection will give us the series resonance frequency point, (f_r or ω_r) as shown below.

Series Resonance Frequency

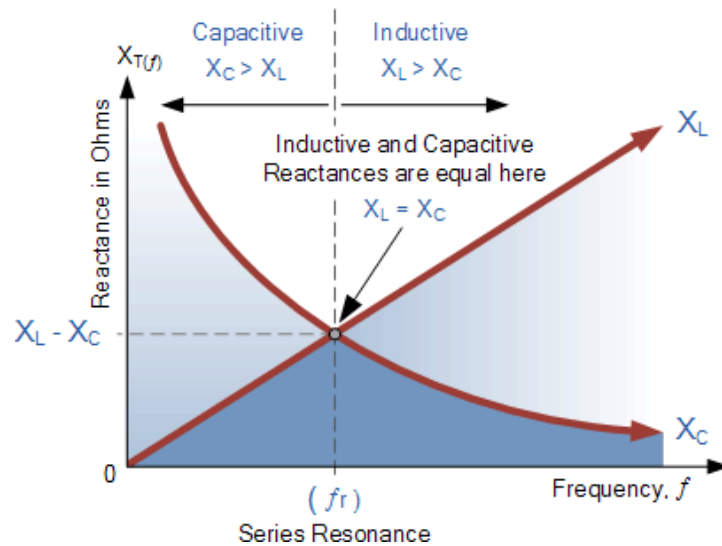

where: f_r is in Hertz, L is in Henries and C is in Farads.

Electrical resonance occurs in an AC circuit when the two reactances which are opposite and equal cancel each other out as $X_L = X_C$ and the point on the graph at which this happens is where the two reactance curves cross each other. In a series resonant circuit, the resonant frequency, f_r point can be calculated as follows.

$$X_L = X_C \Rightarrow 2\pi fL = \frac{1}{2\pi fC}$$

$$f^2 = \frac{1}{2\pi L \times 2\pi C} = \frac{1}{4\pi^2 LC}$$

$$f = \sqrt{\frac{1}{4\pi^2 LC}}$$

$$\therefore f_r = \frac{1}{2\pi\sqrt{LC}} \text{ (Hz)} \quad \text{or} \quad \omega_r = \frac{1}{\sqrt{LC}} \text{ (rads)}$$

We can see then that at resonance, the two reactances cancel each other out thereby making a series LC combination act as a short circuit with the only opposition to current flow in a series resonance circuit being the resistance, R . In complex form, the resonant frequency is the frequency at which the total impedance of a series RLC circuit becomes purely "real", that is no imaginary impedance's exist. This is because at resonance they are cancelled out. So, the total impedance of the series circuit becomes just the value of the resistance and therefore: $Z = R$.

Then at resonance the impedance of the series circuit is at its minimum value and equal only to the resistance, R of the circuit. The circuit impedance at resonance is called the "dynamic impedance" of the

circuit and depending upon the frequency, X_C (typically at high frequencies) or X_L (typically at low frequencies) will dominate either side of resonance as shown below.

Impedance in a Series Resonance Circuit

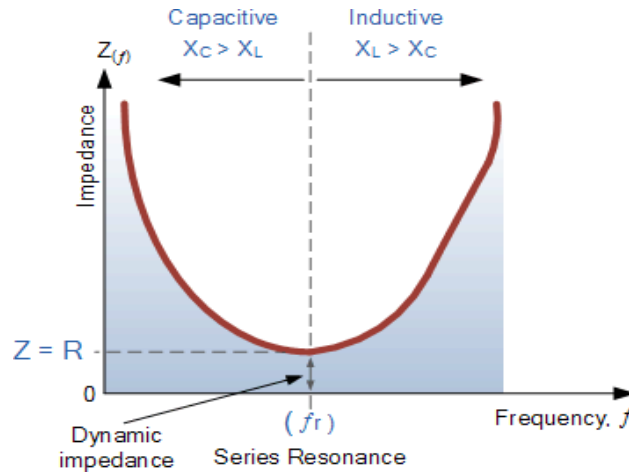

Note that when the capacitive reactance dominates the circuit the impedance curve has a hyperbolic shape to itself, but when the inductive reactance dominates the circuit, the curve is non-symmetrical due to the linear response of X_L .

You may also note that if the circuit's impedance is at its minimum at resonance then consequently, the circuit's **admittance** must be at its maximum and one of the characteristics of a series resonance circuit is that admittance is very high. But this can be a bad thing because a very low value of resistance at resonance means that the resulting current flowing through the circuit may be dangerously high.

We recall from the previous tutorial about series RLC circuits that the voltage across a series combination is the phasor sum of V_R , V_L and V_C . Then if at resonance the two reactances are equal and cancelling, the two voltages representing V_L and V_C must also be opposite and equal in value thereby cancelling each other out because with pure components the phasor voltages are drawn at $+90^\circ$ and -90° respectively.

Then in a **series resonance** circuit as $V_L = -V_C$ the resulting reactive voltages are zero and all the supply voltage is dropped across the resistor. Therefore, $V_R = V_{\text{supply}}$ and it is for this reason that series resonance circuits are known as voltage resonance circuits, (as opposed to parallel resonance circuits which are current resonance circuits).

Series RLC Circuit at Resonance

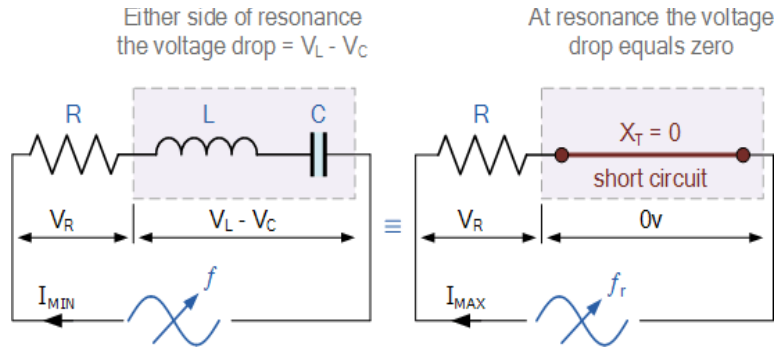

Since the current flowing through a series resonance circuit is the product of voltage divided by impedance, at resonance the impedance, Z is at its minimum value, ($=R$). Therefore, the circuit current at this frequency will be at its maximum value of V/R as shown below.

Series Circuit Current at Resonance

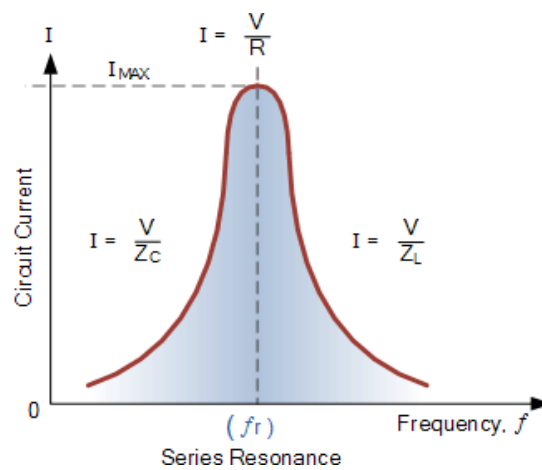

The frequency response curve of a series resonance circuit shows that the magnitude of the current is a function of frequency and plotting this onto a graph shows us that the response starts at near to zero, reaches maximum value at the resonance frequency when $I_{MAX} = I_R$ and then drops again to nearly zero as f becomes infinite. The result of this is that the magnitudes of the voltages across the inductor, L and the capacitor, C can become many times larger than the supply voltage, even at resonance but as they are equal and at opposition, they cancel each other out.

As a series resonance circuit only functions on resonant frequency, this type of circuit is also known as an **Acceptor Circuit** because at resonance, the impedance of the circuit is at its minimum so easily accepts the current whose frequency is equal to its resonant frequency.

You may also notice that as the maximum current through the circuit at resonance is limited only by the value of the resistance (a pure and real value), the source voltage and circuit current must therefore be in phase with each other at this frequency. Then the phase angle between the voltage and current of a

series resonance circuit is also a function of frequency for a fixed supply voltage and which is zero at the resonant frequency point when: V , I and V_R are all in phase with each other as shown below. Consequently, if the phase angle is zero then the power factor must therefore be unity.

Phase Angle of a Series Resonance Circuit

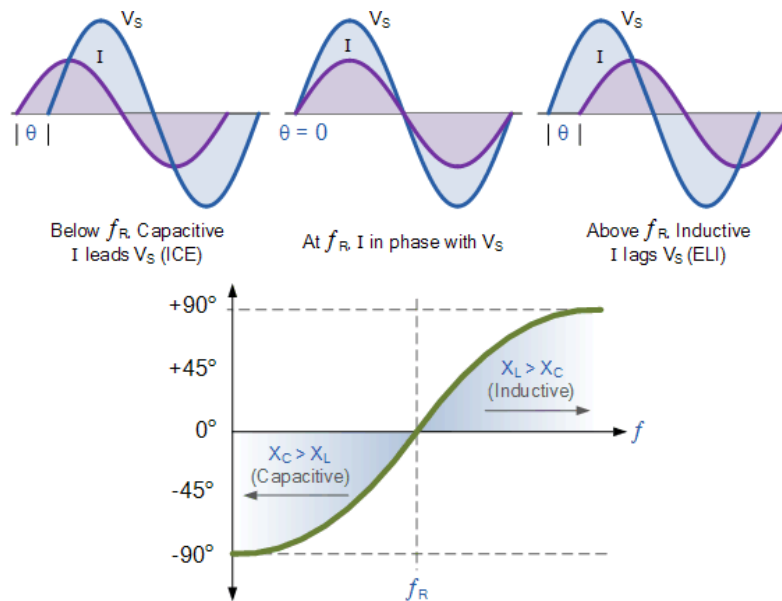

Notice also, that the phase angle is positive for frequencies above f_r and negative for frequencies below f_r and this can be proven by,

$$\arctan = \frac{X_L - X_C}{R} = 0^\circ \quad (\text{all real})$$

Bandwidth of a Series Resonance Circuit

If the series RLC circuit is driven by a variable frequency at a constant voltage, then the magnitude of the current, I is proportional to the impedance, Z , therefore at resonance the power absorbed by the circuit must be at its maximum value as $P = I^2 Z$.

If we now reduce or increase the frequency until the average power absorbed by the resistor in the series resonance circuit is half that of its maximum value at resonance, we produce two frequency points called the **half-power points** which are -3dB down from maximum, taking 0dB as the maximum current reference.

These -3dB points give us a current value that is 70.7% of its maximum resonant value which is defined as: $0.5(I^2 R) = (0.707 \times I)^2 R$. Then the point corresponding to the lower frequency at half the power is called the “lower cut-off frequency”, labelled f_L with the point corresponding to the upper frequency at

half power being called the “upper cut-off frequency”, labelled f_H . The distance between these two points, i.e. $(f_H - f_L)$ is called the **Bandwidth**, (BW) and is the range of frequencies over which at least half of the maximum power and current is provided as shown.

Bandwidth of a Series Resonance Circuit

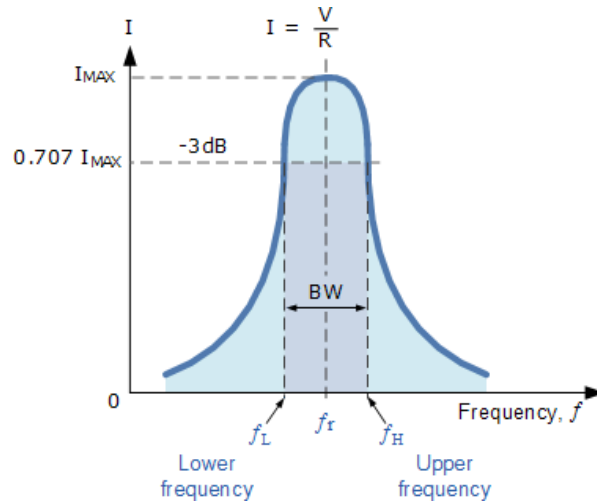

The frequency response of the circuit's current magnitude above, relates to the “sharpness” of the resonance in a series resonance circuit. The sharpness of the peak is measured quantitatively and is called the **Quality factor, Q** of the circuit. The quality factor relates the maximum or peak energy stored in the circuit (the reactance) to the energy dissipated (the resistance) during each cycle of oscillation meaning that it is a ratio of resonant frequency to bandwidth and the higher the circuit Q, the smaller the **bandwidth, $Q = f_r / BW$** .

As the bandwidth is taken between the two -3dB points, the **selectivity** of the circuit is a measure of its ability to reject any frequencies either side of these points. A more selective circuit will have a narrower bandwidth whereas a less selective circuit will have a wider bandwidth. The selectivity of a series resonance circuit can be controlled by adjusting the value of the resistance only, keeping all the other components the same, since $Q = (X_L \text{ or } X_C)/R$.

Bandwidth of a Series RLC Resonance Circuit

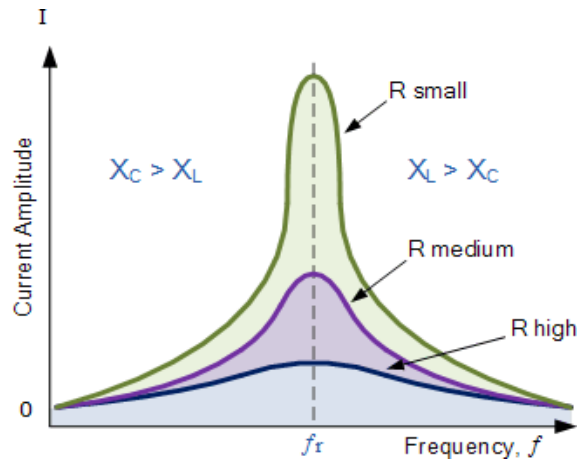

Then the relationship between resonance, bandwidth, selectivity and quality factor for a series resonance circuit being defined as:

1). Resonant Frequency, (f_r)

$$X_L = X_C \Rightarrow \omega_r L - \frac{1}{\omega_r C} = 0$$

$$\omega_r^2 = \frac{1}{LC} \quad \therefore \quad \omega_r = \frac{1}{\sqrt{LC}}$$

2). Current, (I)

at ω_r , $Z_T = \min$, $I_S = \max$

$$I_{\max} = \frac{V_{\max}}{Z} = \frac{V_{\max}}{\sqrt{R^2 + (X_L - X_C)^2}} = \frac{V_{\max}}{\sqrt{R^2 + \left(\omega_r L - \frac{1}{\omega_r C}\right)^2}}$$

3). Lower cut-off frequency, (f_l)

$$\text{At half power, } \frac{P_m}{2}, I = \frac{I_m}{\sqrt{2}} = 0.707I_m$$

$$Z = \sqrt{2}R, X = -R \text{ (capacitive)}$$

$$\omega_L = -\frac{R}{2L} + \sqrt{\left(\frac{R}{2L}\right)^2 + \frac{1}{LC}}$$

4). Upper cut-off frequency, (f_H)

$$\text{At half power, } \frac{P_m}{2}, I = \frac{I_m}{\sqrt{2}} = 0.707I_m$$

$$Z = \sqrt{2}R, X = +R \text{ (inductive)}$$

$$\omega_H = +\frac{R}{2L} + \sqrt{\left(\frac{R}{2L}\right)^2 + \frac{1}{LC}}$$

5). Bandwidth, (BW)

$$BW = \frac{f_r}{Q}, f_H - f_L, \frac{R}{L} \text{ (rads) or } \frac{R}{2\pi L} \text{ (Hz)}$$

6). Quality Factor, (Q)

$$Q = \frac{\omega_r L}{R} = \frac{X_L}{R} = \frac{1}{\omega_r C R} = \frac{X_C}{R} = \frac{1}{R} \sqrt{\frac{L}{C}}$$

Series Resonance Example No1

A series resonance network consisting of a resistor of 30Ω , a capacitor of $2\mu\text{F}$ and an inductor of 20mH is connected across a sinusoidal supply voltage which has a constant output of 9 volts at all frequencies. Calculate, the resonant frequency, the current at resonance, the voltage across the inductor and capacitor at resonance, the quality factor and the bandwidth of the circuit. Also sketch the corresponding current waveform for all frequencies.

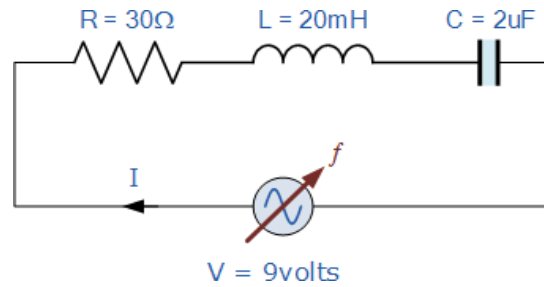

1. Resonant Frequency, f_r

$$f_r = \frac{1}{2\pi\sqrt{LC}} = \frac{1}{2\pi\sqrt{0.02 \times 2 \times 10^{-6}}} = 796\text{Hz}$$

2. Circuit Current at Resonance, I_m

$$I = \frac{V}{R} = \frac{9}{30} = 0.3\text{A or } 300\text{mA}$$

3. Inductive Reactance at Resonance, X_L

$$X_L = 2\pi fL = 2\pi \times 796 \times 0.02 = 100\Omega$$

4. Voltages across the inductor and the capacitor, V_L, V_C

$$\begin{aligned} V_L &= V_C \\ V_L &= I \times X_L = 300\text{mA} \times 100\Omega \\ V_L &= 30\text{volts} \end{aligned}$$

Note: the supply voltage may be only 9 volts, but at resonance, the reactive voltages across the capacitor, V_C and the inductor, V_L are 30 volts peak!

5. Quality factor, Q

$$Q = \frac{X_L}{R} = \frac{100}{30} = 3.33$$

6. Bandwidth, BW

$$BW = \frac{f_r}{Q} = \frac{796}{3.33} = 238\text{Hz}$$

7. The upper and lower -3dB frequency points, f_H and f_L

$$f_L = f_r - \frac{1}{2}BW = 796 - \frac{1}{2}(238) = 677\text{Hz}$$

$$f_H = f_r + \frac{1}{2}BW = 796 + \frac{1}{2}(238) = 915\text{Hz}$$

8. Current Waveform

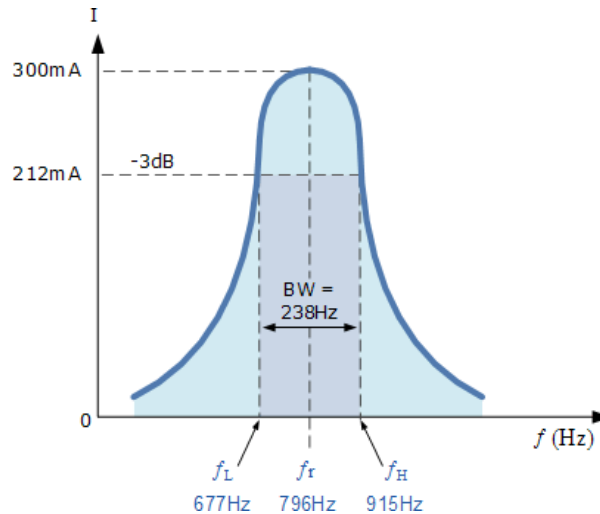

Series Resonance Example No2

A series circuit consists of a resistance of 4Ω , an inductance of 500mH and a variable capacitance connected across a 100V , 50Hz supply. Calculate the capacitance require to produce a series resonance condition, and the voltages generated across both the inductor and the capacitor at the point of resonance.

Resonant Frequency, f_r

$$X_L = 2\pi fL = 2\pi \times 50 \times 0.5 = 157.1\Omega$$

$$\text{at resonance: } X_C = X_L = 157.1\Omega$$

$$\therefore C = \frac{1}{2\pi f X_C} = \frac{1}{2\pi \cdot 50 \cdot 157.1} = 20.3\mu\text{F}$$

Voltages across the inductor and the capacitor, V_L , V_C

$$I_s = \frac{V}{R} = \frac{100}{4} = 25 \text{ Amps}$$

at Resonance: $V_L = V_C$

$$V_L = I \times X_L = 25 \times 157.1$$

Thus $V_L = 3,927.5 \text{ volts}$ or 3.9 kV

and $V_C = 3,927.5 \text{ volts}$ or 3.9 kV

Series Resonance Summary

You may have noticed that during the analysis of series resonance circuits in this tutorial, we looked at bandwidth, upper and lower frequencies, -3dB points and quality or Q-factor. All these are terms used in designing and building of Band Pass Filters (BPF) and indeed, resonance circuits are used in 3-element mains filter designs to pass all frequencies within the “passband” range while rejecting all others.

However, the main aim of this tutorial is to analyse and understand the concept of how **Series Resonance** occurs in passive RLC series circuits. Their use in RLC filter networks and designs is outside the scope of this particular tutorial, and so will not be looked at here, sorry.

- For resonance to occur in any circuit it must have at least one inductor and one capacitor.
- Resonance is the result of oscillations in a circuit as stored energy is passed from the inductor to the capacitor.
- Resonance occurs when $X_L = X_C$ and the imaginary part of the transfer function is zero.
- At resonance the impedance of the circuit is equal to the resistance value as $Z = R$.
- At low frequencies the series circuit is capacitive as: $X_C > X_L$, this gives the circuit a leading power factor.
- At high frequencies the series circuit is inductive as: $X_L > X_C$, this gives the circuit a lagging power factor.
- The high value of current at resonance produces very high values of voltage across the inductor and capacitor.
- Series resonance circuits are useful for constructing highly frequency selective filters. However, its high current and very high component voltage values can cause damage to the circuit.
- The most prominent feature of the frequency response of a resonant circuit is a sharp resonant peak in its amplitude characteristics.
- Because impedance is minimum and current is maximum, series resonance circuits are also called **Acceptor Circuits**.

11. Parallel Resonance Circuit:-

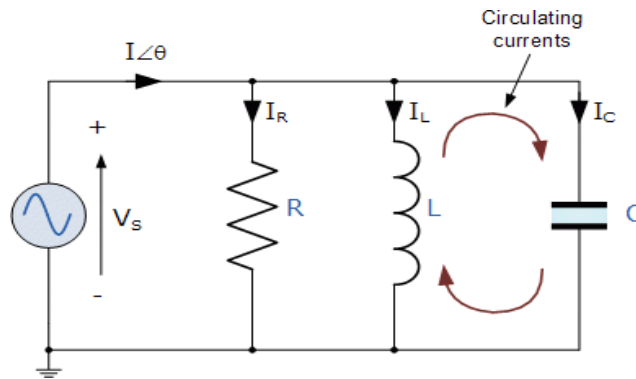

Parallel resonance occurs when the supply frequency creates zero phase difference between the supply voltage and current producing a resistive circuit

In many ways a **parallel resonance** circuit is exactly the same as the series resonance circuit we looked at in the previous tutorial. Both are 3-element networks that contain two reactive components making them a second-order circuit, both are influenced by variations in the supply frequency and both have a frequency point where their two reactive components cancel each other out influencing the characteristics of the circuit. Both circuits have a resonant frequency point.

The difference this time however, is that a parallel resonance circuit is influenced by the currents flowing through each parallel branch within the parallel LC tank circuit. A **tank circuit** is a parallel combination of L and C that is used in filter networks to either select or reject AC frequencies. Consider the parallel RLC circuit below.

Parallel RLC Circuit

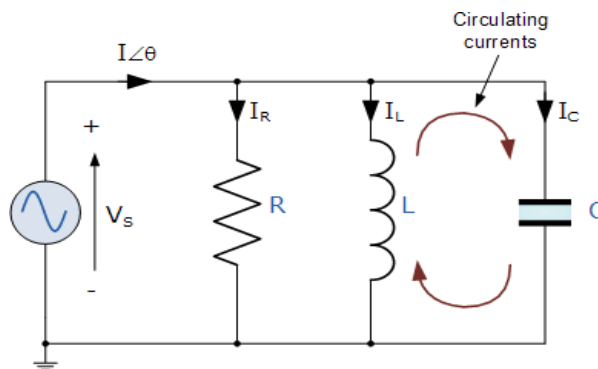

Let us define what we already know about parallel RLC circuits.

$$\text{Admittance, } Y = \frac{1}{Z} = \sqrt{G^2 + B^2}$$

$$\text{Conductance, } G = \frac{1}{R}$$

$$\text{Inductive Susceptance, } B_L = \frac{1}{2\pi fL}$$

$$\text{Capacitive Susceptance, } B_C = 2\pi fC$$

A parallel circuit containing a resistance, R, an inductance, L and a capacitance, C will produce a **parallel resonance** (also called anti-resonance) circuit when the resultant current through the parallel combination is in phase with the supply voltage. At resonance there will be a large circulating current between the inductor and the capacitor due to the energy of the oscillations, then parallel circuits produce current resonance.

A parallel resonant circuit stores the circuit energy in the magnetic field of the inductor and the electric field of the capacitor. This energy is constantly being transferred back and forth between the inductor and the capacitor which results in zero current and energy being drawn from the supply.

This is because the corresponding instantaneous values of I_L and I_C will always be equal and opposite and therefore the current drawn from the supply is the vector addition of these two currents and the current flowing in I_R .

In the solution of AC parallel resonance circuits, we know that the supply voltage is common for all branches, so this can be taken as our reference vector. Each parallel branch must be treated separately as with series circuits so that the total supply current taken by the parallel circuit is the vector addition of the individual branch currents.

Then there are two methods available to us in the analysis of parallel resonance circuits. We can calculate the current in each branch and then add together or calculate the admittance of each branch to find the total current.

We know from the previous series resonance tutorial that resonance takes place when $V_L = -V_C$ and this situation occurs when the two reactances are equal, $X_L = X_C$. The admittance of a parallel circuit is given as:

$$Y = G + B_L + B_C$$

$$Y = \frac{1}{R} + \frac{1}{j\omega L} + j\omega C$$

or

$$Y = \frac{1}{R} + \frac{1}{2\pi f L} + 2\pi f C$$

Resonance occurs when $X_L = X_C$ and the imaginary parts of Y become zero. Then:

$$X_L = X_C \Rightarrow 2\pi f L = \frac{1}{2\pi f C}$$

$$f^2 = \frac{1}{2\pi L \times 2\pi C} = \frac{1}{4\pi^2 LC}$$

$$f = \sqrt{\frac{1}{4\pi^2 LC}}$$

$$\therefore f_r = \frac{1}{2\pi\sqrt{LC}} \text{ (Hz)} \quad \text{or} \quad \omega_r = \frac{1}{\sqrt{LC}} \text{ (rads)}$$

Notice that at resonance the parallel circuit produces the same equation as for the series resonance circuit. Therefore, it makes no difference if the inductor or capacitor are connected in parallel or series.

Also, at resonance the parallel LC tank circuit acts like an open circuit with the circuit current being determined by the resistor, R only. So, the total impedance of a parallel resonance circuit at resonance becomes just the value of the resistance in the circuit and $Z = R$ as shown.

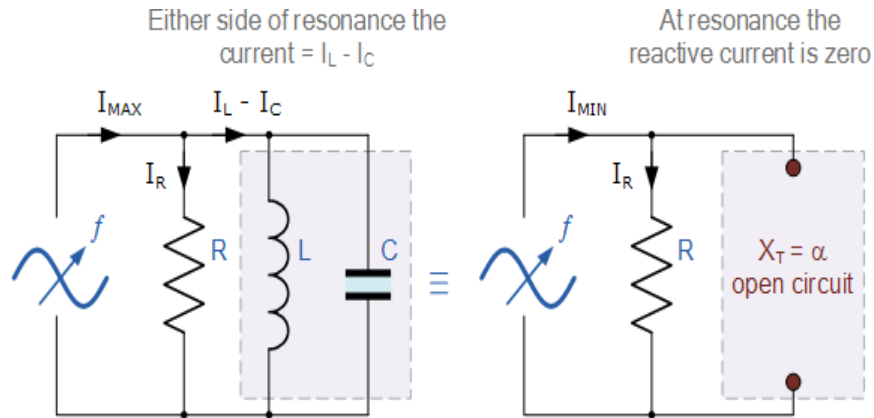

Thus, at resonance, the impedance of the parallel circuit is at its maximum value and equal to the resistance of the circuit creating a circuit condition of high resistance and low current. Also at resonance, as the impedance of the circuit is now that of resistance only, the total circuit current, I will be “in-phase” with the supply voltage, V_s .

We can change the circuit’s frequency response by changing the value of this resistance. Changing the value of R affects the amount of current that flows through the circuit at resonance, if both L and C remain constant. Then the impedance of the circuit at resonance $Z = R_{MAX}$ is called the “dynamic impedance” of the circuit.

Impedance in a Parallel Resonance Circuit

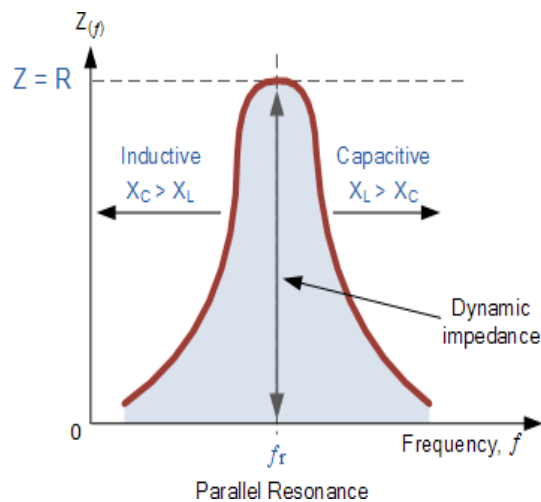

Note that if the parallel circuits impedance is at its maximum at resonance then consequently, the circuits **admittance** must be at its minimum and one of the characteristics of a parallel resonance circuit is that admittance is very low limiting the circuits current. Unlike the series resonance circuit, the resistor in a parallel resonance circuit has a damping effect on the circuit's bandwidth making the circuit less selective.

Also, since the circuit current is constant for any value of impedance, Z , the voltage across a parallel resonance circuit will have the same shape as the total impedance and for a parallel circuit the voltage waveform is generally taken from across the capacitor.

We now know that at the resonant frequency, f_r the admittance of the circuit is at its minimum and is equal to the conductance, G given by $1/R$ because in a parallel resonance circuit the imaginary part of admittance, i.e., the susceptance, B is zero because $B_L = B_C$ as shown.

Susceptance at Resonance

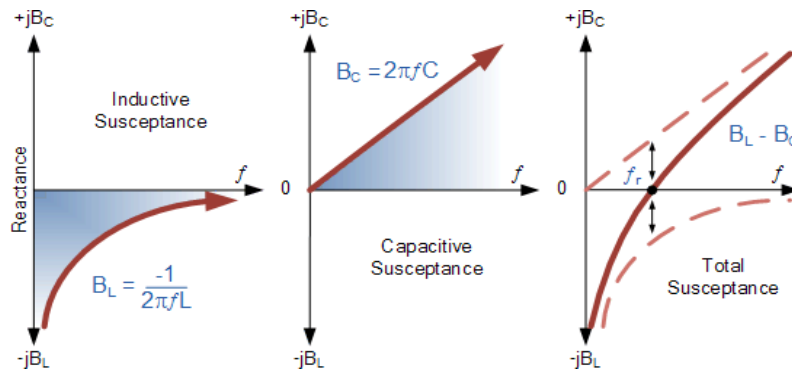

From above, the *inductive susceptance*, B_L is inversely proportional to the frequency as represented by the hyperbolic curve. The *capacitive susceptance*, B_C is directly proportional to the frequency and is therefore represented by a straight line. The final curve shows the plot of total susceptance of the parallel resonance circuit versus the frequency and is the difference between the two susceptance's.

Then we can see that at the resonant frequency point where it crosses the horizontal axis the total circuit susceptance is zero. Below the resonant frequency point, the inductive susceptance dominates the circuit producing a “lagging” power factor, whereas above the resonant frequency point the capacitive susceptance dominates producing a “leading” power factor.

So, at the resonant frequency, f_r the current drawn from the supply must be “in-phase” with the applied voltage as effectively there is only the resistance present in the parallel circuit, so the power factor becomes one or unity, ($\theta = 0^\circ$).

Also, as the impedance of a parallel circuit changes with frequency, this makes the circuit impedance “dynamic” with the current at resonance being in-phase with the voltage since the impedance of the circuit acts as a resistance. Then we have seen that the impedance of a parallel circuit at resonance is equivalent to the value of the resistance and this value must, therefore represent the maximum dynamic impedance (Z_d) of the circuit as shown.

$$Z_d = \frac{L}{RC}$$

Current in a Parallel Resonance Circuit

As the total susceptance is zero at the resonant frequency, the admittance is at its minimum and is equal to the conductance, G. Therefore, at resonance the current flowing through the circuit must also be at its minimum as the inductive and capacitive branch currents are equal ($I_L = I_C$) and are 180° out of phase.

We remember that the total current flowing in a parallel RLC circuit is equal to the vector sum of the individual branch currents and for a given frequency is calculated as:

$$I_R = \frac{V}{R}$$

$$I_L = \frac{V}{X_L} = \frac{V}{2\pi fL}$$

$$I_C = \frac{V}{X_C} = V \cdot 2\pi fC$$

Therefore, $I_T = \text{vector sum of } (I_R + I_L + I_C)$

$$I_T = \sqrt{I_R^2 + (I_L + I_C)^2}$$

At resonance, currents I_L and I_C are equal and cancelling giving a net reactive current equal to zero. Then at resonance the above equation becomes.

$$I_T = \sqrt{I_R^2 + 0^2} = I_R$$

Since the current flowing through a parallel resonance circuit is the product of voltage divided by impedance, at resonance the impedance, Z is at its maximum value, ($=R$). Therefore, the circuit current at this frequency will be at its minimum value of V/R and the graph of current against frequency for a parallel resonance circuit is given as.

Parallel Circuit Current at Resonance

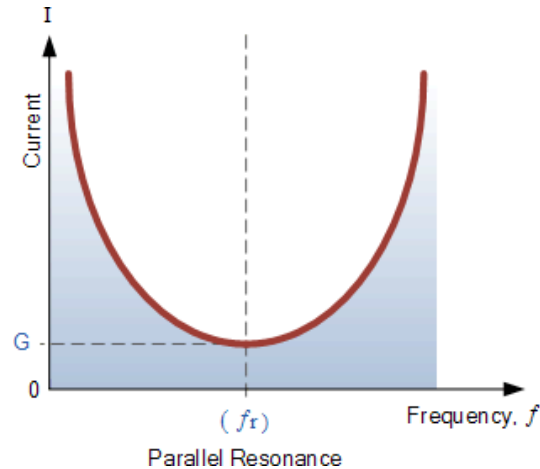

The frequency response curve of a parallel resonance circuit shows that the magnitude of the current is a function of frequency and plotting this onto a graph shows us that the response starts at its maximum value, reaches its minimum value at the resonance frequency when $I_{\text{MIN}} = I_R$ and then increases again to maximum as f becomes infinite.

The result of this is that the magnitude of the current flowing through the inductor, L and the capacitor, C tank circuit can become many times larger than the supply current, even at resonance but as they are equal and at opposition (180° out-of-phase) they effectively cancel each other out.

As a parallel resonance circuit only functions on resonant frequency, this type of circuit is also known as a **Rejecter Circuit** because at resonance, the impedance of the circuit is at its maximum thereby suppressing or rejecting the current whose frequency is equal to its resonant frequency. The effect of resonance in a parallel circuit is also called “current resonance”.

The calculations and graphs used above for defining a parallel resonance circuit are similar to those we used for a series circuit. However, the characteristics and graphs drawn for a parallel circuit are exactly opposite to that of series circuits with the parallel circuit's maximum and minimum impedance, current and magnification being reversed. Which is why a parallel resonance circuit is also called an **Anti-resonance** circuit.

Bandwidth & Selectivity of a Parallel Resonance Circuit

The bandwidth of a parallel resonance circuit is defined in exactly the same way as for the series resonance circuit. The upper and lower cut-off frequencies given as: f_{upper} and f_{lower} respectively denote the half-power frequencies where the power dissipated in the circuit is half of the full power dissipated at the resonant frequency $0.5(I^2 R)$ which gives us the same -3dB points at a current value that is equal to 70.7% of its maximum resonant value, $(0.707 \times I)^2 R$

As with the series circuit, if the resonant frequency remains constant, an increase in the quality factor, Q will cause a decrease in the bandwidth and likewise, a decrease in the quality factor will cause an increase in the bandwidth as defined by:

$$BW = f_r / Q \text{ or } BW = f_{\text{upper}} - f_{\text{lower}}$$

Also changing the ratio between the inductor, L and the capacitor, C, or the value of the resistance, R the bandwidth and therefore the frequency response of the circuit will be changed for a fixed resonant frequency. This technique is used extensively in tuning circuits for radio and television transmitters and receivers.

The selectivity or **Q-factor** for a parallel resonance circuit is generally defined as the ratio of the circulating branch currents to the supply current and is given as:

$$\text{Quality Factor, } Q = \frac{R}{2\pi fL} = 2\pi fCR = R\sqrt{\frac{C}{L}}$$

Note that the Q-factor of a parallel resonance circuit is the inverse of the expression for the Q-factor of the series circuit. Also in series resonance circuits the Q-factor gives the voltage magnification of the circuit, whereas in a parallel circuit it gives the current magnification.

Bandwidth of a Parallel Resonance Circuit

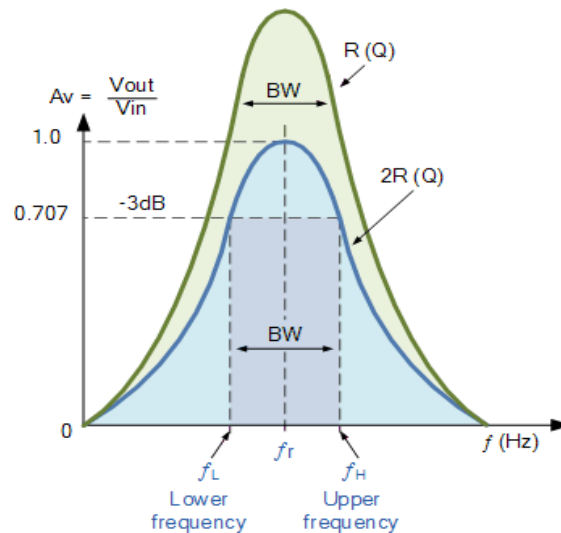

Parallel Resonance Example No1

A parallel resonance network consisting of a resistor of 60Ω , a capacitor of $120\mu\text{F}$ and an inductor of 200mH is connected across a sinusoidal supply voltage which has a constant output of 100 volts at all frequencies. Calculate, the resonant frequency, the quality factor and the bandwidth of the circuit, the circuit current at resonance and current magnification.

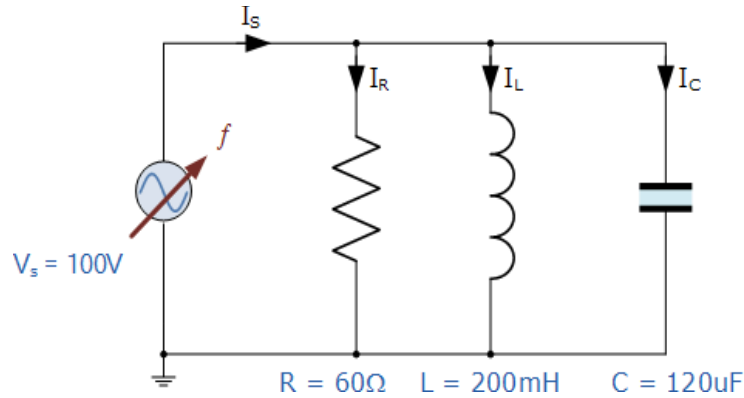

1. Resonant Frequency, f_r

$$f_r = \frac{1}{2\pi\sqrt{LC}} = \frac{1}{2\pi\sqrt{0.2 \cdot 120 \cdot 10^{-6}}} = 32.5\text{Hz}$$

2. Inductive Reactance at Resonance, X_L

$$X_L = 2\pi fL = 2\pi \cdot 32.5 \cdot 0.2 = 40.8\Omega$$

3. Quality factor, Q

$$Q = \frac{R}{X_L} = \frac{R}{2\pi fL} = \frac{60}{40.8} = 1.47$$

4. Bandwidth, BW

$$BW = \frac{f_r}{Q} = \frac{32.5}{1.47} = 22\text{Hz}$$

5. The upper and lower -3dB frequency points, f_H and f_L

$$f_L = f_r - \frac{1}{2}BW = 32.5 - \frac{1}{2}(22) = 21.5\text{Hz}$$

$$f_H = f_r + \frac{1}{2}BW = 32.5 + \frac{1}{2}(22) = 43.5\text{Hz}$$

6. Circuit Current at Resonance, I_T

At resonance the dynamic impedance of the circuit is equal to R

$$I_T = I_R = \frac{V}{R} = \frac{100}{60} = 1.67\text{A}$$

7. Current Magnification, I_{mag}

$$I_{\text{MAG}} = Q \times I_T = 1.47 \times 1.67 = 2.45\text{A}$$

Note that the current drawn from the supply at resonance (the resistive current) is only 1.67 amps, while the current flowing around the LC tank circuit is larger at 2.45 amps. We can check this value by calculating the current flowing through the inductor (or capacitor) at resonance.

$$I_L = \frac{V}{X_L} = \frac{V}{2\pi fL} = \frac{100}{2\pi \cdot 32.5 \cdot 0.2} = 2.45A$$

Parallel Resonance Tutorial Summary

We have seen that **Parallel Resonance** circuits are similar to series resonance circuits. Resonance occurs in a parallel RLC circuit when the total circuit current is “in-phase” with the supply voltage as the two reactive components cancel each other out.

At resonance the admittance of the circuit is at its minimum and is equal to the conductance of the circuit. Also, at resonance the current drawn from the supply is also at its minimum and is determined by the value of the parallel resistance.

The equation used to calculate the resonant frequency point is the same for the previous series circuit. However, while the use of either pure or impure components in the series RLC circuit does not affect the calculation of the resonance frequency, but in a parallel RLC circuit it does.

In this tutorial about parallel resonance, we have assumed that the two reactive components are purely inductive and purely capacitive with zero impedance. However, in reality, the inductor will contain some amount resistance in series, R_s with its inductive coil, since inductors (and solenoids) are wound coils of wire, usually made from copper, wrapped around a central core.

Therefore, the basic equation above for calculating the parallel resonant frequency, f_r of a pure parallel resonance circuit will need to be modified slightly to take account of the impure inductor having a series resistance.

Resonant Frequency using Impure Inductor

$$f_R = \frac{1}{2\pi} \sqrt{\frac{1}{LC} - \left(\frac{R_S}{L}\right)^2}$$

Where: L is the inductance of the coil, C is the parallel capacitance and R_s is the DC resistive value of the coil.

12. Reactive Power:-

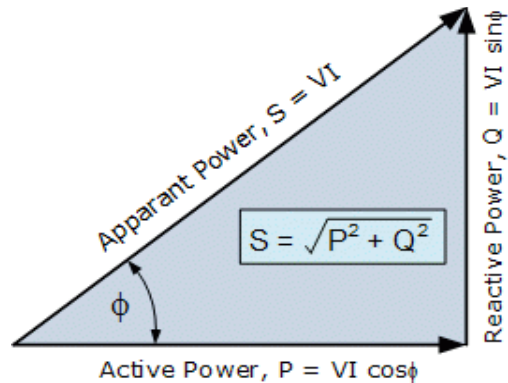

Reactive Power can best be described as the quantity of “unused” power that is developed by reactive components in an AC circuit or system.

In a DC circuit, the product of “volts x amps” gives the power consumed in watts by the circuit. However, while this formula is also true for purely resistive AC circuits, the situation is slightly more complex in an AC circuits containing reactive components as this volt-amp product can change with frequency.

In an AC circuit, the product of voltage and current is expressed as volt-amperes (VA) or kilo volt-amperes (kVA) and is known as *Apparent power*, symbol S. In a non-inductive purely resistive circuit such as heaters, irons, kettles and filament bulbs etc, their reactance is practically zero, so the impedance of the circuit is composed almost entirely of just resistance.

For an AC resistive circuit, the current and voltage are in-phase and the power at any instant can be found by multiplying the voltage by the current at that instant, and because of this “in-phase” relationship, the rms values can be used to find the equivalent DC power or heating effect.

However, if the circuit contains reactive components, the voltage and current waveforms will be “out-of-phase” by some amount determined by the circuits phase angle. If the phase angle between the voltage and the current is at its maximum of 90°, the volt-amp product will have equal positive and negative values.

In other words, the reactive circuit returns as much power to the supply as it consumes resulting in the average power consumed by the circuit being zero, as the same amount of energy keeps flowing alternately from source to the load and back from load to source.

Since we have a voltage and a current but no power dissipated, the expression of $P = IV$ (rms) is no longer valid and it therefore follows that the volt-amp product in an AC circuit does not necessarily give the power consumed. Then in order to determine the “real power”, also called *Active power*, symbol P consumed by an AC circuit, we need to account for not only the volt-amp product but also the phase angle difference between the voltage and the current waveforms given by the equation: $VI \cdot \cos\Phi$.

Then we can write the relationship between the apparent power and active or real power as:

$$\text{Active Power, (P)} = \text{Apparant Power, (S)} \times \text{Power Factor, (pf)}$$

$$\text{Power Factor, (pf)} = \frac{\text{Active Power, (P) in Watts}}{\text{Apparant Power, (S) in volt - amps}}$$

Note that power factor (PF) is defined as the ratio between the active power in watts and the apparent power in volt-amperes and indicates how effectively electrical power is being used. In a non-inductive resistive AC circuit, the active power will be equal to the apparent power as the fraction of P/S becomes equal to one or unity. A circuits power factor can be expressed either as a decimal value or as a percentage.

But as well as the active and apparent powers in AC circuits, there is also another power component that is present whenever there is a phase angle. This component is called **Reactive Power** (sometimes referred to as imaginary power) and is expressed in a unit called “volt-amperes reactive”, (VAr), symbol Q and is given by the equation: $VI.\sin\Phi$.

Reactive power, or VAr, is not really power at all but represents the product of volts and amperes that are out-of-phase with each other. Reactive power is the portion of electricity that helps establish and sustain the electric and magnetic fields required by alternating current equipment. The amount of reactive power present in an AC circuit will depend upon the phase shift or phase angle between the voltage and the current and just like active power, reactive power is positive when it is “supplied” and negative when it is “consumed”.

Reactive power is used by most types of electrical equipment that uses a magnetic field, such as motors, generators and transformers. It is also required to supply the reactive losses on overhead power transmission lines.

The relationship of the three elements of power, active power, (watts) apparent power, (VA) and reactive power, (VAr) in an AC circuit can be represented by the three sides of right-angled triangle. This representation is called a **Power Triangle** as shown:

Power in an AC Circuit

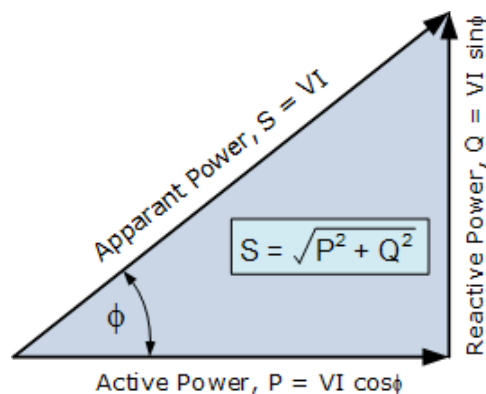

From the above power triangle, we can see that AC circuits supply or consume two kinds of power: active power and reactive power. Also, active power is never negative, whereas reactive power can be either positive or negative in value so it is always advantageous to reduce reactive power in order to improve system efficiency.

The main advantage of using AC electrical power distribution is that the supply voltage level can be changed using transformers, but transformers and induction motors of household appliances, air conditioners and industrial equipment all consume reactive power which takes up space on the transmission lines since larger conductors and transformers are required to handle the larger currents which you need to pay for.

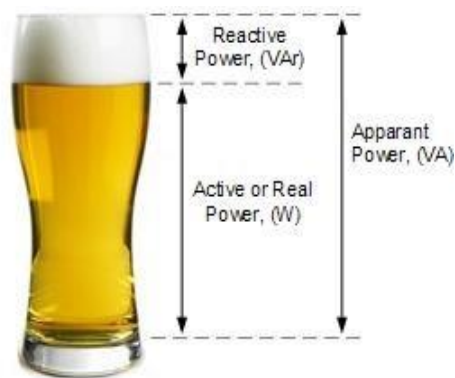

**Reactive Power Analogy
Using a Pint of Beer**

In many ways, reactive power can be thought of like the foam head on a pint or glass of beer. You pay the barman for a full glass of beer but you only drink the actual liquid beer itself which, on many occasions, is always less than a full glass.

This is because the head (or froth) of the beer takes up additional wasted space in the glass leaving less room for the real liquid beer that you consume, and the same idea is true in many ways for reactive power.

But for many industrial power applications, reactive power is often useful for an electrical circuit to have. While the real or active power is the energy supplied to run a motor, heat a home, or illuminate an electric light bulb, reactive power provides the important function of regulating the voltage thereby helping to move power effectively through the utility grid and transmission lines to where it is required by the load.

While reducing reactive power to help improve the power factor and system efficiency is a good thing, one of the disadvantages of reactive power is that a sufficient quantity of it is required to control the voltage and overcome the losses in a transmission network. This is because if the electrical network voltage is not high enough, active power cannot be supplied. But having too much reactive power

flowing around in the network can cause excess heating (I^2R losses) and undesirable voltage drops and loss of power along the transmission lines.

Power Factor Correction of Reactive Power

One way to avoid reactive power charges, is to install power factor correction capacitors. Normally residential customers are charged only for the active power consumed in kilo-watt hours (kWhr) because nearly all residential and single-phase power factor values are essentially the same due to power factor correction capacitors being built into most domestic appliances by the manufacturer.

Industrial customers, on the other hand, which use 3-phase supplies have widely different power factors, and for this reason, the electrical utility may have to take the power factors of these industrial customers into account paying a penalty if their power factor drops below a prescribed value because it costs the utility companies more to supply industrial customers since larger conductors, larger transformers, larger switchgear, etc, is required to handle the larger currents.

Generally, for a load with a power factor of less than 0.95 more reactive power is required. For a load with a power factor value higher than 0.95 is considered good as the power is being consumed more effectively, and a load with a power factor of 1.0 or unity is considered perfect and does not use any reactive power.

Then we have seen that “apparent power” is a combination of both “reactive power” and “active power”. Active or real power is a result of a circuit containing resistive components only, while reactive power results from a circuit containing either capacitive and inductive components. Almost all AC circuits will contain a combination of these R, L and C components.

Since reactive power takes away from the active power, it must be considered in an electrical system to ensure that the apparent power supplied is sufficient to supply the load. This is a critical aspect of understanding AC power sources because the power source must be capable of supplying the necessary volt-amp (VA) power for any given load.

13. Power in AC Circuits: -

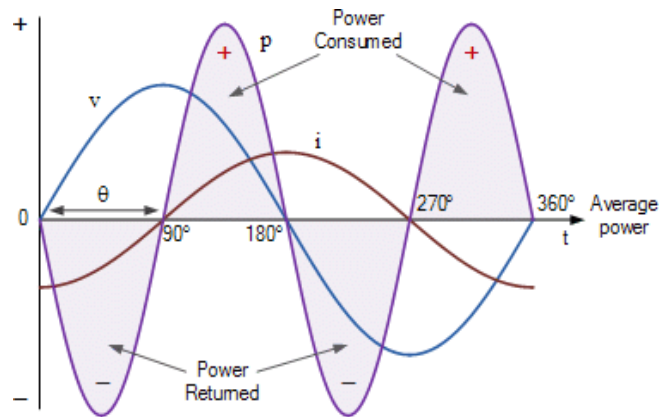

Electrical power consumed by a resistance in an AC circuit is different to the power consumed by a reactance as reactances do not dissipate energy

In a DC circuit, the power consumed is simply the product of the DC voltage times the DC current, given in watts. However, for AC circuits with reactive components we have to calculate the consumed power differently.

Electrical power is the “rate” at which energy is being consumed in a circuit and as such all electrical and electronic components and devices have a limit to the amount of electrical power that they can safely handle. For example, a 1/4 watt resistor or a 20 watt amplifier.

Electrical power can be time-varying either as a DC quantity or as an AC quantity. The amount of power in a circuit at any instant of time is called the *instantaneous power* and is given by the well-known relationship of power equals volts times amps ($P = V \times I$). So one watt (which is the rate of expending energy at one joule per second) will be equal to the volt-ampere product of one volt times one ampere.

Then the power absorbed or supplied by a circuit element is the product of the voltage, V across the element, and the current, I flowing through it. So if we had a DC circuit with a resistance of “ R ” ohms, the power dissipated by the resistor in watts is given by any of the following generalized formulas:

Electrical Power

$$P = V \times I = \frac{V^2}{R} = I^2 \times R \text{ (watts)}$$

Where: V is the dc voltage, I is the dc current and R is the value of the resistance.

So power within an electrical circuit is only present when both the voltage and current are present, that is no open-circuit or closed-circuit conditions. Consider the following simple example of a standard resistive dc circuit:

DC Resistive Circuit

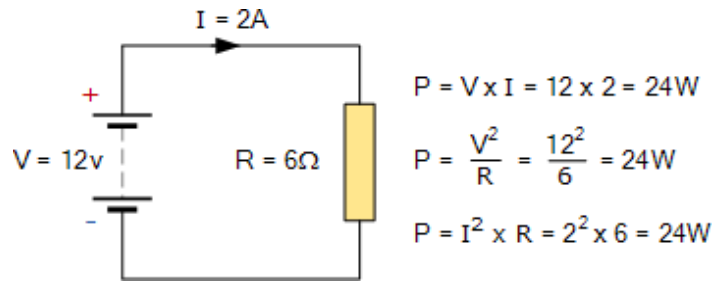

Electrical Power in an AC Circuit

In a DC circuit, the voltages and currents are generally constant, that is not varying with time as there is no sinusoidal waveform associated with the supply. However in an AC circuit, the instantaneous values of the voltage, current and therefore power are constantly changing being influenced by the supply. So we can not calculate the power in AC circuits in the same manner as we can in DC circuits, but we can still say that power (p) is equal to the voltage (v) times the amperes (i).

Another important point is that AC circuits contain reactance, so there is a power component as a result of the magnetic and/or electric fields created by the components. The result is that unlike a purely resistive component, this power is stored and then returned back to the supply as the sinusoidal waveform goes through one complete periodic cycle.

Thus, the average power absorbed by a circuit is the sum of the power stored and the power returned over one complete cycle. So a circuit's average power consumption will be the average of the instantaneous power over one full cycle with the instantaneous power, p defined as the multiplication of the instantaneous voltage, v by the instantaneous current, i . Note that as the sine function is periodic and continuous, the average power given over all time will be exactly the same as the average power given over a single cycle.

Let us assume that the waveforms of the voltage and current are both sinusoidal, so we recall that:

Sinusoidal Voltage Waveform

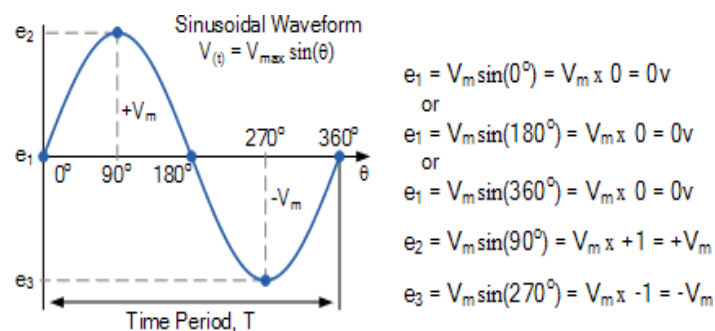

As the instantaneous power is the power at any instant of time, then:

$$p = v \times i$$

where:

$$v = V_m \sin(\omega t + \theta_v)$$

$$i = I_m \sin(\omega t + \theta_i)$$

$$p = [V_m \sin(\omega t + \theta_v)] \times [I_m \sin(\omega t + \theta_i)]$$

$$\therefore p = V_m I_m [\sin(\omega t + \theta_v) \sin(\omega t + \theta_i)]$$

Applying the trigonometric product-to-sum identity of:

$$\sin A \sin B = \frac{1}{2} [\cos(A - B) - \cos(A + B)]$$

and $\theta = \theta_v - \theta_i$ (the phase difference between the voltage and the current waveforms) into the above equation gives:

$$p = \frac{V_m I_m}{2} [\cos \theta - \cos(2\omega t + \theta)]$$

$$\text{As: } \frac{V_m I_m}{2} = \frac{V_m}{\sqrt{2}} \times \frac{I_m}{\sqrt{2}} = V_{\text{rms}} \times I_{\text{rms}} \text{ (W)}$$

Where **V** and **I** are the root-mean-squared (rms) values of the sinusoidal waveforms, v and i respectively, and θ is the phase difference between the two waveforms. Therefore, we can express the instantaneous power as being:

Instantaneous AC Power Equation

$$p = VI \cos \theta - VI \cos(2\omega t + \theta)$$

This equation shows us that the instantaneous AC power has two different parts and is therefore the sum of these two terms. The second term is a time varying sinusoid whose frequency is equal to twice the angular frequency of the supply due to the 2ω part of the term. The first term however is a constant whose value depends only on the phase difference, θ between the voltage, (V) and the current, (I).

As the instantaneous power is constantly changing with the profile of the sinusoid over time, this makes it difficult to measure. It is therefore more convenient, and easier on the maths to use the average or

mean value of the power. So over a fixed number of cycles, the average value of the instantaneous power of the sinusoid is given simply as:

$$p = V \times I \cos \theta$$

Where **V** and **I** are the sinusoids rms values, and **θ** (Theta) is the phase angle between the voltage and the current. The units of power are in watts (W).

The AC Power dissipated in a circuit can also be found from the impedance, (Z) of the circuit using the voltage, V_{rms} or the current, I_{rms} flowing through the circuit as shown.

$$Z = \sqrt{R^2 + (X_L - X_C)^2}$$

$$\theta = \cos^{-1} = \frac{R}{Z}, \text{ or } \sin^{-1} = \frac{X_L}{Z}, \text{ or } \tan^{-1} = \frac{X_L}{R}$$

$$\therefore P = \frac{V^2}{Z} \cos(\theta) \text{ or } P = I^2 Z \cos(\theta)$$

AC Power Example No1

The voltage and current values of a 50Hz sinusoidal supply are given as: $v_t = 240 \sin(\omega t + 60^\circ)$ Volts and $i_t = 5 \sin(\omega t - 10^\circ)$ Amps respectively. Find the values of the instantaneous power and the average power absorbed by the circuit.

From above, the instantaneous power absorbed by the circuit is given as:

$$p = v \times i = 240 \left(\sin \omega t + 60^\circ \right) \times 5 \left(\sin \omega t - 10^\circ \right)$$

$$p = 240 \times 5 \left[\sin \left(314.2t + 60^\circ \right) \sin \left(314.2t - 10^\circ \right) \right]$$

$$\therefore p = 1200 \left[\sin \left(314.2t + 60^\circ \right) \sin \left(314.2t - 10^\circ \right) \right]$$

Applying the trigonometric identity rule from above gives:

$$\sin A \sin B = \frac{1}{2} [\cos(A-B) - \cos(A+B)]$$

then:

$$p = \frac{V_m I_m}{2} [\cos \theta - \cos(2\omega t + \theta)]$$

$$p = \frac{240 \times 5}{2} [\cos(60 - (-10)) - \cos(2 \times 314.2t + 60 + (-10))]$$

$$\therefore p = 600 [\cos(70^\circ) - \cos(628.4t + 50^\circ)]$$

or

$$p_{(t)} = 205.2 - 600 [\cos(628.4t + 50^\circ)] \text{ Watts}$$

The average power is then calculated as:

$$P_{(avg)} = \frac{V_m I_m}{2} \cos(\theta_v - \theta_i)$$

$$P_{(avg)} = \frac{240 \times 5}{2} \cos(60^\circ - (-10^\circ))$$

$$\therefore P_{(avg)} = 600 \cos(70^\circ) = 205.2 \text{ Watts}$$

You may have noticed that the average power value of 205.2 watts is also the first term value of the instantaneous power $p_{(t)}$ as this first term constant value is the average or mean rate of energy change between the source and load.

AC Power in a Purely Resistive Circuit

We have seen thus far, that in a dc circuit, power is equal to the product of voltage and current and this relationship is also true for a purely resistive AC circuit. Resistors are electrical devices that consume energy and the power in a resistor is given by $p = VI = I^2R = V^2/R$. This power is always positive.

Consider the following purely resistive (that is infinite capacitance, $C = \infty$ and zero inductance, $L = 0$) circuit with a resistor connected to an AC supply, as shown.

Purely Resistive Circuit

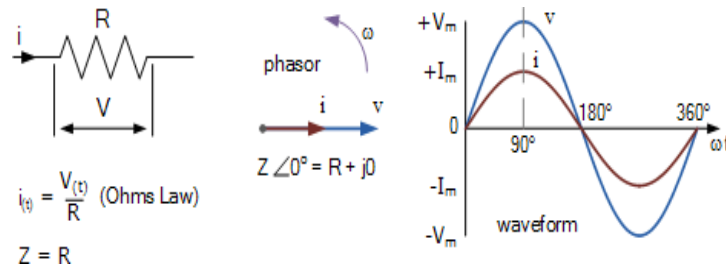

When a pure resistor is connected to a sinusoidal voltage supply, the current flowing through the resistor will vary in proportion to the supply voltage, that is the voltage and current waveforms are “in-phase” with each other. Since the phase difference between the voltage waveform and the current waveform is 0° , the phase angle resulting in $\cos 0^\circ$ will be equal to 1.

Then the electrical power consumed by the resistor is given by:

Electrical Power in a Pure Resistor

$$P = V \times I \cos\theta$$

$$\cos(0^\circ) = 1$$

$$\therefore P = V \times I \times 1 = V \times I \text{ (watts, W)}$$

As the voltage and current waveforms are in-phase, that is both waveforms reach their peak values at the same time, and also pass through zero at the same time, the power equation above reduces down to just: $V \times I$. Therefore, the power at any instant can be found by multiplying together the two waveforms to give the volt-ampere product. This is called the “Real Power”, (P) measured in watts, (W), Kilowatt (kW), Megawatt (MW), etc.

AC Power Waveforms for a Pure Resistor

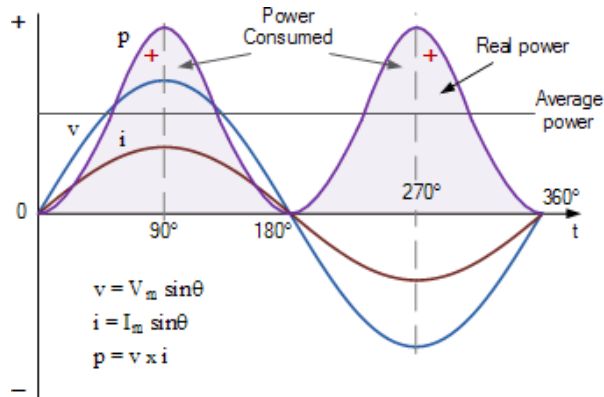

The diagram shows the voltage, current and corresponding power waveforms. As the voltage and current waveforms are both in-phase, during the positive half-cycle, when the voltage is positive, the current is also positive so the power is positive, as a positive time a positive equal a positive. During the negative half-cycle, the voltage is negative, so too is the current resulting in the power being positive, as a negative time a negative equal a positive.

Then in a purely resistive circuit, electrical power is consumed ALL the time that current is flowing through the resistor and is given as: $P = V \cdot I = I^2 R$ watts. Note that both V and I can be their rms values where: $V = I \cdot R$ and $I = V/R$

AC Power in a Purely Inductive Circuit

In a purely inductive (that is infinite capacitance, $C = \infty$ and zero resistance, $R = 0$) circuit of L Henries, the voltage and current waveforms are not in-phase. Whenever a changing voltage is applied to a purely inductive coil, a “back” emf is produced by the coil due to its self-inductance. This self-inductance opposes and limits any changes to the current flowing in the coil.

The effects of this back emf is that the current cannot increase immediately through the coil in-phase with the applied voltage causing the current waveform to reach its peak or maximum value some time after that of the voltage. The result is that in a purely inductive circuit, the current always “lags” (ELI) behind the voltage by 90° ($\pi/2$) as shown.

Purely Inductive Circuit

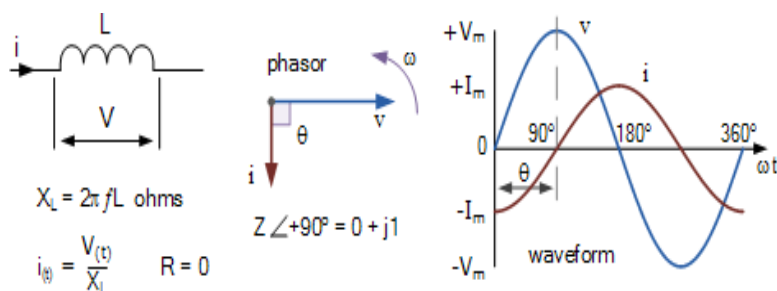

The waveforms above show us the instantaneous voltage and instantaneous current across a purely inductive coil as a function of time. Maximum current, I_{\max} occurs at one full quarter of a cycle (90°) after the maximum (peak) value of the voltage. Here the current is shown with its negative maximum value at the start of the voltage cycle and passes through zero increasing to its positive maximum value when the voltage waveform is at its maximum value at 90° .

Thus, as the voltage and current waveforms are no longer rising and falling together, but instead a phase shift of 90° ($\pi/2$) is introduced in the coil, then the voltage and current waveforms are “out-of-phase” with each other as the voltage leads the current by 90° . Since the phase difference between the voltage waveform and the current waveform is 90° , then the phase angle resulting in $\cos 90^\circ = 0$.

Therefore, the electrical power stored by a pure inductor, Q_L is given by:

Real Power in a Pure Inductor

$$P = V \times I \cos\theta$$

$$\cos(90^\circ) = 0$$

$$\therefore P = V \times I \times 0 = 0 \text{ (watts)}$$

Clearly then, a pure inductor does not consume or dissipate any real or true power, but as we have both voltage and current the use of $\cos(\theta)$ in the expression: $P = V \times I \times \cos(\theta)$ for a pure inductor is no longer valid. The product of the current and the voltage in this case is imaginary power, commonly called “Reactive Power”, (Q) measured in volt-amperes reactive, (VAr), Kilo-voltamperes reactive (KVAR), etc.

Voltamperes reactive, VAr should not be confused with watts, (W) which is used for real power. VAr represents the product of the volts and amperes that are 90° out-of-phase with each other. To identify the reactive average power mathematically, the sine function is used. Then the equation for the average reactive power in an inductor becomes:

Reactive Power in a Pure Inductor

$$Q_L = V \times I \sin\theta$$

$$\sin(+90^\circ) = +1$$

$$\therefore Q_L = V \times I \times +1 = V \times I \text{ (VAr)}$$

Like real power (P), reactive power, (Q) also depends on voltage and current, but also the phase angle between them. It is therefore the product of the applied voltage and the component part of the current which is 90° out-of-phase with the voltage as shown.

AC Power Waveforms for a Pure Inductor

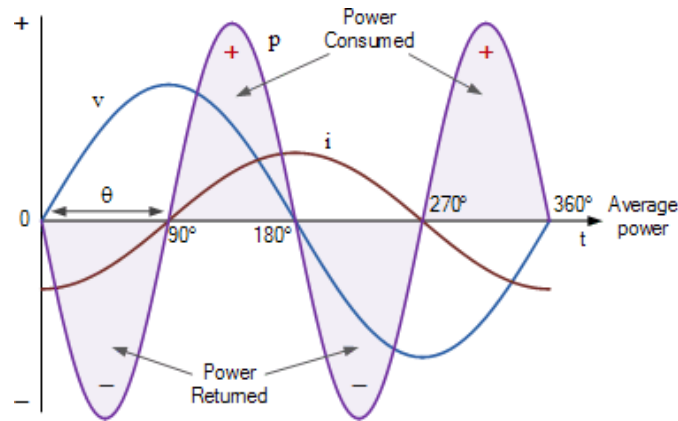

In the positive half of the voltage waveform between the angle of 0° and 90° , the inductor current is negative while the supply voltage is positive. Therefore, the volts and ampere product give a negative power as a negative time a positive equal a negative. Between 90° and 180° , both current and voltage waveforms are positive in value resulting in positive power. This positive power indicates that the coil is consuming electrical energy from the supply.

In the negative half of the voltage waveform between 180° and 270° , there is a negative voltage and positive current indicating a negative power. This negative power indicates that the coil is returning the stored electrical energy back to the supply. Between 270° and 360° , both the inductors current and the supply voltage are both negative resulting in a period of positive power.

Then during one full-cycle of the voltage waveform we have two identical positive and negative pulses of power whose average value is zero so no real power is used up since the power alternately flows to and from the source. This means then that the total power taken by a pure inductor over one full-cycle is zero, so an inductors reactive power does not perform any real work.

AC Power in a Purely Capacitive Circuit

A purely capacitive (that is zero inductance, $L = 0$ and infinite resistance, $R = \infty$) circuit of C Farads, has the property of delaying changes in the voltage across it. Capacitors store electrical energy in the form of an electric field within the dielectric so a pure capacitor does not dissipate any energy but instead stores it.

In a purely capacitive circuit, the voltage cannot increase in-phase with the current as it needs to “charge-up” the capacitors plates first. This causes the voltage waveform to reach its peak or maximum

value sometime after that of the current. The result is that in a purely capacitive circuit, the current always “leads” (ICE) the voltage by 90° ($\omega/2$) as shown.

Purely Capacitive Circuit

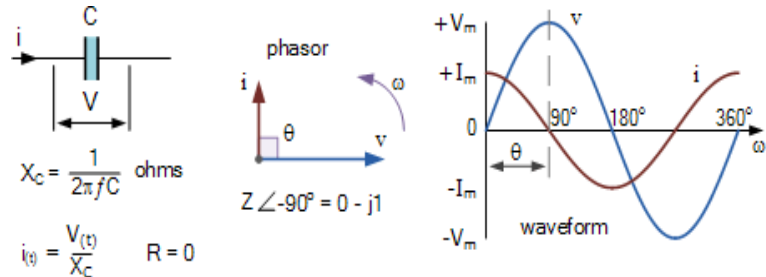

The waveform shows us the voltage and current across a pure capacitor as a function of time. Maximum current, I_m occurs a one full quarter of a cycle (90°) before the maximum (peak) value of the voltage. Here the current is shown with its positive maximum value at the start of the voltage cycle and passes through zero, decreasing to its negative maximum value when the voltage waveform is at its maximum value at 90° . The opposite phase shift to the purely inductive circuit.

Thus, for a purely capacitive circuit, the phase angle $\theta = -90^\circ$ and the equation for the average reactive power in a capacitor becomes:

Reactive Power in a Pure Capacitor

$$Q_C = V \times I \sin\theta$$

$$\sin(-90^\circ) = -1$$

$$\therefore Q_C = V \times I \times -1 = -V \times I \text{ (VAR)}$$

Where $-V \times I \times \sin(\theta)$ is a negative sine wave. Also the symbol for capacitive reactive power is Q_C with the same unit of measure, the volt-ampere reactive (VAR) as that of the inductor. Then we can see that just like a purely inductive circuit above, a pure capacitor does not consume or dissipate any real or true power, P .

AC Power Waveforms for a Pure Capacitor

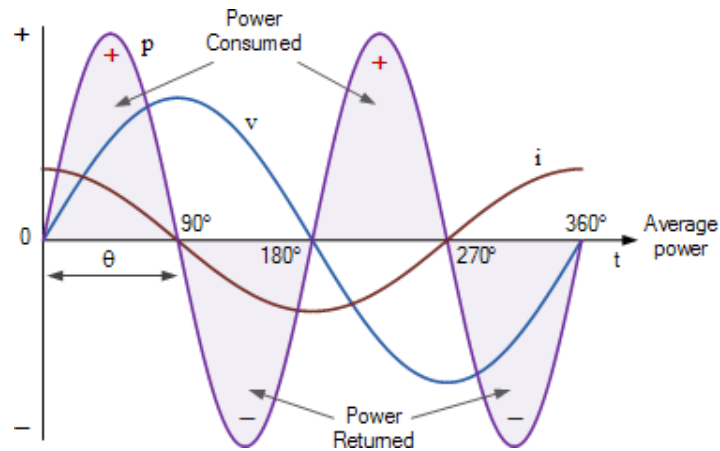

In the positive half of the voltage waveform between the angle of 0° and 90° , both the current and voltage waveforms are positive in value resulting in positive power being consumed. Between 90° and 180° , the capacitor current is negative and the supply voltage is still positive. Therefore, the volt-ampere product gives a negative power as a negative time a positive equal a negative. This negative power indicates that the coil is returning stored electrical energy back to the supply.

In the negative half of the voltage waveform between 180° and 270° , both the capacitors current and the supply voltage are negative in value resulting in a period of positive power. This period of positive power indicates that the coil is consuming electrical energy from the supply. Between 270° and 360° , there is a negative voltage and positive current indicating once again a negative power.

Then during one full-cycle of the voltage waveform the same situation exists as for the purely inductive circuit in that we have two identical positive and negative pulses of power whose average value is zero. Thus the power delivered from the source to the capacitor is exactly equal to the power returned to the source by the capacitor so no real power is used up since the power alternately flows to and from the source. This means then that the total power taken by a pure capacitor over one full-cycle is zero, so the capacitors reactive power does not perform any real work.

Electrical Power Example No2

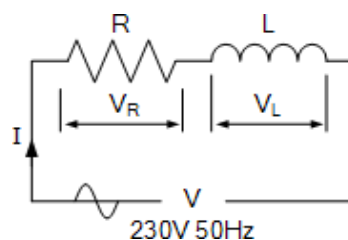

A solenoid coil with a resistance of 30 ohms and an inductance of 200mH is connected to a 230VAC, 50Hz supply. Calculate: (a) the solenoids impedance, (b) the current consumed by the solenoid, (c) the phase angle between the current and the applied voltage, and (d) the average power consumed by the solenoid.

Data given: $R = 30\Omega$, $L = 200\text{mH}$, $V = 230\text{V}$ and $f = 50\text{Hz}$.

(a) Impedance (Z) of the solenoid coil:

$$R = 30\Omega$$

$$X_L = 2\pi fL = 2\pi \times 50 \times 200 \times 10^{-3} = 62.8\Omega$$

$$Z = \sqrt{R^2 + X_L^2} = \sqrt{30^2 + 62.8^2} = 69.6\Omega$$

(b) Current (I) consumed by the solenoid coil:

$$V = I \times Z$$

$$\therefore I = \frac{V}{Z} = \frac{230}{69.6} = 3.3 \text{ A}_{(\text{rms})}$$

(c) The phase angle, θ :

$$\cos\theta = \frac{R}{Z}, \text{ or } \sin\theta = \frac{X_L}{Z}, \text{ or } \tan\theta = \frac{X_L}{R}$$

$$\therefore \cos\theta = \frac{R}{Z} = \frac{30}{69.6} = 0.431$$

$$\cos^{-1}(0.431) = 64.5^\circ \text{ lagging}$$

(d) Average AC power consumed by the solenoid coil:

$$P = V \times I \times \cos\theta$$

$$P = 230 \times 3.3 \times \cos(64.5^\circ)$$

$$\therefore P = 327 \text{ watts}$$

AC Electrical Power Summary

We have seen here that in AC circuits, the voltage and current flowing in a purely passive circuit are normally out-of-phase and, as a result, they can not be used to accomplish any real work. We have also seen that in a direct current (DC) circuit, electrical power is equal to the voltage times the current, or $P = V \cdot I$, but we can not calculate it in the same manner as for AC circuits as we need to take into account any phase difference.

In a purely resistive circuit, the current and voltage are both in-phase and all the electrical power is consumed by the resistance, usually as heat. As a result, none of the electrical power is returned back to the source supply or circuit.

However, in a purely inductive or a purely capacitive circuit that contains reactance, (X) the current will lead or lag the voltage by exactly 90° (the phase angle) so power is both stored and returned back to the source. Thus, the average power calculated over one full periodic cycle will be equal to zero.

The electrical power consumed by a resistance, (R) is called the true or real power and is simply obtained by multiplying the rms voltage with the rms current. The power stored by a reactance, (X) is called the reactive power and is obtained by multiplying the voltage, current, and the sine of the phase angle between them.

The symbol for phase angle is θ (Theta) and which represents the inefficiency of the AC circuit with regards to the total reactive impedance (Z) that opposes the flow of current in the circuit.

13. Power Triangle and Power Factor: -

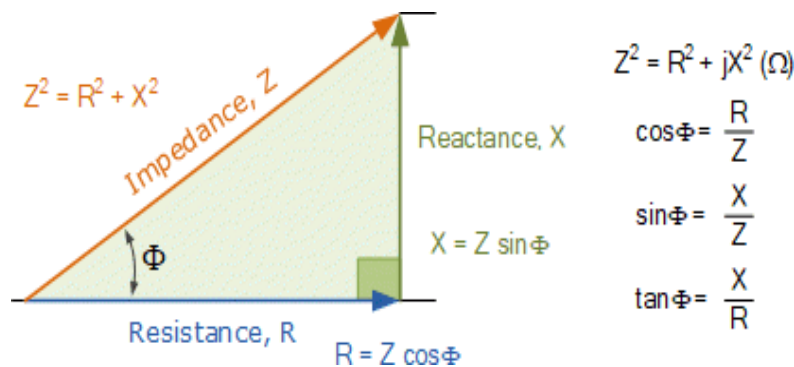

Electrical power consumed in an AC circuit can be represented by the three sides of a right-angled triangle, known commonly as a power triangle

We saw in our tutorial about [Electrical Power](#) that AC circuits which contain resistance and capacitance or resistance and inductance, or both, also contain real power and reactive power. So, in order for us to calculate the total power consumed, we need to know the phase difference between the sinusoidal waveforms of the voltage and current.

In an AC circuit, the voltage and current waveforms are sinusoidal so their amplitudes are constantly changing over time. Since we know that power is voltage times the current ($P = V \cdot I$), maximum power will occur when the two voltage and current waveforms are lined up with each other. That is, their peaks and zero crossover points occur at the same time. When this happens the two waveforms are said to be “in-phase”.

The three main components in an AC circuit which can affect the relationship between the voltage and current waveforms, and therefore their phase difference, by defining the total impedance of the circuit are the resistor, the capacitor and the inductor.

The impedance, (Z) of an AC circuit is equivalent to the resistance calculated in DC circuits, with impedance given in ohms. For AC circuits, impedance is generally defined as the ratio of the voltage and current phasors produced by a circuit component. Phasors are straight lines drawn in such a way as to represent a voltage or current amplitude by its length and its phase difference with respect to other phasor lines by its angular position relative to the other phasor's.

AC circuits contain both resistance and reactance that are combined together to give a total impedance (Z) that limits current flow around the circuit. But an AC circuit's impedance is not equal to the algebraic sum of the resistive and reactive ohmic values as a pure resistance and pure reactance are 90° out-of-phase with each other. But we can use this 90° phase difference as the sides of a right-angled triangle, called an impedance triangle, with the impedance being the hypotenuse as determined by Pythagoras theorem.

This geometric relationship between resistance, reactance and impedance can be represented visually by the use of an impedance triangle as shown.

Impedance Triangle

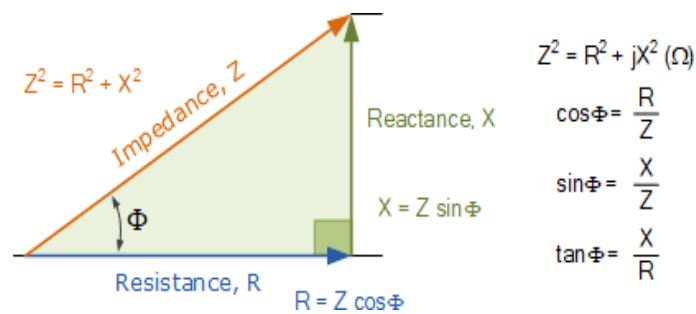

Note that impedance, which is the vector sum of the resistance and reactance, has not only a magnitude (Z) but it also has a phase angle (Φ), which represents the phase difference between the resistance and

the reactance. Also note that the triangle will change shape due to variations in reactance, (X) as the frequency changes. Of course, resistance (R) will always remain constant.

We can take this idea one step further by converting the impedance triangle into a power triangle representing the three elements of power in an AC circuit. Ohms Law tells us that in a DC circuit, power (P), in watts, is equal to the current squared (I^2) times the resistance (R). So we can multiply the three sides of our impedance triangle above by I^2 to obtain the corresponding power triangle as:

$$\text{Real Power } P = I^2R \text{ Watts, (W)}$$

$$\text{Reactive Power } Q = I^2X \text{ Volt-amperes Reactive, (VAr)}$$

$$\text{Apparent Power } S = I^2Z \text{ Volt-amperes, (VA)}$$

Real Power in AC Circuits

Real power (P), also known as true or active power, performs the “real work” within an electrical circuit. Real power, measured in watts, defines the power consumed by the resistive part of a circuit. Then real power, (P) in an AC circuit is the same as power, P in a DC circuit. So just like DC circuits, it is always calculated as $I^2 \cdot R$, where R is the total resistive component of the circuit.

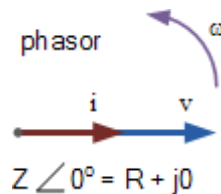

As resistances do not produce any phasor difference (phase shift) between voltage and current waveforms, all the useful power is delivered directly to the resistance and converted to heat, light and work. Then the power consumed by a resistance is real power which is fundamentally the circuits average power.

To find the corresponding value of the real power the rms voltage and current values are multiplied by the cosine of the phase angle, Φ as shown.

$$\text{Real Power } P = I^2R = V \cdot I \cdot \cos(\Phi) \text{ Watts, (W)}$$

But as there is no phase difference between the voltage and the current in a resistive circuit, the phase shift between the two waveforms will be zero (0). Then:

Real Power in an AC Circuit

$$P = V_{\text{rms}} \times I_{\text{rms}} \times \cos\phi$$

$$\cos(0^\circ) = 1$$

$$P = V_{\text{rms}} \times I_{\text{rms}} \times 1$$

$$\therefore P = V_{\text{rms}} \times I_{\text{rms}} \text{ (Watts)}$$

Where real power (P) is in watts, voltage (V) is in rms volts and current (I) is in rms amperes.

Then real power is the $I^2 \cdot R$ resistive element measured in watts, which is what you read on your utility energy meter and has units in Watts (W), Kilowatts (kW), and Megawatts (MW). Note that real power, P is always positive.

Reactive Power in AC Circuits

Reactive power (Q), (sometimes called wattless power) is the power consumed in an AC circuit that does not perform any useful work but has a big effect on the phase shift between the voltage and current waveforms. Reactive power is linked to the reactance produced by inductors and capacitors and counteracts the effects of real power. Reactive power does not exist in DC circuits.

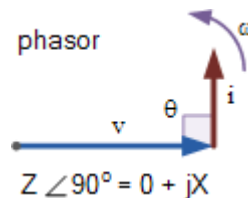

Unlike real power (P) which does all the work, reactive power (Q) takes power away from a circuit due to the creation and reduction of both inductive magnetic fields and capacitive electrostatic fields, thereby making it harder for the true power to supply power directly to a circuit or load.

The power stored by an inductor in its magnetic field tries to control the current, while the power stored by a capacitors electrostatic field tries to control the voltage. The result is that capacitors “generate”

reactive power and inductors “consume” reactive power. This means that they both consume and return power to the source so none of the real power is consumed.

To find reactive power, the rms voltage and current values are multiplied by the sine of the phase angle, Φ as shown.

$$\text{Reactive Power } Q = I^2X = V \cdot I \cdot \sin(\Phi) \text{ volt-amperes reactive, (VAR's)}$$

As there is a 90° phase difference between the voltage and the current waveforms in a pure reactance (either inductive or capacitive), multiplying $V \cdot I$ by $\sin(\Phi)$ gives a vertical component that is 90° out-of-phase with each other, so:

Reactive Power in an AC Circuit

$$Q = V_{\text{rms}} \times I_{\text{rms}} \times \sin\phi$$

$$\sin(90^\circ) = 1$$

$$Q = V_{\text{rms}} \times I_{\text{rms}} \times 1$$

$$\therefore Q = V_{\text{rms}} \times I_{\text{rms}} \text{ (VAr)}$$

Where reactive power (Q) is in volt-amperes reactive, voltage (V) is in rms volts and current (I) is in rms amperes.

Then reactive power represents the product of volts and amperes that are 90° out-of-phase with each other, but in general, there can be any phase angle, Φ between the voltage and the current.

Thus reactive power is the I^2X reactive element that has units in volt-amperes reactive (VAr), kilovolt-amperes reactive (kVAr), and Megavolt-amperes reactive (MVAR).

Apparent Power in AC Circuits

We have seen above that real power is dissipated by resistance and that reactive power is supplied to a reactance. As a result of this the current and voltage waveforms are not in-phase due to the difference between a circuit's resistive and reactive component.

Then there is a mathematical relationship between the real power (P), and the reactive power (Q), called the complex power. The product of the rms voltage, V applied to an AC circuit and the rms current, I flowing into that circuit is called the “volt-ampere product” (VA) given the symbol S and whose magnitude is known generally as apparent power.

This complex Power is not equal to the algebraic sum of the real and reactive powers added together, but is instead the vector sum of P and Q given in volt-amps (VA). It is complex power that is represented by the power triangle. The rms value of the volt-ampere product is known more commonly as the apparent power as, “apparently” this is the total power consumed by a circuit even though the real power that does the work is a lot less.

As apparent power is made up of two parts, the resistive power which is the in-phase power or real power in watts and the reactive power which is the out-of-phase power in volt-amperes, we can show the vector addition of these two power components in the form of a **power triangle**. A power triangle has four parts: P, Q, S and θ .

The three elements which make up power in an AC circuit can be represented graphically by the three sides of a right-angled triangle, in much the same way as the previous impedance triangle. The horizontal (adjacent) side represents the circuits real power (P), the vertical (opposite) side represents the circuits reactive power (Q) and the hypotenuse represents the resulting apparent power (S), of the power triangle as shown.

Power Triangle of an AC Circuit

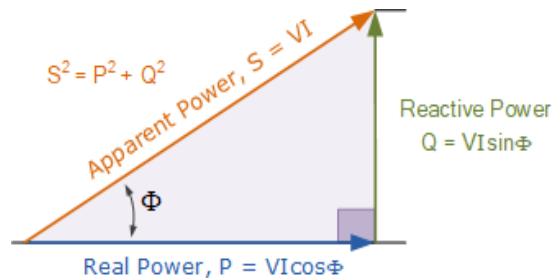

- Where:
- **P** is the $I^2 \cdot R$ or Real power that performs work measured in watts, W
- **Q** is the $I^2 \cdot X$ or Reactive power measured in volt-amperes reactive, VAR
- **S** is the $I^2 \cdot Z$ or Apparent power measured in volt-amperes, VA
- **Φ** is the phase angle in degrees. The larger the phase angle, the greater the reactive power
- $\cos(\Phi) = P/S = W/VA = \text{power factor, p.f.}$
- $\sin(\Phi) = Q/S = \text{VAR}/VA$
- $\tan(\Phi) = Q/P = \text{VAR}/W$

The power factor is calculated as the ratio of the real power to the apparent power because this ratio equals $\cos(\Phi)$.

Power Factor in AC Circuits

Power factor, $\cos(\Phi)$, is an important part of an AC circuit that can also be expressed in terms of circuit impedance or circuit power. Power factor is defined as the ratio of real power (P) to apparent power (S), and is generally expressed as either a decimal value, for example 0.95, or as a percentage: 95%.

Power factor defines the phase angle between the current and voltage waveforms, where I and V are the magnitudes of rms values of the current and voltage. Note that it does not matter whether the phase angle is the difference of the current with respect to the voltage, or the voltage with respect to the current. The mathematical relationship is given as:

Power Factor of an AC Circuit

$$\begin{aligned}\text{Power Factor} &= \frac{\text{watts}}{\text{volt-amperes}} \\ &= \frac{P}{S} = \frac{VI\cos\phi}{VI} = \cos\phi\end{aligned}$$

We said previously that in a pure resistive circuit, the current and voltage waveforms are in-phase with each other so the real power consumed is the same as the apparent power as the phase difference is zero degrees (0°). So, the power factor will be:

$$\text{Power Factor, pf} = \cos 0^\circ = 1.0$$

That is the number of watts consumed is the same as the number of volt-amperes consumed producing a power factor of 1.0, or 100%. In this case it is referred to a unity power factor.

We also said above that in a purely reactive circuit, the current and voltage waveforms are out-of-phase with each other by 90° . As the phase difference is ninety degrees (90°), the power factor will be:

$$\text{Power Factor, pf} = \cos 90^\circ = 0$$

That is the number of watts consumed is zero but there is still a voltage and current supplying the reactive load. Clearly then reducing the reactive VAR component of the power triangle will cause θ to reduce improving the power factor towards one, unity. It is also desirable to have a high-power factor as this makes the most efficient use of the circuit delivering current to a load.

Then we can write the relationship between the real power, the apparent power and the circuits power factor as:

$$\text{Real Power (P)} = \text{Apparant Power (S)} \times \text{Power Factor (pf)}$$

$$\text{Power Factor (pf)} = \frac{\text{Real Power (P) in Watts}}{\text{Apparant Power (S) in volt-amps}}$$

An inductive circuit where the current “lags” the voltage (ELI) is said to have a lagging power factor, and a capacitive circuit where the current “leads” the voltage (ICE) is said to have a leading power factor.

Power Triangle Example No1

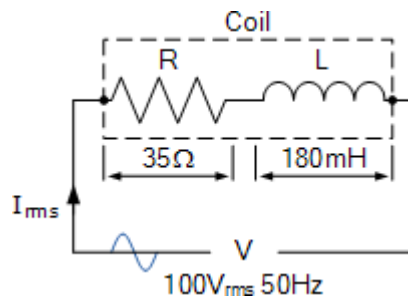

A wound coil that has an inductance of 180mH and a resistance of 35Ω is connected to a 100V 50Hz supply. Calculate: a) the impedance of the coil, b) the current, c) the power factor, and d) the apparent power consumed.

Also draw the resulting power triangle for the above coil.

Data given: R = 35Ω, L = 180mH, V = 100V and f = 50Hz.

(a) Impedance (Z) of the coil:

$$R = 35\Omega$$

$$X_L = 2\pi fL = 2\pi \times 50 \times 0.18 = 56.6\Omega$$

$$Z = \sqrt{R^2 + X_L^2} = \sqrt{35^2 + 56.6^2} = 66.5\Omega$$

(b) Current (I) consumed by the coil:

$$V = I \times Z$$

$$\therefore I = \frac{V}{Z} = \frac{100}{66.5} = 1.5 \text{ A}_{(\text{rms})}$$

(c) The power factor and phase angle, Φ :

$$\cos\phi = \frac{R}{Z}, \text{ or } \sin\phi = \frac{X_L}{Z}, \text{ or } \tan\phi = \frac{X_L}{R}$$

$$\therefore \cos\phi = \frac{R}{Z} = \frac{35}{66.5} = 0.5263$$

$$\cos^{-1}(0.5263) = 58.2^\circ \text{ (lagging)}$$

(d) Apparent power (S) consumed by the coil:

$$P = V \times I \cos\phi = 100 \times 1.5 \times \cos(58.2^\circ) = 79 \text{ W}$$

$$Q = V \times I \sin\phi = 100 \times 1.5 \times \sin(58.2^\circ) = 127.5 \text{ VAr}$$

$$S = V \times I = 100 \times 1.5 = 150 \text{ VA}$$

$$\text{or } S^2 = P^2 + Q^2$$

$$\therefore S = \sqrt{P^2 + Q^2} = \sqrt{79^2 + 127.5^2} = 150 \text{ VA}$$

(e) Power triangle for the coil:

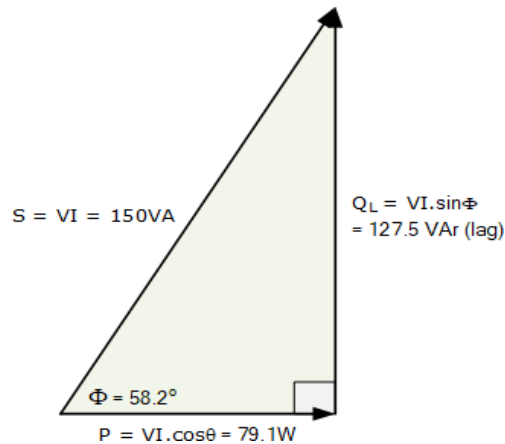

As the power triangle relationships of this simple example demonstrates, at 0.5263 or 52.63% power factor, the coil requires 150 VA of power to produce 79 Watts of useful work. In other words, at 52.63% power factor, the coil takes about 89% more current to do the same work, which is a lot of wasted current.

Adding a power factor correction capacitor (for this example a 32.3uF) across the coil, in order to increase the power factor to over 0.95, or 95%, would greatly reduce the reactive power consumed by the coil as these capacitors act as reactive current generators, thus reducing the total amount of current consumed.

Power Triangle and Power Factor Summary

We have seen here that the three elements of electrical power, *Real Power*, *Reactive Power* and *Apparent Power* in an AC circuit can be represented by the three sides of a triangle called a **Power Triangle**. As these three elements are represented by a “right-angled triangle”, their relationship can be defined as: $S^2 = P^2 + Q^2$, where: P is the real power in watts (W), Q is the reactive power in volt-amperes reactive (VAR) and S is the apparent power in volt-amperes (VA).

We have also seen that in an AC circuit, the quantity $\cos(\Phi)$ is called the power factor. The power factor of an AC circuit is defined as the ratio of the real power (W) consumed by a circuit to the apparent power (VA) consumed by the same circuit. This therefore gives us: Power Factor = Real Power/Apparent Power, or p.f. = W/VA.

Then the cosine of the resulting angle between the current and voltage is the power factor. Generally, power factor is expressed as a percentage, for example 95%, but can also be expressed as a decimal value, for example 0.95.

When the power factor equals 1.0 (unity) or 100%, that is when the real power consumed equals the circuits apparent power, the phase angle between the current and the voltage is 0° as: $\cos^{-1}(1.0) = 0^\circ$. When the power factor equals zero (0), the phase angle between the current and the voltage will be 90° as: $\cos^{-1}(0) = 90^\circ$. In this case the actual power consumed by the AC circuit is zero regardless of the circuit current.

In practical AC circuits, the power factor can be anywhere between 0 and 1.0 depending on the passive components within the connected load. For an inductive-resistive load or circuit (which is most often the case) the power factor will be “lagging”. In a capacitive-resistive circuit the power factor will be “leading”. Then an AC circuit can be defined to have a unity, lagging, or leading power factor.

A poor power factor with a value towards zero (0) will consume wasted power reducing the efficiency of the circuit, while a circuit or load with a power factor closer to one (1.0) or unity (100%), will be more efficient. This is because a circuit or load with a low power factor requires more current than the same circuit or load with a power factor closer to 1.0 (unity).

1. AC Waveform and AC Circuit Theory:-

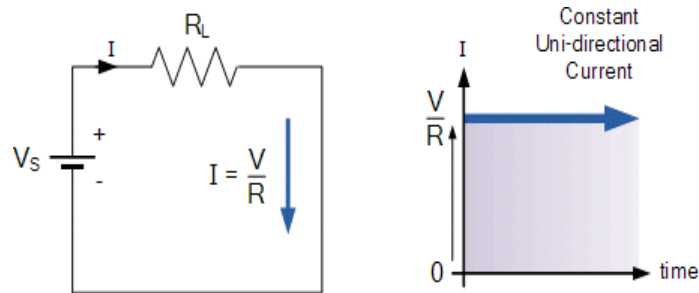

AC Sinusoidal Waveforms are created by rotating a coil within a magnetic field and alternating voltages and currents form the basis of AC Theory.

Direct Current or **D.C.** as it is more commonly called, is a form of electrical current or voltage that flows around an electrical circuit in one direction only, making it a “Uni-directional” supply.

Generally, both DC currents and voltages are produced by power supplies, batteries, dynamos and solar cells to name a few. A DC voltage or current has a fixed magnitude (amplitude) and a definite direction associated with it. For example, +12V represents 12 volts in the positive direction, or -5V represents 5 volts in the negative direction.

We also know that DC power supplies do not change their value with regards to time, they are a constant value flowing in a continuous steady state direction. In other words, DC maintains the same value for all times and a constant uni-directional DC supply never changes or becomes negative unless its connections are physically reversed. An example of a simple DC or direct current circuit is shown below.

DC Circuit and Waveform

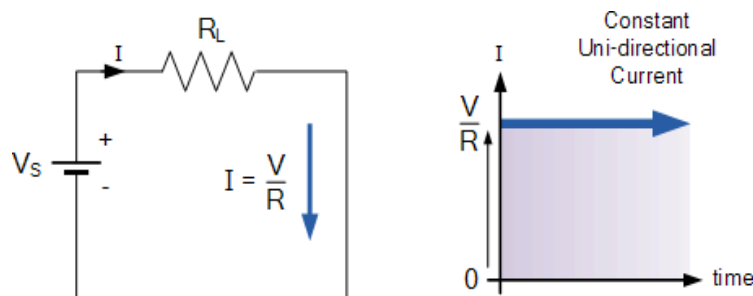

An alternating function or **AC Waveform** on the other hand is defined as one that varies in both magnitude and direction in more or less an even manner with respect to time making it a “Bi-directional” waveform. An AC function can represent either a power source or a signal source with the

shape of an *AC waveform* generally following that of a mathematical sinusoid being defined as: $A(t) = A_{\max} \cdot \sin(2\pi ft)$.

The term AC or to give it its full description of Alternating Current, generally refers to a time-varying waveform with the most common of all being called a **Sinusoid** better known as a **Sinusoidal Waveform**. Sinusoidal waveforms are more generally called by their short description as **Sine Waves**. Sine waves are by far one of the most important types of AC waveform used in electrical engineering.

The shape obtained by plotting the instantaneous ordinate values of either voltage or current against time is called an **AC Waveform**. An AC waveform is constantly changing its polarity every half cycle alternating between a positive maximum value and a negative maximum value respectively with regards to time with a common example of this being the domestic mains voltage supply we use in our homes.

This means then that the *AC Waveform* is a “time-dependent signal” with the most common type of time-dependant signal being that of the **Periodic Waveform**. The periodic or AC waveform is the resulting product of a rotating electrical generator. Generally, the shape of any periodic waveform can be generated using a fundamental frequency and superimposing it with harmonic signals of varying frequencies and amplitudes but that’s for another tutorial.

Alternating voltages and currents can not be stored in batteries or cells like direct current (DC) can, it is much easier and cheaper to generate these quantities using alternators or waveform generators when they are needed. The type and shape of an AC waveform depends upon the generator or device producing them, but all AC waveforms consist of a zero voltage line that divides the waveform into two symmetrical halves. The main characteristics of an **AC Waveform** are defined as:

AC Waveform Characteristics

- **The Period, (T)** is the length of time in seconds that the waveform takes to repeat itself from start to finish. This can also be called the *Periodic Time* of the waveform for sine waves, or the *Pulse Width* for square waves.
- **The Frequency, (f)** is the number of times the waveform repeats itself within a one second time period. Frequency is the reciprocal of the time period, ($f = 1/T$) with the unit of frequency being the **Hertz, (Hz)**.
- **The Amplitude (A)** is the magnitude or intensity of the signal waveform measured in volts or amps.

In our tutorial about [Waveforms](#), we looked at different types of waveforms and said that “**Waveforms** are basically a visual representation of the variation of a voltage or current plotted to a base of time”. Generally, for AC waveforms this horizontal base line represents a zero condition of either voltage or current. Any part of an AC type waveform which lies above the horizontal zero axis represents a voltage or current flowing in one direction.

Likewise, any part of the waveform which lies below the horizontal zero axis represents a voltage or current flowing in the opposite direction to the first. Generally for sinusoidal AC waveforms the shape of the waveform above the zero axis is the same as the shape below it. However, for most non-power AC signals including audio waveforms this is not always the case.

The most common periodic signal waveforms that are used in Electrical and Electronic Engineering are the *Sinusoidal Waveforms*. However, an alternating AC waveform may not always take the shape of a smooth shape based around the trigonometric sine or cosine function. AC waveforms can also take the shape of either *Complex Waves*, *Square Waves* or *Triangular Waves* and these are shown below.

Types of Periodic Waveform

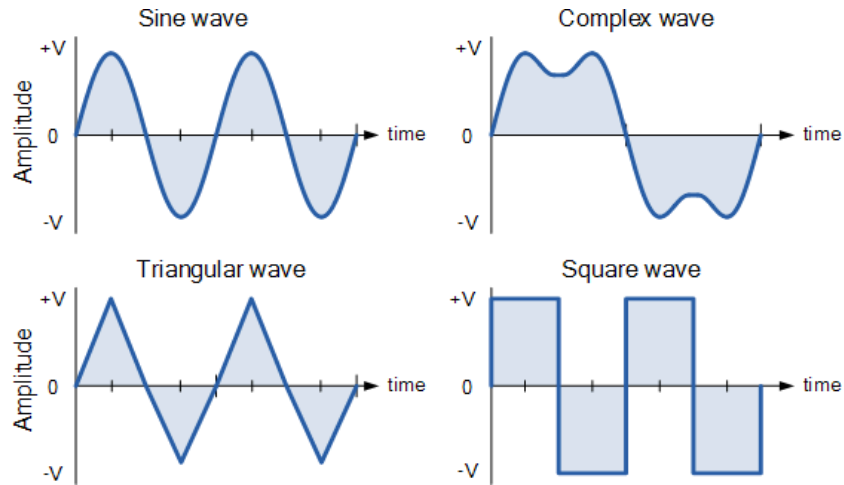

The time taken for an **AC Waveform** to complete one full pattern from its positive half to its negative half and back to its zero baseline again is called a **Cycle** and one complete cycle contains both a positive half-cycle and a negative half-cycle. The time taken by the waveform to complete one full cycle is called the **Periodic Time** of the waveform, and is given the symbol “T”.

The number of complete cycles that are produced within one second (cycles/second) is called the **Frequency**, symbol f of the alternating waveform. Frequency is measured in **Hertz**, (Hz) named after the German physicist Heinrich Hertz.

Then we can see that a relationship exists between cycles (oscillations), periodic time and frequency (cycles per second), so if there are f number of cycles in one second, each individual cycle must take $1/f$ seconds to complete.

Relationship Between Frequency and Periodic Time

$$\text{Frequency, } (f) = \frac{1}{\text{Periodic Time}} = \frac{1}{T} \text{ Hertz}$$

or

$$\text{Periodic Time, } (T) = \frac{1}{\text{Frequency}} = \frac{1}{f} \text{ seconds}$$

AC Waveform Example No1

1. What will be the periodic time of a 50Hz waveform and
2. what is the frequency of an AC waveform that has a periodic time of 10ms.

1).

$$\text{Periodic Time, (T)} = \frac{1}{f} = \frac{1}{50} = 0.02\text{secs or } 20\text{ms}$$

2).

$$\text{Frequency, (f)} = \frac{1}{T} = \frac{1}{10 \times 10^{-3}} = 100\text{Hz}$$

Frequency used to be expressed in “cycles per second” abbreviated to “cps”, but today it is more commonly specified in units called “Hertz”. For a domestic mains supply the frequency will be either 50Hz or 60Hz depending upon the country and is fixed by the speed of rotation of the generator. But one hertz is a very small unit so prefixes are used that denote the order of magnitude of the waveform at higher frequencies such as **kHz**, **MHz** and even **GHz**.

Definition of Frequency Prefixes

Kilo	Thousand	kHz	1ms
Mega	Million	MHz	1us
Giga	Billion	GHz	1ns
Terra	Trillion	THz	1ps

Amplitude of an AC Waveform

As well as knowing either the periodic time or the frequency of the alternating quantity, another important parameter of the AC waveform is **Amplitude**, better known as its Maximum or Peak value represented by the terms, V_{max} for voltage or I_{max} for current.

The peak value is the greatest value of either voltage or current that the waveform reaches during each half cycle measured from the zero baseline. Unlike a DC voltage or current which has a steady state that can be measured or calculated using [Ohm's Law](#), an alternating quantity is constantly changing its value over time.

For pure sinusoidal waveforms this peak value will always be the same for both half cycles ($+V_m = -V_m$) but for non-sinusoidal or complex waveforms the maximum peak value can be very different for each half cycle. Sometimes, alternating waveforms are given a *peak-to-peak*, V_{p-p} value and this is simply the

distance or the sum in voltage between the maximum peak value, $+V_{max}$ and the minimum peak value, $-V_{max}$ during one complete cycle.

The Average Value of an AC Waveform

The average or mean value of a continuous DC voltage will always be equal to its maximum peak value as a DC voltage is constant. This average value will only change if the duty cycle of the DC voltage changes. In a pure sine wave if the average value is calculated over the full cycle, the average value would be equal to zero as the positive and negative halves will cancel each other out. So the average or mean value of an AC waveform is calculated or measured over a half cycle only and this is shown below.

Average Value of a Non-sinusoidal Waveform

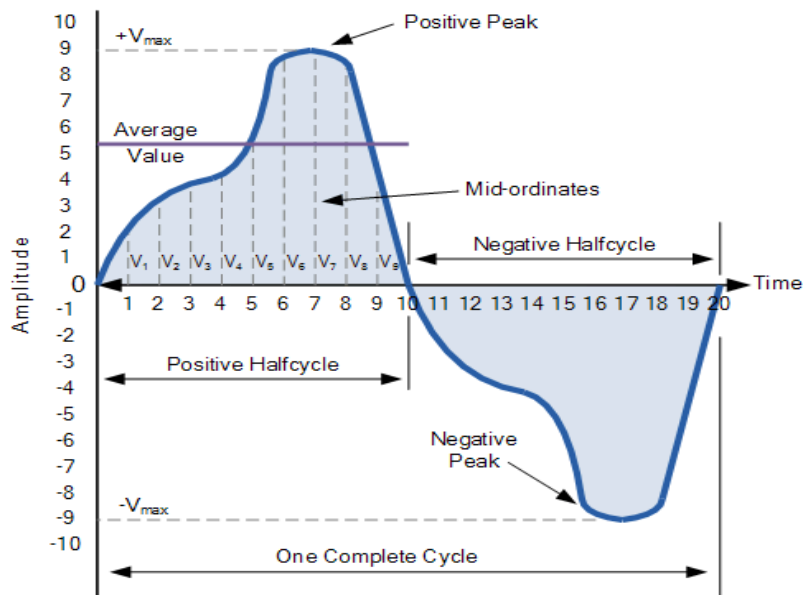

To find the average value of the waveform we need to calculate the area underneath the waveform using the mid-ordinate rule, trapezoidal rule or the Simpson's rule found commonly in mathematics. The approximate area under any irregular waveform can easily be found by simply using the mid-ordinate rule.

The zero axis base line is divided up into any number of equal parts and in our simple example above this value was nine, (V_1 to V_9). The more ordinate lines that are drawn the more accurate will be the final average or mean value. The average value will be the addition of all the instantaneous values added together and then divided by the total number. This is given as.

Average Value of an AC Waveform

$$V_{\text{average}} = \frac{V_1 + V_2 + V_3 + V_4 + \dots + V_n}{n}$$

Where: n equals the actual number of mid-ordinates used.

For a pure sinusoidal waveform this average or mean value will always be equal to $0.637 \cdot V_{\text{max}}$ and this relationship also holds true for average values of current.

The RMS Value of an AC Waveform

The average value of an AC waveform that we calculated above as being: $0.637 \cdot V_{\text{max}}$ is NOT the same value we would use for a DC supply. This is because unlike a DC supply which is constant and of a fixed value, an AC waveform is constantly changing over time and has no fixed value. Thus the equivalent value for an alternating current system that provides the same amount of electrical power to a load as a DC equivalent circuit is called the “effective value”.

The effective value of a sine wave produces the same $I^2 \cdot R$ heating effect in a load as we would expect to see if the same load was fed by a constant DC supply. The effective value of a sine wave is more commonly known as the **Root Mean Squared** or simply **RMS** value as it is calculated as the square root of the mean (average) of the square of the voltage or current.

That is V_{rms} or I_{rms} is given as the square root of the average of the sum of all the squared mid-ordinate values of the sine wave. The RMS value for any AC waveform can be found from the following modified average value formula as shown.

RMS Value of an AC Waveform

$$V_{\text{RMS}} = \sqrt{\frac{V_1^2 + V_2^2 + V_3^2 + V_4^2 + \dots + V_n^2}{n}}$$

Where: n equals the number of mid-ordinates.

For a pure sinusoidal waveform this **effective or R.M.S. value** will always be equal to: $1/\sqrt{2} \cdot V_{\text{max}}$ which is **equal to $0.707 \cdot V_{\text{max}}$** and this relationship holds true for RMS values of current. The RMS value for a sinusoidal waveform is always greater than the average value except for a rectangular waveform. In this case the heating effect remains constant so the average and the RMS values will be the same.

One final comment about R.M.S. values. Most multimeters, either digital or analogue unless otherwise stated only measure the R.M.S. values of voltage and current and not the average. Therefore when using a multimeter on a direct current system the reading will be equal to $I = V/R$ and for an alternating current system the reading will be equal to $I_{\text{rms}} = V_{\text{rms}}/R$.

Also, except for average power calculations, when calculating RMS or peak voltages, only use V_{RMS} to find I_{RMS} values, or peak voltage, V_p to find peak current, I_p values. Do not mix them together as Average, RMS or Peak values of a sine wave are completely different and your results will definitely be incorrect.

Form Factor and Crest Factor

Although little used these days, both **Form Factor** and **Crest Factor** can be used to give information about the actual shape of the AC waveform. Form Factor is the ratio between the average value and the RMS value and is given as.

$$\text{Form Factor} = \frac{\text{R.M.S value}}{\text{Average value}} = \frac{0.707 \times V_{\max}}{0.637 \times V_{\max}}$$

For a pure sinusoidal waveform the Form Factor will always be equal to 1.11. Crest Factor is the ratio between the R.M.S. value and the Peak value of the waveform and is given as.

$$\text{Crest Factor} = \frac{\text{Peak value}}{\text{R.M.S. value}} = \frac{V_{\max}}{0.707 \times V_{\max}}$$

For a pure sinusoidal waveform the Crest Factor will always be equal to 1.414.

AC Waveform Example No2

A sinusoidal alternating current of 6 amps is flowing through a resistance of 40Ω. Calculate the average voltage and the peak voltage of the supply.

The R.M.S. Voltage value is calculated as:

$$V_{\text{RMS}} = I \times R = 6 \times 40 = 240\text{V}$$

The Average Voltage value is calculated as:

$$\text{Form Factor} = \frac{V_{\text{RMS}}}{V_{\text{average}}}$$
$$\therefore V_{\text{average}} = \frac{V_{\text{RMS}}}{\text{Form Factor}} = \frac{240}{1.11} = 216.2 \text{ volts}$$

The Peak Voltage value is calculated as:

$$\text{Peak Voltage} = \text{R.M.S.} \times 1.414$$

$$\therefore 240 \times 1.414 = 339.4 \text{ volts}$$

The use and calculation of Average, R.M.S, Form factor and Crest Factor can also be use with any type of periodic waveform including Triangular, Square, Sawtoothed or any other irregular or complex voltage/current waveform shape. Conversion between the various sinusoidal values can sometimes be confusing so the following table gives a convenient way of converting one sine wave value to another.

2. Sinusoidal Waveforms:-

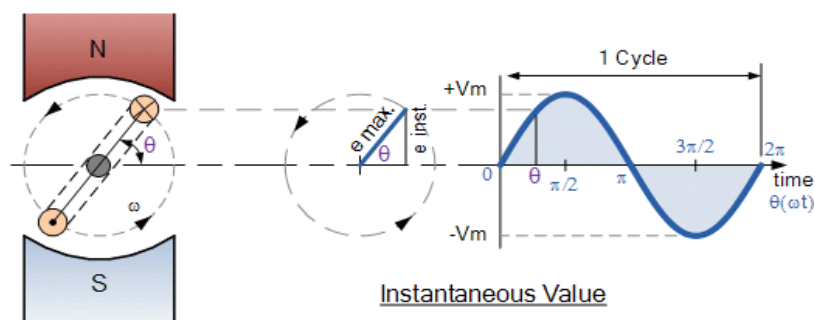

When an electric current flows through a wire or conductor, a circular magnetic field is created around the wire and whose strength is related to the current value.

If this single wire conductor is moved or rotated within a stationary magnetic field, an “EMF”, (Electro-Motive Force) is induced within the conductor due to the movement of the conductor through the magnetic flux.

From this we can see that a relationship exists between Electricity and Magnetism giving us, as Michael Faraday discovered the effect of “Electromagnetic Induction” and it is this basic principal that electrical machines and generators use to generate a **Sinusoidal Waveform** for our mains supply.

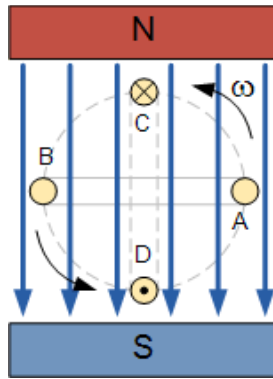

In the [Electromagnetic Induction](#), tutorial we said that when a single wire conductor moves through a permanent magnetic field thereby cutting its lines of flux, an EMF is induced in it.

However, if the conductor moves in parallel with the magnetic field in the case of points A and B, no lines of flux are cut and no EMF is induced into the conductor, but if the conductor moves at right angles to the magnetic field as in the case of points C and D, the maximum amount of magnetic flux is cut producing the maximum amount of induced EMF.

Also, as the conductor cuts the magnetic field at different angles between points A and C, 0 and 90° the amount of induced EMF will lie somewhere between this zero and maximum value. Then the amount of emf induced within a conductor depends on the angle between the conductor and the magnetic flux as well as the strength of the magnetic field.

An AC generator uses the principal of Faraday's electromagnetic induction to convert a mechanical energy such as rotation, into electrical energy, a **Sinusoidal Waveform**. A simple generator consists of a pair of permanent magnets producing a fixed magnetic field between a north and a south pole. Inside this magnetic field is a single rectangular loop of wire that can be rotated around a fixed axis allowing it to cut the magnetic flux at various angles as shown below.

Basic Single Coil AC Generator

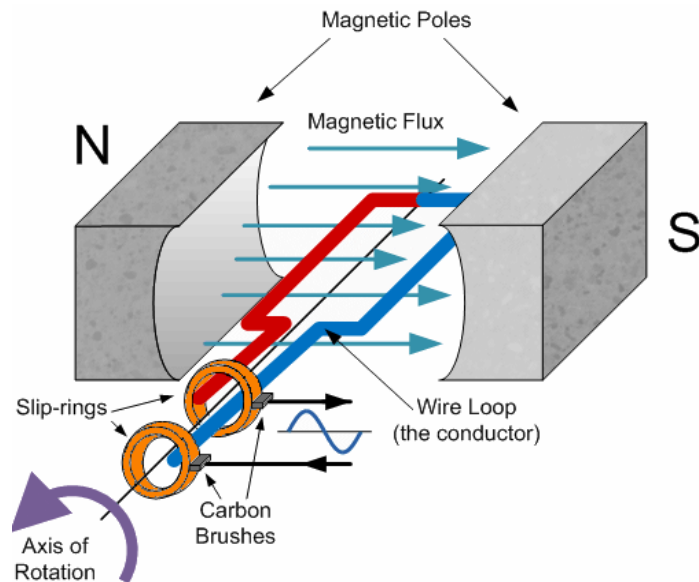

As the coil rotates anticlockwise around the central axis which is perpendicular to the magnetic field, the wire loop cuts the lines of magnetic force set up between the north and south poles at different angles as the loop rotates. The amount of induced EMF in the loop at any instant of time is proportional to the angle of rotation of the wire loop.

As this wire loop rotates, electrons in the wire flow in one direction around the loop. Now when the wire loop has rotated past the 180° point and moves across the magnetic lines of force in the opposite direction, the electrons in the wire loop change and flow in the opposite direction. Then the direction of the electron movement determines the polarity of the induced voltage.

So we can see that when the loop or coil physically rotates one complete revolution, or 360°, one full sinusoidal waveform is produced with one cycle of the waveform being produced for each revolution of the coil. As the coil rotates within the magnetic field, the electrical connections are made to the coil by means of carbon brushes and slip-rings which are used to transfer the electrical current induced in the coil.

The amount of EMF induced into a coil cutting the magnetic lines of force is determined by the following three factors.

- **Speed** – the speed at which the coil rotates inside the magnetic field.
- **Strength** – the strength of the magnetic field.
- **Length** – the length of the coil or conductor passing through the magnetic field.

We know that the frequency of a supply is the number of times a cycle appears in one second and that frequency is measured in Hertz. As one cycle of induced emf is produced each full revolution of the coil through a magnetic field comprising of a north and south pole as shown above, if the coil rotates at a constant speed a constant number of cycles will be produced per second giving a constant frequency. So by increasing the speed of rotation of the coil the frequency will also be increased. Therefore, frequency is proportional to the speed of rotation, ($f \propto N$) where $N = \text{r.p.m.}$

Also, our simple single coil generator above only has two poles, one north and one south pole, giving just one pair of poles. If we add more magnetic poles to the generator above so that it now has four poles in total, two north and two south, then for each revolution of the coil two cycles will be produced for the same rotational speed. Therefore, frequency is proportional to the number of pairs of magnetic poles, ($f \propto P$) of the generator where P = the number of "pairs of poles".

Then from these two facts we can say that the frequency output from an AC generator is:

$$f \propto N, \quad \text{and} \quad f \propto P$$

$$\therefore f = \frac{N \times P}{60} \quad \text{in cycles/min}$$

As frequency is measured in Hertz

$$\text{Frequency, } (f) = \frac{NP}{60} \text{ Hz}$$

Where: N is the speed of rotation in r.p.m. P is the number of "pairs of poles" and 60 converts it into seconds.

Instantaneous Voltage

The EMF induced in the coil at any instant of time depends upon the rate or speed at which the coil cuts the lines of magnetic flux between the poles and this is dependent upon the angle of rotation, Theta (θ) of the generating device. Because an AC waveform is constantly changing its value or amplitude, the waveform at any instant in time will have a different value from its next instant in time.

For example, the value at 1ms will be different to the value at 1.2ms and so on. These values are known generally as the **Instantaneous Values**, or V_i . Then the instantaneous value of the waveform and also its direction will vary according to the position of the coil within the magnetic field as shown below.

Displacement of a Coil within a Magnetic Field

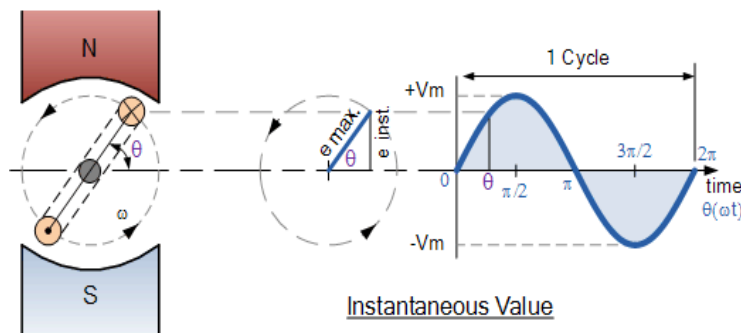

The instantaneous values of a sinusoidal waveform is given as the “Instantaneous value = Maximum value x sin θ ” and this is generalized by the formula.

$$V_i = V_{\max} \times \sin\theta$$

Where, V_{\max} is the maximum voltage induced in the coil and $\theta = \omega t$, is the rotational angle of the coil with respect to time.

If we know the maximum or peak value of the waveform, by using the formula above the instantaneous values at various points along the waveform can be calculated. By plotting these values out onto graph paper, a sinusoidal waveform shape can be constructed.

In order to keep things simple we will plot the instantaneous values for the sinusoidal waveform at every 45° of rotation giving us 8 points to plot. Again, to keep it simple we will assume a maximum voltage, V_{\max} value of 100V. Plotting the instantaneous values at shorter intervals, for example at every 30° (12 points) or 10° (36 points) for example would result in a more accurate sinusoidal waveform construction.

Sinusoidal Waveform Construction

$e = V_{\max} \cdot \sin\theta$	0	70.71	100	70.71	0	-70.71	-100	-70.71	0
---------------------------------	---	-------	-----	-------	---	--------	------	--------	---

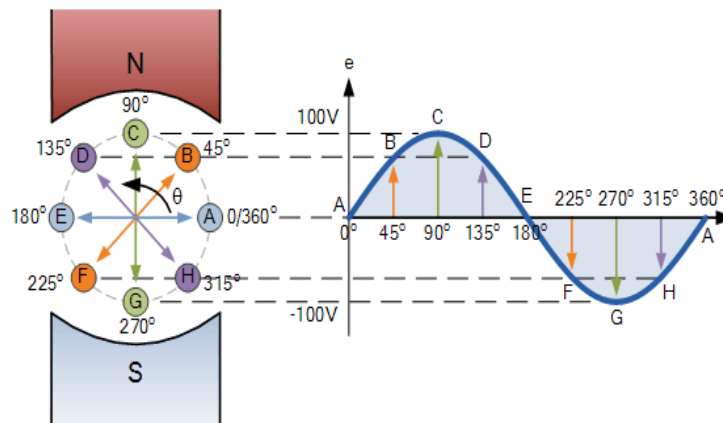

The points on the sinusoidal waveform are obtained by projecting across from the various positions of rotation between 0° and 360° to the ordinate of the waveform that corresponds to the angle, θ and when the wire loop or coil rotates one complete revolution, or 360° , one full waveform is produced.

From the plot of the sinusoidal waveform we can see that when θ is equal to 0° , 180° or 360° , the generated EMF is zero as the coil cuts the minimum amount of lines of flux. But when θ is equal to 90° and 270° the generated EMF is at its maximum value as the maximum amount of flux is cut.

Therefore a sinusoidal waveform has a positive peak at 90° and a negative peak at 270° . Positions B, D, F and H generate a value of EMF corresponding to the formula: $e = V_{\max} \sin \theta$.

Then the waveform shape produced by our simple single loop generator is commonly referred to as a **Sine Wave** as it is said to be sinusoidal in its shape. This type of waveform is called a sine wave because it is based on the trigonometric sine function used in mathematics, ($x(t) = A_{\max} \sin \theta$).

When dealing with sine waves in the time domain and especially current related sine waves the unit of measurement used along the horizontal axis of the waveform can be either time, degrees or radians. In electrical engineering it is more common to use the **Radian** as the angular measurement of the angle along the horizontal axis rather than degrees. For example, $\omega = 100 \text{ rad/s}$, or 500 rad/s .

Radians

The **Radian**, (rad) is defined mathematically as a quadrant of a circle where the distance subtended on the circumference of the circle is equal to the length of the radius (r) of the same circle. Since the circumference of a circle is equal to $2\pi \times \text{radius}$, there must be 2π radians around the 360° of a circle.

In other words, the radian is a unit of angular measurement and the length of one radian (r) will fit 6.284 ($2 \times \pi$) times around the whole circumference of a circle. Thus one radian equals $360^\circ / 2\pi = 57.3^\circ$. In electrical engineering the use of radians is very common so it is important to remember the following formula.

Definition of a Radian

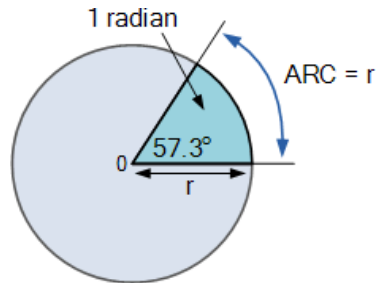

$$2\pi \text{ rads} = 360^\circ$$

$$\therefore 1 \text{ rad} = 57.3^\circ$$

Using radians as the unit of measurement for a sinusoidal waveform would give 2π radians for one full cycle of 360° . Then half a sinusoidal waveform must be equal to 1π radians or just π (pi). Then knowing that pi, (π) is equal to 3.142, the relationship between degrees and radians for a sinusoidal waveform is therefore given as:

Relationship between Degrees and Radians

$$\text{Radians} = \left(\frac{\pi}{180^\circ} \right) \times \text{degrees}$$

$$\text{Degrees} = \left(\frac{180^\circ}{\pi} \right) \times \text{radians}$$

Applying these two equations to various points along the waveform gives us.

$$30^\circ \rightarrow \text{Radians} = \frac{\pi}{180^\circ}(30^\circ) = \frac{\pi}{6} \text{ rad.}$$

$$90^\circ \rightarrow \text{Radians} = \frac{\pi}{180^\circ}(90^\circ) = \frac{\pi}{2} \text{ rad.}$$

$$\frac{5\pi}{4} \text{ rad} \rightarrow \text{Degrees} = \frac{180^\circ}{\pi} \left(\frac{5\pi}{4} \right) = 225^\circ$$

$$\frac{3\pi}{2} \text{ rad} \rightarrow \text{Degrees} = \frac{180^\circ}{\pi} \left(\frac{3\pi}{2} \right) = 270^\circ$$

The conversion between degrees and radians for the more common equivalents used in sinusoidal analysis are given in the following table.

Relationship between Degrees and Radians

0°	0	135°	$\frac{3\pi}{4}$	270°	$\frac{3\pi}{2}$
30°	$\frac{\pi}{6}$	150°	$\frac{5\pi}{6}$	300°	$\frac{5\pi}{3}$
45°	$\frac{\pi}{4}$	180°	π	315°	$\frac{7\pi}{4}$
60°	$\frac{\pi}{3}$	210°	$\frac{7\pi}{6}$	330°	$\frac{11\pi}{6}$
90°	$\frac{\pi}{2}$	225°	$\frac{5\pi}{4}$	360°	2π
120°	$\frac{2\pi}{3}$	240°	$\frac{4\pi}{3}$		

The velocity at which the generator rotates around its central axis determines the frequency of the sinusoidal waveform. As the frequency of the waveform is given as f Hz or cycles per second, the waveform also has angular frequency, ω , (Greek letter omega), in radians per second. Then the angular velocity of a sinusoidal waveform is given as.

Angular Velocity of a Sinusoidal Waveform

$$\omega = 2\pi f \text{ (rad/sec)}$$

and in the United Kingdom, the angular velocity or frequency of the mains supply is given as:

$$\omega = 2\pi f = 2\pi \cdot 50 = 314.2 \text{ rad/s}$$

in the USA as their mains supply frequency is 60Hz it can be given as: 377 rad/s

So we now know that the velocity at which the generator rotates around its central axis determines the frequency of the sinusoidal waveform and which can also be called its **angular velocity**, ω . But we should by now also know that the time required to complete one full revolution is equal to the periodic time, (T) of the sinusoidal waveform.

As frequency is inversely proportional to its time period, $f = 1/T$ we can therefore substitute the frequency quantity in the above equation for the equivalent periodic time quantity and substituting gives us.

$$\omega = \frac{2\pi}{T} \text{ (rad/sec)}$$

The above equation states that for a smaller periodic time of the sinusoidal waveform, the greater must be the angular velocity of the waveform. Likewise in the equation above for the frequency quantity, the higher the frequency the higher the angular velocity.

Sinusoidal Waveform Example No1

A sinusoidal waveform is defined as: $V_m = 169.8 \sin(377t)$ volts. Calculate the RMS voltage of the waveform, its frequency and the instantaneous value of the voltage, (V_i) after a time of six milliseconds (6ms).

We know from above that the general expression given for a sinusoidal waveform is:

$$V_{(t)} = V_m \sin(\omega t)$$

Then comparing this to our given expression for a sinusoidal waveform above of $V_m = 169.8 \sin(377t)$ will give us the peak voltage value of 169.8 volts for the waveform.

The waveforms RMS voltage is calculated as:

$$V_{(rms)} = 0.707 \times \text{maximum peak value}$$

$$V_{(rms)} = 0.707 \times 169.8 = 120 \text{ volts}$$

The angular velocity (ω) is given as 377 rad/s. Then $2\pi f = 377$. So the frequency of the waveform is calculated as:

$$\text{Frequency, } (f) = \frac{377}{2\pi} = 60 \text{ Hz}$$

The instantaneous voltage V_i value after a time of 6mS is given as:

$$V_{(i)} = V_m \sin(\omega t)$$

$$V_{(i)} = 169.8 \sin(377 \times 0.006)$$

$$V_{(i)} = 169.8 \sin(2.262 \text{ rads})$$

$$2.262 \text{ rads} \times 57.3^\circ = 129.6^\circ$$

$$V_{(i)} = 169.8 \sin(129.6^\circ) = 169.8 \times 0.771$$

$$\therefore V_{(i)} = 130.8 \text{ volts peak}$$

Note that the angular velocity at time $t = 6\text{mS}$ is given in radians (rads). We could, if so wished, convert this into an equivalent angle in degrees and use this value instead to calculate the instantaneous voltage value. The angle in degrees of the instantaneous voltage value is therefore given as:

$$\text{Degrees} = \left(\frac{180^\circ}{\pi} \right) \times \text{radians}$$

$$\therefore \frac{180^\circ}{\pi} \times 2.262 = 57.3^\circ \times 2.262 = 129.6^\circ$$

Sinusoidal Waveform

Then the generalised format used for analysing and calculating the various values of a **Sinusoidal Waveform** is as follows:

A Sinusoidal Waveform

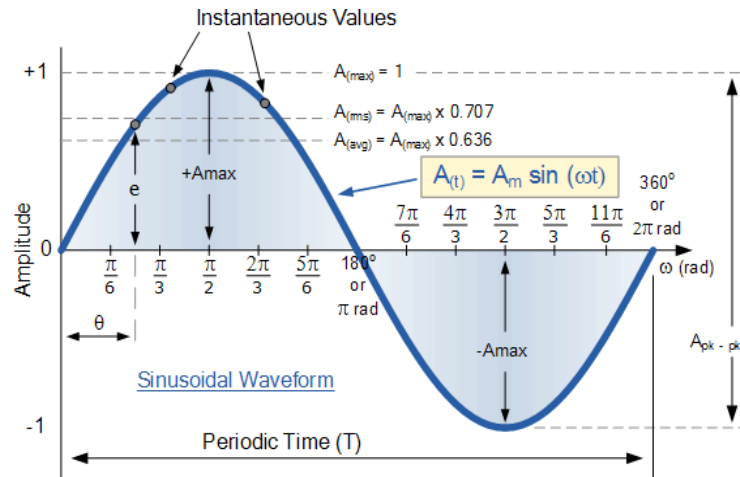

3. Phase Difference and Phase Shift

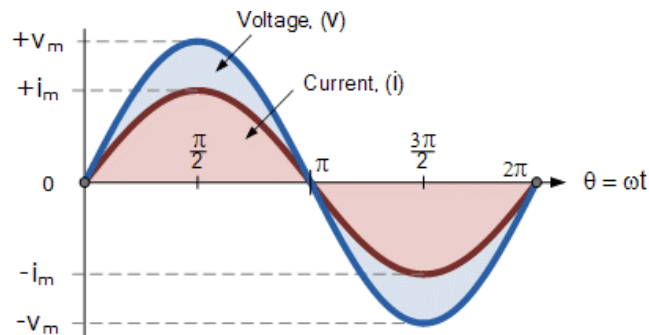

Phase Difference is used to describe the difference in degrees or radians when two or more alternating quantities reach their maximum or zero values

Previously we saw that a Sinusoidal Waveform is an alternating quantity that can be presented graphically in the time domain along an horizontal zero axis. We also saw that as an alternating quantity, sine waves have a positive maximum value at time $\pi/2$, a negative maximum value at time $3\pi/2$, with zero values occurring along the baseline at $0, \pi$ and 2π .

However, not all sinusoidal waveforms will pass exactly through the zero axis point at the same time, but may be “shifted” to the right or to the left of 0° by some value when compared to another sine wave.

For example, comparing a voltage waveform to that of a current waveform. This then produces an angular shift or **Phase Difference** between the two sinusoidal waveforms. Any sine wave that does not pass through zero at $t = 0$ has a phase shift.

The **phase difference** or phase shift as it is also called of a Sinusoidal Waveform is the angle Φ (Greek letter Phi), in degrees or radians that the waveform has shifted from a certain reference point along the horizontal zero axis. In other words phase shift is the lateral difference between two or more waveforms along a common axis and sinusoidal waveforms of the same frequency can have a phase difference.

The phase difference, Φ of an alternating waveform can vary from between 0 to its maximum time period, T of the waveform during one complete cycle and this can be anywhere along the horizontal axis between, $\Phi = 0$ to 2π (radians) or $\Phi = 0$ to 360° depending upon the angular units used.

Phase difference can also be expressed as a *time shift* of τ in seconds representing a fraction of the time period, T for example, $+10\text{mS}$ or $-50\mu\text{S}$ but generally it is more common to express phase difference as an angular measurement.

Then the equation for the instantaneous value of a sinusoidal voltage or current waveform we developed in the previous Sinusoidal Waveform will need to be modified to take account of the phase angle of the waveform and this new general expression becomes.

Phase Difference Equation

$$A_{(t)} = A_{\text{max}} \times \sin(\omega t \pm \Phi)$$

- Where:
- A_m – is the amplitude of the waveform.
- ωt – is the angular frequency of the waveform in radian/sec.
- Φ (phi) – is the phase angle in degrees or radians that the waveform has shifted either left or right from the reference point.

If the positive slope of the sinusoidal waveform passes through the horizontal axis “before” $t = 0$ then the waveform has shifted to the left so $\Phi > 0$, and the phase angle will be positive in nature, $+\Phi$ giving a leading phase angle. In other words it appears earlier in time than 0° producing an anticlockwise rotation of the vector.

Likewise, if the positive slope of the sinusoidal waveform passes through the horizontal x-axis some time “after” $t = 0$ then the waveform has shifted to the right so $\Phi < 0$, and the phase angle will be negative in nature $-\Phi$ producing a lagging phase angle as it appears later in time than 0° producing a clockwise rotation of the vector. Both cases are shown below.

Phase Relationship of a Sinusoidal Waveform

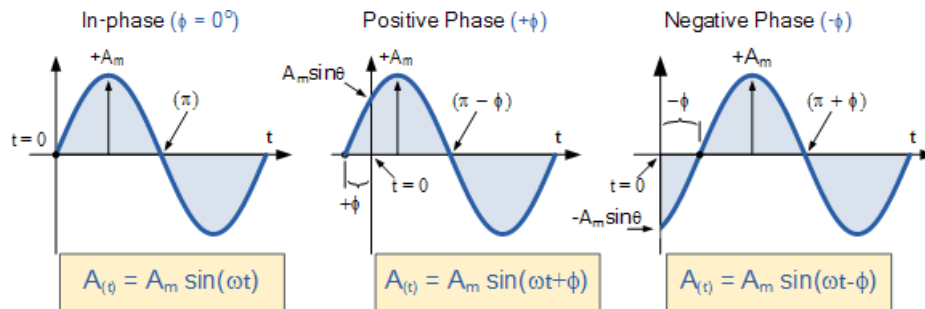

Firstly, let's consider that two alternating quantities such as a voltage, v and a current, i have the same frequency f in Hertz. As the frequency of the two quantities is the same the angular velocity, ω must also be the same. So at any instant in time we can say that the phase of voltage, v will be the same as the phase of the current, i .

Then the angle of rotation within a particular time period will always be the same and the phase difference between the two quantities of v and i will therefore be zero and $\Phi = 0$. As the frequency of the voltage, v and the current, i are the same they must both reach their maximum positive, negative and zero values during one complete cycle at the same time (although their amplitudes may be different). Then the two alternating quantities, v and i are said to be "in-phase".

Two Sinusoidal Waveforms – "in-phase"

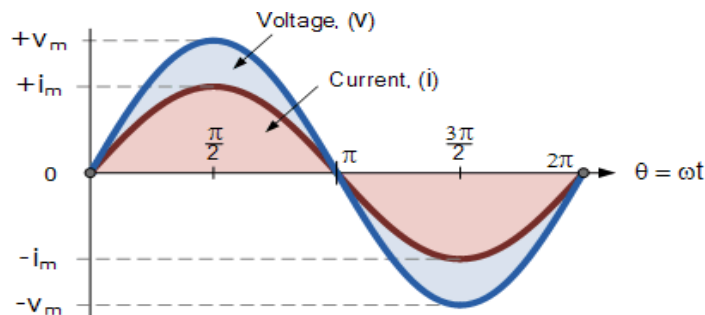

Now let's consider that the voltage, v and the current, i have a phase difference between themselves of 30° , so ($\Phi = 30^\circ$ or $\pi/6$ radians). As both alternating quantities rotate at the same speed, i.e. they have the same frequency, this phase difference will remain constant for all instants in time, then the phase difference of 30° between the two quantities is represented by ϕ , Φ as shown below.

Phase Difference of a Sinusoidal Waveform

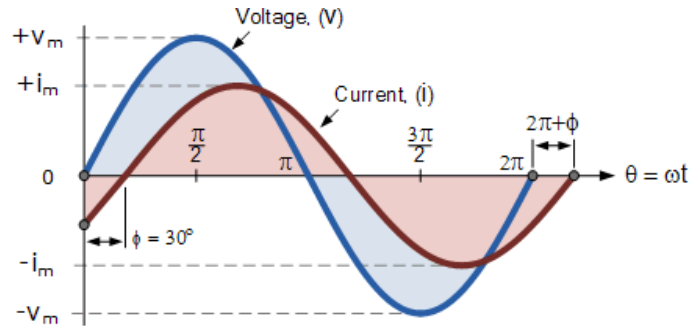

The voltage waveform above starts at zero along the horizontal reference axis, but at that same instant of time the current waveform is still negative in value and does not cross this reference axis until 30° later. Then there exists a **Phase difference** between the two waveforms as the current crosses the horizontal reference axis reaching its maximum peak and zero values after the voltage waveform.

As the two waveforms are no longer “in-phase”, they must therefore be “out-of-phase” by an amount determined by phi, Φ and in our example this is 30° . So we can say that the two waveforms are now 30° out-of-phase. The current waveform can also be said to be “lagging” behind the voltage waveform by the phase angle, Φ . Then in our example above the two waveforms have a **Lagging Phase Difference** so the expression for both the voltage and current above will be given as.

$$\text{Voltage, } (v_t) = V_m \sin \omega t$$

$$\text{Current, } (i_t) = I_m \sin(\omega t - \theta)$$

where, i lags v by angle Φ

Likewise, if the current, i has a positive value and crosses the reference axis reaching its maximum peak and zero values at some time before the voltage, v then the current waveform will be “leading” the voltage by some phase angle. Then the two waveforms are said to have a **Leading Phase Difference** and the expression for both the voltage and the current will be.

$$\text{Voltage, } (v_t) = V_m \sin \omega t$$

$$\text{Current, } (i_t) = I_m \sin(\omega t + \theta)$$

where, i leads v by angle Φ

The phase angle of a sine wave can be used to describe the relationship of one sine wave to another by using the terms “Leading” and “Lagging” to indicate the relationship between two sinusoidal waveforms of the same frequency, plotted onto the same reference axis. In our example above the two waveforms are *out-of-phase* by 30° . So we can correctly say that i lags v or we can say that v leads i by 30° depending upon which one we choose as our reference.

The relationship between the two waveforms and the resulting phase angle can be measured anywhere along the horizontal zero axis through which each waveform passes with the “same slope” direction either positive or negative.

In AC power circuits this ability to describe the relationship between a voltage and a current sine wave within the same circuit is very important and forms the bases of AC circuit analysis.

The Cosine Waveform

So we now know that if a waveform is “shifted” to the right or left of 0° when compared to another sine wave the expression for this waveform becomes $A_m \sin(\omega t \pm \Phi)$. But if the waveform crosses the horizontal zero axis with a positive going slope 90° or $\pi/2$ radians **before** the reference waveform, the waveform is called a **Cosine Waveform** and the expression becomes.

Cosine Expression

$$\sin(\omega t + 90^\circ) = \sin\left(\omega t + \frac{\pi}{2}\right) = \cos(\omega t)$$

The **Cosine Wave**, simply called “cos”, is as important as the sine wave in electrical engineering. The cosine wave has the same shape as its sine wave counterpart that is it is a sinusoidal function, but is shifted by $+90^\circ$ or one full quarter of a period ahead of it.

Phase Difference between a Sine wave and a Cosine wave

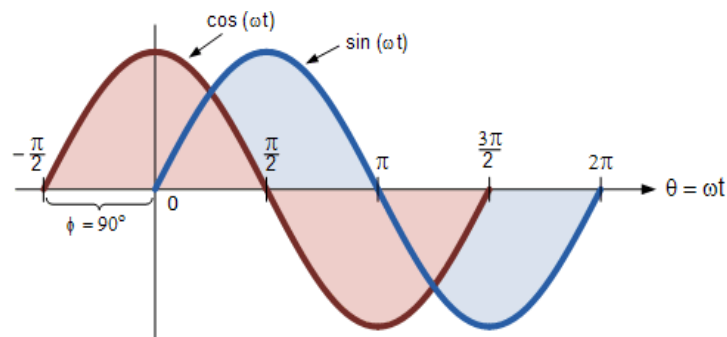

Alternatively, we can also say that a sine wave is a cosine wave that has been shifted in the other direction by -90° . Either way when dealing with sine waves or cosine waves with an angle the following rules will always apply.

Sine and Cosine Wave Relationships

$$\cos(\omega t + \phi) = \sin(\omega t + \phi + 90^\circ)$$

$$\sin(\omega t + \phi) = \cos(\omega t + \phi - 90^\circ)$$

When comparing two sinusoidal waveforms it more common to express their relationship as either a sine or cosine with positive going amplitudes and this is achieved using the following mathematical identities.

$$\sin(A \pm B) = \sin(A) \cos(B) \pm \cos(A) \sin(B)$$

$$\cos(A \pm B) = \cos(A) \cos(B) \mp \sin(A) \sin(B)$$

Therefore :

$$-\sin(\omega t) = \sin(\omega t \pm 180^\circ)$$

$$-\cos(\omega t) = \cos(\omega t \pm 180^\circ)$$

$$\pm \sin(\omega t) = \cos(\omega t \mp 90^\circ)$$

$$\pm \cos(\omega t) = \sin(\omega t \pm 90^\circ)$$

By using these relationships above we can convert any sinusoidal waveform with or without an angular or phase difference from either a sine wave into a cosine wave or vice versa.

4. Phasor Diagrams and Phasor Algebra

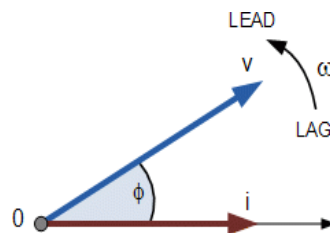

Phasor Diagrams are a graphical way of representing the magnitude and directional relationship between two or more alternating quantities

Sinusoidal waveforms of the same frequency can have a Phase Difference between themselves which represents the angular difference of the two sinusoidal waveforms. Also the terms “lead” and “lag” as well as “in-phase” and “out-of-phase” are commonly used to indicate the relationship of one waveform to the other with the generalized sinusoidal expression given as: $A_{(t)} = A_m \sin(\omega t \pm \Phi)$ representing the sinusoid in the time-domain form.

But when presented mathematically in this way it is sometimes difficult to visualise this angular or phasor difference between two or more sinusoidal waveforms. One way to overcome this problem is to represent the sinusoids graphically within the spacial or phasor-domain form by using **Phasor Diagrams**, and this is achieved by the rotating vector method.

Basically a rotating vector, simply called a “**Phasor**” is a scaled line whose length represents an AC quantity that has both magnitude (“peak amplitude”) and direction (“phase”) which is “frozen” at some point in time.

A phasor is a vector that has an arrow head at one end which signifies partly the maximum value of the vector quantity (V or I) and partly the end of the vector that rotates.

Generally, vectors are assumed to pivot at one end around a fixed zero point known as the “point of origin” while the arrowed end representing the quantity, freely rotates in an **anti-clockwise** direction at an angular velocity, (ω) of one full revolution for every cycle. This anti-clockwise rotation of the vector is considered to be a positive rotation. Likewise, a clockwise rotation is considered to be a negative rotation.

Although the both the terms vectors and phasors are used to describe a rotating line that itself has both magnitude and direction, the main difference between the two is that a vectors magnitude is the “peak value” of the sinusoid while a phasors magnitude is the “rms value” of the sinusoid. In both cases the phase angle and direction remains the same.

The phase of an alternating quantity at any instant in time can be represented by a phasor diagram, so phasor diagrams can be thought of as “functions of time”. A complete sine wave can be constructed by a single vector rotating at an angular velocity of $\omega = 2\pi f$, where f is the frequency of the waveform. Then a **Phasor** is a quantity that has both “Magnitude” and “Direction”.

Generally, when constructing a phasor diagram, angular velocity of a sine wave is always assumed to be: ω in rad/sec. Consider the phasor diagram below.

Phasor Diagram of a Sinusoidal Waveform

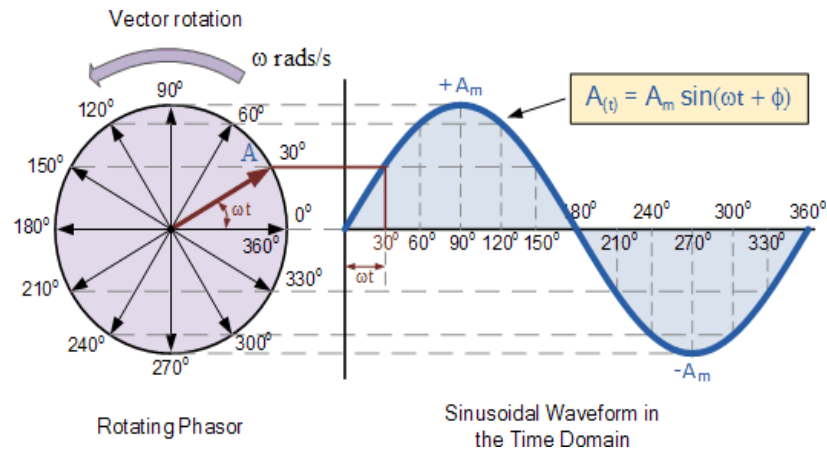

As the single vector rotates in an anti-clockwise direction, its tip at point A will rotate one complete revolution of 360° or 2π representing one complete cycle. If the length of its moving tip is transferred at different angular intervals in time to a graph as shown above, a sinusoidal waveform would be drawn starting at the left with zero time. Each position along the horizontal axis indicates the time that has elapsed since zero time, $t = 0$. When the vector is horizontal the tip of the vector represents the angles at 0° , 180° and at 360° .

Likewise, when the tip of the vector is vertical it represents the positive peak value, $(+A_m)$ at 90° or $\pi/2$ and the negative peak value, $(-A_m)$ at 270° or $3\pi/2$. Then the time axis of the waveform represents the angle either in degrees or radians through which the phasor has moved. So we can say that a phasor represent a scaled voltage or current value of a rotating vector which is “frozen” at some point in time, (t) and in our example above, this is at an angle of 30° .

Sometimes when we are analysing alternating waveforms we may need to know the position of the phasor, representing the Alternating Quantity at some particular instant in time especially when we want to compare two different waveforms on the same axis. For example, voltage and current. We have assumed in the waveform above that the waveform starts at time $t = 0$ with a corresponding phase angle in either degrees or radians.

But if a second waveform starts to the left or to the right of this zero point or we want to represent in phasor notation the relationship between the two waveforms then we will need to take into account this phase difference, Φ of the waveform. Consider the diagram below from the previous [Phase Difference](#) tutorial.

Phase Difference of a Sinusoidal Waveform

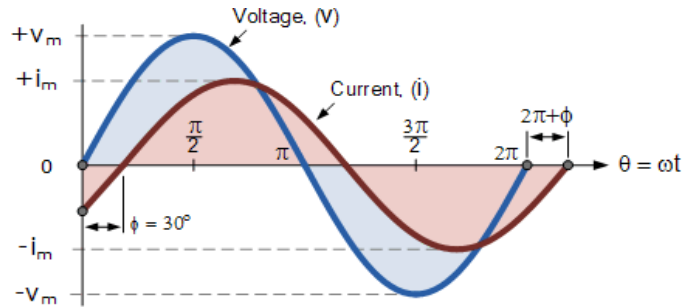

The generalised mathematical expression to define these two sinusoidal quantities will be written as:

$$v_{(t)} = V_m \sin(\omega t)$$

$$i_{(t)} = I_m \sin(\omega t - \phi)$$

The current, i is lagging the voltage, v by angle Φ and in our example above this is 30° . So the difference between the two phasors representing the two sinusoidal quantities is angle Φ and the resulting phasor diagram will be.

Phasor Diagram of a Sinusoidal Waveform

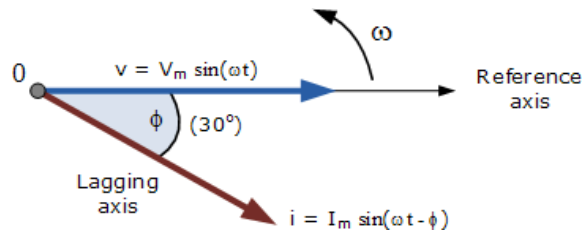

The phasor diagram is drawn corresponding to time zero ($t = 0$) on the horizontal axis. The lengths of the phasors are proportional to the values of the voltage, (V) and the current, (I) at the instant in time that the phasor diagram is drawn. The current phasor lags the voltage phasor by the angle, Φ , as the two phasors rotate in an *anticlockwise* direction as stated earlier, therefore the angle, Φ is also measured in the same anticlockwise direction.

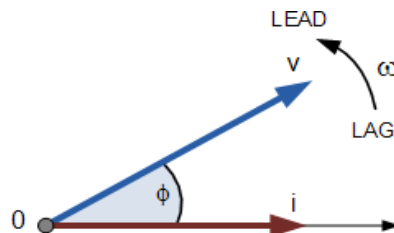

If however, the waveforms are frozen at time, $t = 30^\circ$, the corresponding phasor diagram would look like the one shown on the right. Once again the current phasor lags behind the voltage phasor as the two waveforms are of the same frequency.

However, as the current waveform is now crossing the horizontal zero axis line at this instant in time we can use the current phasor as our new reference and correctly say that the voltage phasor is “leading” the current phasor by angle, Φ . Either way, one phasor is designated as the *reference* phasor and all the other phasors will be either leading or lagging with respect to this reference.

Phasor Addition

Sometimes it is necessary when studying sinusoids to add together two alternating waveforms, for example in an AC series circuit, that are not in-phase with each other. If they are in-phase that is, there is no phase shift then they can be added together in the same way as DC values to find the algebraic sum of the two vectors. For example, if two voltages of say 50 volts and 25 volts respectively are together “in-phase”, they will add or sum together to form one voltage of 75 volts ($50 + 25$).

If however, they are not in-phase that is, they do not have identical directions or starting point then the phase angle between them needs to be taken into account so they are added together using phasor diagrams to determine their **Resultant Phasor** or **Vector Sum** by using the *parallelogram law*.

Consider two AC voltages, V_1 having a peak voltage of 20 volts, and V_2 having a peak voltage of 30 volts where V_1 leads V_2 by 60° . The total voltage, V_T of the two voltages can be found by firstly drawing a phasor diagram representing the two vectors and then constructing a parallelogram in which two of the sides are the voltages, V_1 and V_2 as shown below.

Phasor Addition of two Phasors

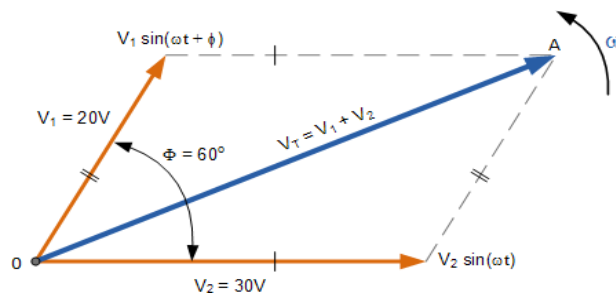

By drawing out the two phasors to scale onto graph paper, their phasor sum $V_1 + V_2$ can be easily found by measuring the length of the diagonal line, known as the “resultant r-vector”, from the zero point to the intersection of the construction lines O-A. The downside of this graphical method is that it is time consuming when drawing the phasors to scale.

Also, while this graphical method gives an answer which is accurate enough for most purposes, it may produce an error if not drawn accurately or correctly to scale. Then one way to ensure that the correct answer is always obtained is by an analytical method.

Mathematically we can add the two voltages together by firstly finding their “vertical” and “horizontal” directions, and from this we can then calculate both the “vertical” and “horizontal” components for the resultant “r vector”, V_T . This analytical method which uses the cosine and sine rule to find this resultant value is commonly called the **Rectangular Form**.

In the rectangular form, the phasor is divided up into a real part, x and an imaginary part, y forming the generalised expression $Z = x \pm jy$. (we will discuss this in more detail in the next tutorial). This then gives us a mathematical expression that represents both the magnitude and the phase of the sinusoidal voltage as:

Definition of a Complex Sinusoid

$$v = V_m \cos(\phi) + jV_m (\sin\phi)$$

So the addition of two vectors, A and B using the previous generalised expression is as follows:

$$A = x + jy \quad B = w + jz$$

$$A + B = (x + w) + j(y + z)$$

Phasor Addition using Rectangular Form

Voltage, V_2 of 30 volts points in the reference direction along the horizontal zero axis, then it has a horizontal component but no vertical component as follows.

- Horizontal Component = $30 \cos 0^\circ = 30$ volts
- Vertical Component = $30 \sin 0^\circ = 0$ volts
- This then gives us the rectangular expression for voltage V_2 of: $30 + j0$

Voltage, V_1 of 20 volts leads voltage, V_2 by 60° , then it has both horizontal and vertical components as follows.

- Horizontal Component = $20 \cos 60^\circ = 20 \times 0.5 = 10$ volts
- Vertical Component = $20 \sin 60^\circ = 20 \times 0.866 = 17.32$ volts
- This then gives us the rectangular expression for voltage V_1 of: $10 + j17.32$

The resultant voltage, V_T is found by adding together the horizontal and vertical components as follows.

- $V_{\text{Horizontal}} = \text{sum of real parts of } V_1 \text{ and } V_2 = 30 + 10 = 40$ volts
- $V_{\text{Vertical}} = \text{sum of imaginary parts of } V_1 \text{ and } V_2 = 0 + 17.32 = 17.32$ volts

Now that both the real and imaginary values have been found the magnitude of voltage, V_T is determined by simply using **Pythagoras’s Theorem** for a 90° triangle as follows.

$$V_T = \sqrt{\left(\begin{matrix} \text{Real or Horizontal} \\ \text{Component} \end{matrix}\right)^2 + \left(\begin{matrix} \text{Imaginary or Vertical} \\ \text{Component} \end{matrix}\right)^2}$$

$$V_T = \sqrt{40^2 + 17.32^2}$$

$$\therefore V_T = 43.6 \text{ volts}$$

Then the resulting phasor diagram will be:

Resultant Value of V_T

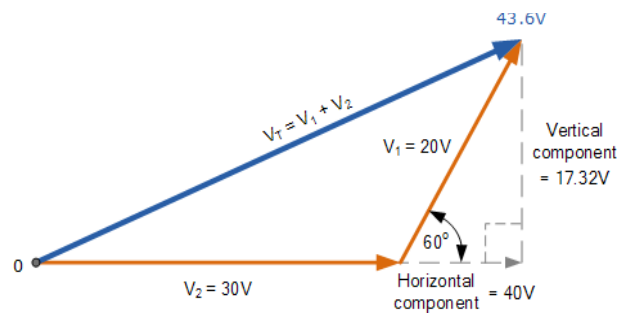

Phasor Subtraction

Phasor subtraction is very similar to the above rectangular method of addition, except this time the vector difference is the other diagonal of the parallelogram between the two voltages of V_1 and V_2 as shown.

Vector Subtraction of two Phasors

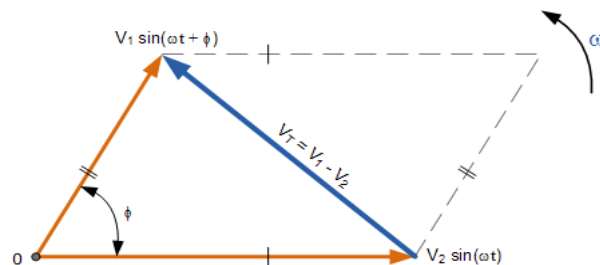

This time instead of “adding” together both the horizontal and vertical components we take them away, subtraction.

$$A = x + jy \quad B = w + jz$$

$$A - B = (x - w) + j(y - z)$$

The 3-Phase Phasor Diagram

Previously we have only looked at single-phase AC waveforms where a single multi-turn coil rotates within a magnetic field. But if three identical coils each with the same number of coil turns are placed at an electrical angle of 120° to each other on the same rotor shaft, a three-phase voltage supply would be generated.

A balanced three-phase voltage supply consists of three individual sinusoidal voltages that are all equal in magnitude and frequency but are out-of-phase with each other by exactly 120° electrical degrees.

Standard practice is to colour code the three phases as Red, Yellow and Blue to identify each individual phase with the red phase as the reference phase. The normal sequence of rotation for a three phase supply is Red followed by Yellow followed by Blue, (R, Y, B).

As with the single-phase phasors above, the phasors representing a three-phase system also rotate in an anti-clockwise direction around a central point as indicated by the arrow marked ω in rad/s. The phasors for a three-phase balanced star or delta connected system are shown below.

Three-phase Phasor Diagram

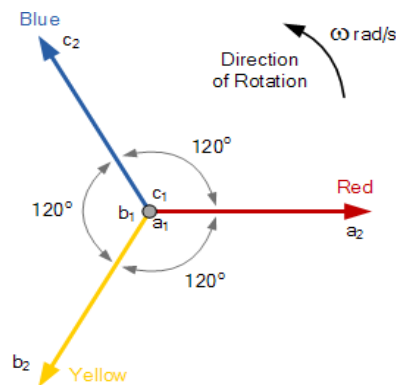

The phase voltages are all equal in magnitude but only differ in their phase angle. The three windings of the coils are connected together at points, a_1 , b_1 and c_1 to produce a common neutral connection for the three individual phases. Then if the red phase is taken as the reference phase each individual phase voltage can be defined with respect to the common neutral as.

Three-phase Voltage Equations

$$\text{Red Phase: } V_{RN} = V_m \sin\theta$$

$$\text{Yellow Phase: } V_{YN} = V_m \sin(\theta - 120^\circ)$$

$$\text{Blue Phase: } V_{BN} = V_m \sin(\theta - 240^\circ)$$

or

$$V_{BN} = V_m \sin(\theta + 120^\circ)$$

If the red phase voltage, V_{RN} is taken as the reference voltage as stated earlier then the phase sequence will be $R - Y - B$ so the voltage in the yellow phase lags V_{RN} by 120° , and the voltage in the blue phase lags V_{YN} also by 120° . But we can also say the blue phase voltage, V_{BN} leads the red phase voltage, V_{RN} by 120° .

One final point about a three-phase system. As the three individual sinusoidal voltages have a fixed relationship between each other of 120° they are said to be “balanced” therefore, in a set of balanced three phase voltages their phasor sum will always be zero as: $V_a + V_b + V_c = 0$

Phasor Diagram Summary

Then to summarize this tutorial about **Phasor Diagrams** a little.

In their simplest terms, phasor diagrams are a projection of a rotating vector onto a horizontal axis which represents the instantaneous value. As a phasor diagram can be drawn to represent any instant of time and therefore any angle, the reference phasor of an alternating quantity is always drawn along the positive x-axis direction.

- Vectors, Phasors and **Phasor Diagrams** ONLY apply to sinusoidal AC alternating quantities.
- A Phasor Diagram can be used to represent two or more stationary sinusoidal quantities at any instant in time.
- Generally the reference phasor is drawn along the horizontal axis and at that instant in time the other phasors are drawn. All phasors are drawn referenced to the horizontal zero axis.
- Phasor diagrams can be drawn to represent more than two sinusoids. They can be either voltage, current or some other alternating quantity but the frequency of all of them **must be the same**.
- All phasors are drawn rotating in an anticlockwise direction. All the phasors ahead of the reference phasor are said to be “leading” while all the phasors behind the reference phasor are said to be “lagging”.
- Generally, the length of a phasor represents the r.m.s. value of the sinusoidal quantity rather than its maximum value.
- Sinusoids of different frequencies cannot be represented on the same phasor diagram due to the different speed of the vectors. At any instant in time the phase angle between them will be different.

- Two or more vectors can be added or subtracted together and become a single vector, called a **Resultant Vector**.
- The horizontal side of a vector is equal to the real or “x” vector. The vertical side of a vector is equal to the imaginary or “y” vector. The hypotenuse of the resultant right angled triangle is equivalent to the “r” vector.
- In a three-phase balanced system each individual phasor is displaced by 120° .

UNIT IV

ELECTRO MAGNETIC CIRCUIT

OBJECTIVES:

When electric current passes through current carrying conductor or coil then a magnetic field is produced around it. The working of appliances like electric bell is based on this principle. As opposite to this if a continuous change in magnetic field is produced then electric current can be produced. This is how electricity and magnetism have become synonymous today. After studying this lesson, you will be able to:

- Explain the concept of magnetic field and state the properties of lines of magnetic force;
- Infer that when electricity flows through a conductor, magnetic field is produced around it;
- Explain the force experienced by a current carrying conductor placed in a magnetic field;
- Describe electromagnetic induction and Its importance in different aspects of daily life;

CONCEPT OF ELECTROMAGNETIC FIELD PRODUCED BY FLOW OF ELECTRIC CURRENT-

4.1.1 Concept of Electric Charge

Electric Charge is the fundamental property of matter that develop electrical influence. Electric charge can be positive or negative, stationary or moving one. Electric charge is the that property of matter due to which it exhibits electric, magnetic and electromagnetic effects.

Properties of electric charge:

- Total electric charge in an isolated system remains constant.
- Electric charge is a scalar quantity and is always associated with mass.

- Electric charge at rest causes an electric field, while moving at a constant speed it causes a magnetic field and when accelerated it emits electromagnetic waves.
- Like charges repel each other and unlike charges attract each other.
- **SI unit** of charge is **coulomb (C)**.
- **One coulomb** is the quantity of charge that has passed through a conductor carrying line ampere current in one second.

Coulomb's Law:

Coulomb's law states that "the magnitude of the electric force between two charges is directly proportional to the product of the two charges and inversely proportional to the square of the distance between them."

Let two charges **q1** and **q2** present in vacuum at points A and B at a distance "**d**" as shown in **fig 4.1**.

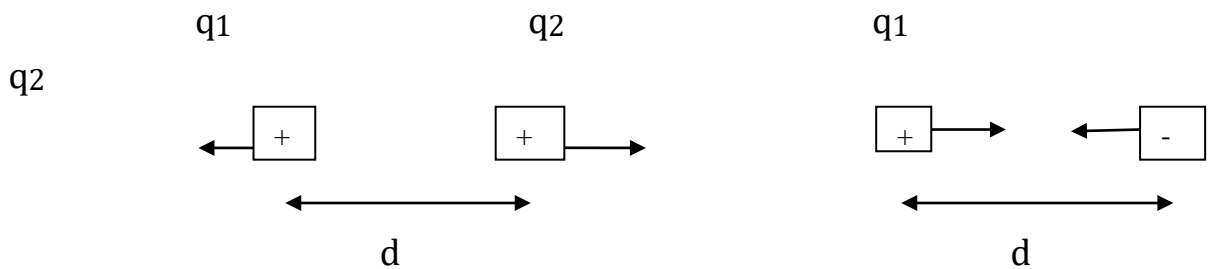

Fig: 4.1 a) Repulsion

b) Attraction

The force between two charges is given by:

$$F \propto q_1 \cdot q_2 / d^2 \quad \dots\dots(1)$$

$$F = K q_1 q_2 / d^2 \dots\dots\dots(2)$$

Where K is constant whose magnitude depends on the medium in which charges are kept.

$$K = 1 / 4\pi \epsilon_0 \epsilon_r$$

Where ϵ_0 = absolute permittivity of vacuum = 8.854×10^{-12} F/m

ϵ_r = relative permittivity of medium for vacuum or air and is equal to 1.

$$F = \frac{q_1 \cdot q_2}{4\pi\epsilon_0 \epsilon_r d^2} \quad \text{---(3)}$$

$$F = \frac{q_1 \cdot q_2}{4\pi \cdot 8.854 \times 10^{-12} \epsilon_r d^2}$$

$$F = 9 \times 10^9 \frac{q_1 \cdot q_2}{\epsilon_r d^2} \text{Newtons (in medium)}$$

$$F = 9 \times 10^9 \frac{q_1 \cdot q_2}{d^2} \text{Newtons (in air) ---(4)}$$

When q_1 and q_2 are equal then we can determine the unit of charge.

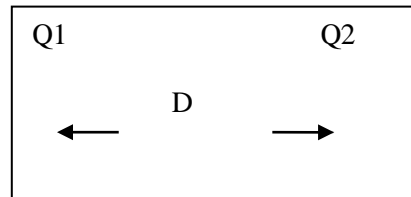

Fig 4.2 Charge in medium

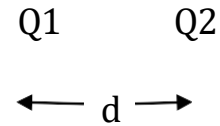

Fig 4.3 Charge in air

If in equation (4) $Q_1 = Q_2 = Q$, and $d = 1\text{m}$
 $F = 9 \times 10^9 \text{Newtons}$
 Then $Q^2 = 1$
 Or $Q = \pm \sqrt{1} \text{ coulombs}$

Hence 1 coulomb is that charge when placed at a distance of 1m from equal and similar charge, repels it with a force of $9 \times 10^9 \text{Newtons}$.

The branch of science associated with the study of effects of stationary charges is called electrostatics.

4.1.2 Concept of Magnetism

A force of attraction or repulsion that acts at a distance and caused due to a magnetic field is called **magnetism**.

The branch of science concerned with the forces that occur between electricity charged particles is called **electromagnetism**.

Two aspects of electromagnetism are:

- i) Electricity**
- ii) Magnetism**

The magnetic field is a force created by moving electric charges and magnetic dipoles. It is a vector field. The magnetic force is force of attraction or repulsion between electrically charged particles because of their motion. **Electricity and magnetism** are closely related. spinning magnets cause an electric current to flow and flowing electron produces a

magnetic field. The **relationship** between electricity and magnetism is called **electromagnetism**. Magnets are artificial magnets and natural magnets. Artificial magnets were formerly made by rubbing iron with a natural magnet. The iron is behaving as a natural magnet is known as magnetite (Fe_3O_4). A piece of magnetite is called a natural magnet. Permanent magnets have the property of retaining magnetism indefinitely and they require no electric aid to magnetize like existing coils (ampere turns).

Ampere Turns

Ampere turns is the product of current I flowing through a coil in amperes and the number of turns of coil.

It is represented by **AT**. It is the **magneto motive force (m.m.f.)** produced by the coil.

Artificial magnets are made by process of magnetization. A soft iron piece if similarly magnetized will remain its magnetism only for a small time.

Magnetic Material

Substances which are attracted by a magnet are called magnetic materials. Iron, steel and some of their alloys are superior to all other metals. Cobalt, nickel and some of their alloys possess certain magnetic properties.

4.1.3 MAGNETIC FIELD

Keep a small magnetic needle near a bar magnet. The magnetic needle rotates and stops in a particular direction only. This shows that a force acts on the magnetic needle that makes it rotate and rest in a particular direction only. This force is called torque.

The region around the magnet where the force on the magnetic needle occurs and the needle stops at a specific direction, is called a magnetic field. The direction of magnetic field is represented by magnetic line of forces. As shown in Fig.4.4, the direction of magnetic needle changes continuously and it takes the curved path while moving from north to south. This curved path is known as magnetic line of forces. Tangent line draw a tiny point on magnetic line of force, represent the direction of magnetic field at that point.

If the lines along which the iron fillings set themselves near the ends of the bar magnet are extended into the magnet, they would be seen to concentrate themselves in two particular regions near each end of the

magnet. These regions are called as poles of the magnet.

The imaginary line joining the two poles of a magnet is known as magnetic – axis and a plane taken at right angles to the magnetic axis and through a point midway between the poles, is called the neutral zone or equator of the magnet.

These magnetic lines of forces have following properties:

1. Magnetic line of forces always starts from North Pole and end at South Pole of the magnet.
2. These lines of forces never intersect each other.
3. Near the poles magnetic lines are very near to each other which shows that magnetic field at the poles is stronger as compare to other parts.
4. They seek the path of least resistance between opposite magnetic poles.

In a single

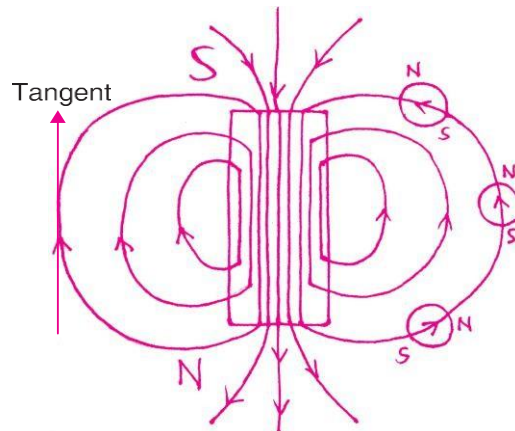

Fig. 4.3

bar magnet as shown to the right, they attempt to form closed loops from pole to pole.

5. They all have the same strength.
6. Their density decreases (they spread out) when they move from an area of higher permeability to an area of lower permeability

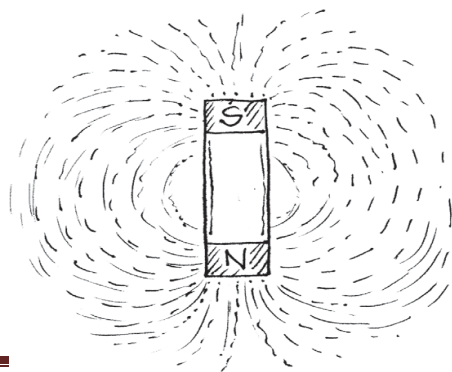

Fig. 4.4

Our Earth itself acts as a giant magnet with south magnetic pole somewhere in the Arctic and north magnetic pole in Antarctic. The Earth also behaves like a bar magnet. Its hot liquid center core contains iron and as it moves, it creates an electric current that cause a magnetic field around the Earth. The Earth has a north and south magnetic pole. These poles are not same with the geographic north and south poles on a map and tilted at an angle of 11.3 degree with respect to it. Due to this, if a magnetic needle is suspended freely, it rests in the north- south direction and is useful for navigation.

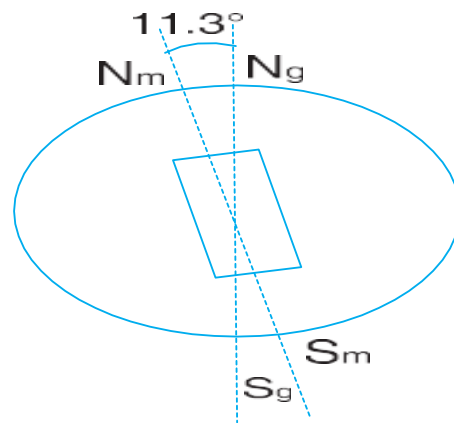

Fig 4.5.

4.1.4 1Magnetic Flux

Magnetic flux is a measurement of the total magnetic field which passes through a given area. It is a useful tool for helping describe the effects of the magnetic force on something occupying a given area. The measurement of magnetic flux is tied to the particular area chosen. We can choose to make the area any size we want and orient it in any way relative to the magnetic field.

If we use the field-line picture of a magnetic field then every field line passing through the given area contributes some magnetic flux. The angle at which the field line intersects the area is also important. A field line passing through at a glancing angle will only contribute a small component of the field to the magnetic flux. When calculating the magnetic flux, we include only the component of the magnetic field vector

which is normal to our test area.

If we choose a simple flat surface with area A as our test area and there is an angle θ between the normal to the surface and a magnetic field vector (magnitude B) then the magnetic flux is,

$$\Phi_B = B A \cos \theta$$

In the case that the surface is perpendicular to the field then the angle is zero and the magnetic flux is simply $B \cdot A$. Figure 1 shows an example of a flat test area at two different angles to a magnetic field and the resulting magnetic flux.

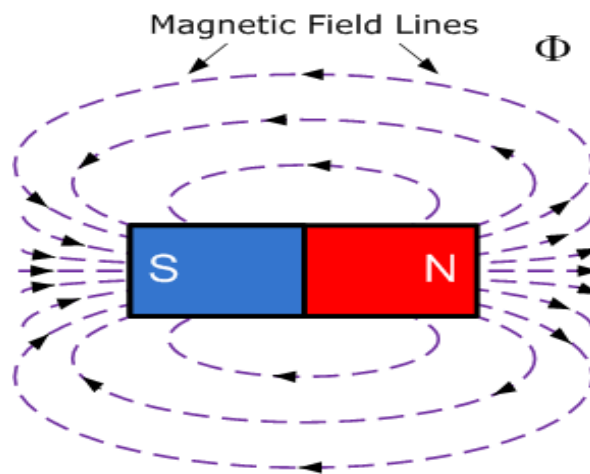

Fig 4.6

4.1.4 The Magnitude of Magnetism

We now know that the lines of force or more commonly the magnetic flux around a magnetic material is given the Greek symbol, Phi, (Φ) with the unit of flux being the Weber, (Wb) after Wilhelm Eduard Weber. But the number of lines of force within a given unit area is called the “Flux Density” and since flux (Φ) is measured in (Wb) and area (A) in meters squared, (m^2), flux density is therefore measured in Weber/Metre² or (Wb/ m^2) and is given the symbol B .

However, when referring to flux density in magnetism, flux density is given the unit of the Tesla after Nikola Tesla so therefore one Wb/ m^2 is equal to one Tesla, $1\text{Wb}/m^2 = 1\text{T}$. Flux density is proportional to the lines of force and inversely proportional to area so we can define Flux

Density as:

4.1.5 Magnetic Flux Density

$$\text{Magnetic Flux Density, (tesla)} = \frac{\text{Magnetic Flux, (weber)}}{\text{Area, (m}^2\text{)}}$$

The symbol for magnetic flux density is B and the unit of magnetic flux density is the Tesla, T.

$$B = \frac{\Phi}{A} \quad \text{in Teslas}$$

It is important to remember that all calculations for flux density are done in the same units, e.g., flux in Weber, area in m² and flux density in Tesla.

4.1.6 ELECTROMAGNETISM

Electromagnetism is the science that deals with the phenomena associated with electric and magnetic fields and their interaction with each other, with electric charges and currents.

An electromagnet is a type of magnet in which magnetic field is produced by the flow of electric current. For making electromagnet take a piece of paper and give a cylindrical shape.

Make several turns of a copper wire over this from one end to the other. This is called solenoid along thin loop of wire. When the ends of the copper wires are attached to the ends of a battery (+ and -) current starts flowing through the coil which starts functioning as a bar magnet.

When the flow of current is stopped from the battery, then, its magnetic property ceases. If the +ve and -ve terminals of the battery are reversed, then the poles of the magnet are also reversed.

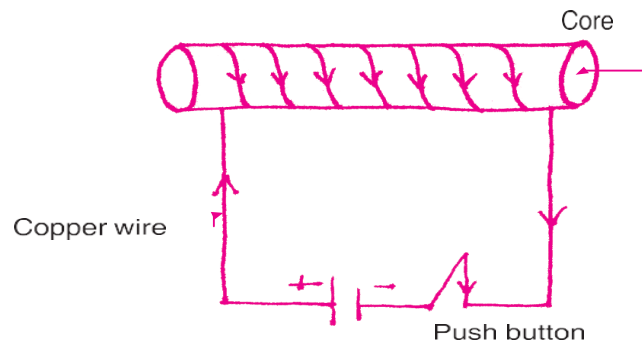

Fig.4 .8 Solenoid

For increasing the magnetic field, puts of the iron like iron nails inside the core. So Current carry solenoid with soft iron core inside it forms an electromagnet. Electromagnet may be made as strong as one may desire. Electromagnet are widely used as a component in electrical devices such as motor, generator, electrical bells MRI machine etc. Beside that strong electromagnet are also being used in brake system of the superfast train in the world, in the cyclotrons and in mega experiments like experiment at CERN laboratory at Geneva.

4.1.7 MAGNETIC FIELD AROUND THE CURRENT CARRYING WIRE

If an electric current is made to flow in a wire, magnetic field produce around it. For seeing this takes a conducting wire (like copper). Now with the help of connecting wires attach this to the two ends of a battery. Keep a magnetic needle parallel to the conducting copper wire as shown in Fig. 4.9(a). When the circuit is complete the magnetic needle shows deflection. This shows that when electric current flows through a conductor, magnetic field is produced around the conductor. If the current is increased, there is greater amount of deflection. If the direction of flow of electric current is changed (by reversing the end of the battery) the direction of deflection in the magnetic needle is also reversed. If the current flow is stopped the deflection in the magnetic needle also ceases. Thus, magnetic field is an effect of flow of electric current through conducting wire. In the year 1820 a scientist from Denmark named H.C. Oersted observed this effect for the first time.

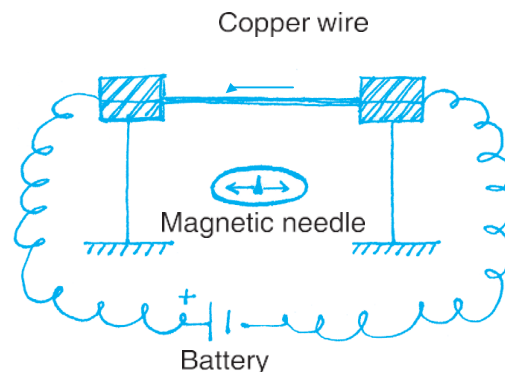

Fig.4. (a)



(b)

The principle of the magnetic effect of electric current used in many appliances like motor etc.

4.1.8 Magnetic field Due to a Current Carrying Conductor

A current carrying straight conductor has magnetic field in the form of concentric circles around it. Magnetic field of current carrying straight conductor can be shown by magnetic field lines.

The magnetic field of an infinitely long straight wire can be obtained by applying Ampere's law. The expression for the magnetic field is

$$B = \frac{\mu_0 I}{2\pi r}$$

Where, I is the current

r is the radial distance

The permeability of free space is

$$\mu_0 = 4\pi \times 10^{-7} \text{ T} \cdot \text{m} / \text{A}$$

The direction of magnetic field through a current carrying conductor depends upon the direction of flow of electric current. The direction of magnetic field gets reversed in case of a change in the direction of electric current.

Let a current carrying conductor be suspended vertically and the electric current is flowing from south to north. In this case, the direction of magnetic field will be anticlockwise. If the current is flowing from north to south, the direction of magnetic field will be clockwise.

Right Hand Thumb Rule

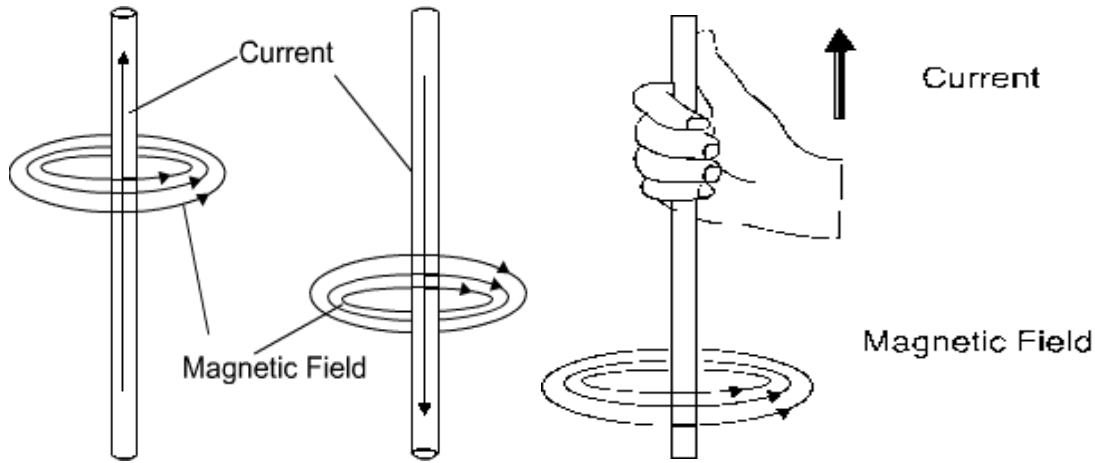

Fig 4.10 (a)

(b)

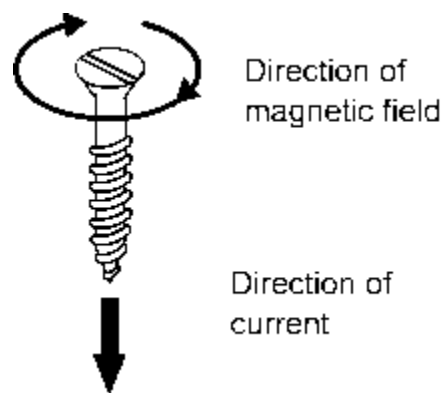

Fig 4.11

The direction of magnetic field, in relation to direction of electric current through a straight conductor can be depicted by using the Right-Hand Thumb Rule. It is also known as Maxwell's Corkscrew Rule.

If a current carrying conductor is held by right hand, keeping the thumb straight and if the direction of electric current is in the direction of thumb, then the direction of wrapping of other fingers will show the direction of magnetic field.

As per Maxwell's corkscrew rule, if the direction of forward movement of screw shows the direction of current, then the direction of rotation of screw shows the direction of magnetic field.

Properties of Magnetic Field:

The magnitude of magnetic field increases with increase in electric current and decreases with decrease in electric current.

The magnitude of magnetic field, produced by electric current, decreases with increase in distance and vice-versa. The size of concentric circles of magnetic field lines increases with distance from the conductor, which shows that magnetic field decreases with distance.

Magnetic field lines are always parallel to each other.

No two field lines cross each other.

4.1.9 Magnetic field due to currents in two parallel conductors

From book

4.1.10 Magnetic Field Lines in a Current-Carrying Circular Loop

We know that the magnetic field lines have a circular pattern when an electric current is passed through a straight wire. However, when a wire is bent into a circular loop and an electric current is passed through it, the nature of the magnetic field lines changes as shown in the below illustration.

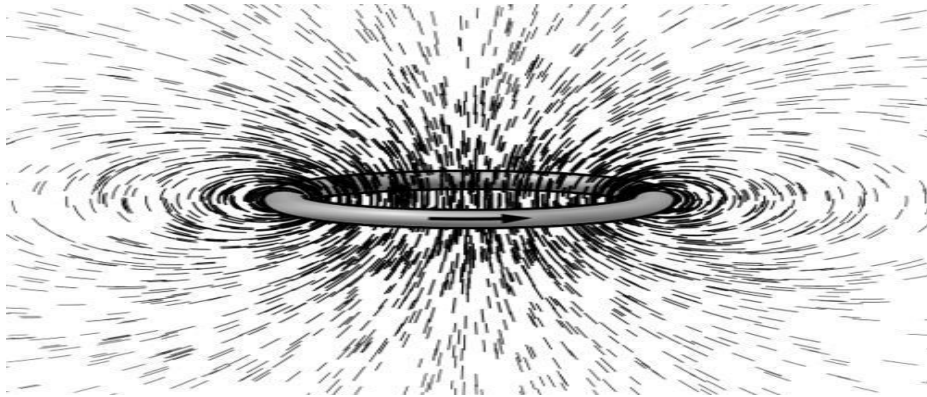

Fi: 4.14

Suppose, we take a circular coil with multiple turns, place it halfway through a sheet of cardboard, and connect it in series with the ammeter, battery, plug key, and a rheostat. Now sprinkle some iron fillings over the cardboard and pass an electric current through the wire by switching on the plug key. The iron fillings present on the cardboard will align in a specific pattern, proving the presence of a magnetic field.

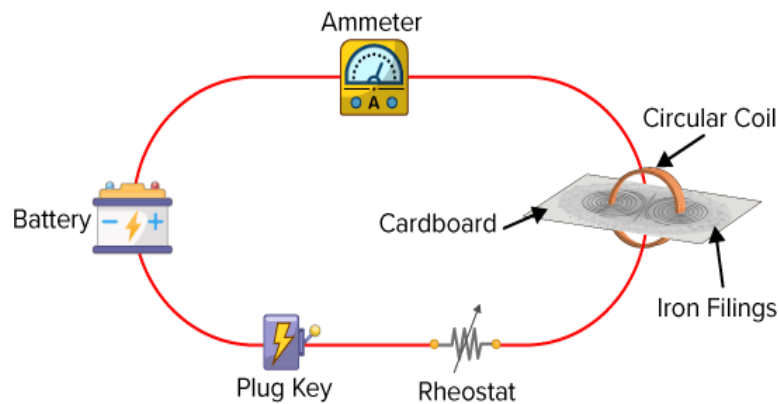

Fig:4.15

The magnetic field lines are concentric circles at every point of a current-carrying circular loop

The magnetic field lines are straight at the center of the loop and the lines of force are in the same direction

The magnetic field lines at the center of the loop are perpendicular to the plane of the loop carrying current

At the center of the loop, the intensity of the magnetic field is maximum while the magnetic field intensity decreases as we move away from the center of the loop

Each segment of the circular loop carrying current produces magnetic field lines in the same direction within the loop

The direction of the magnetic field of every section of the circular loop can be found by using the right-hand thumb rule. As per the rule, If you are holding a current-carrying straight conductor in your right hand such that the thumb points towards the direction of current. Then your fingers will wrap around the conductor in the direction of the field lines of the magnetic field. That means when the electric current is in the upward direction around the axis of the circular conductor, the magnetic field lines are in an anti-clockwise direction while with the downward flow of electric current, the magnetic field lines are in a clockwise direction.

The magnitude of magnetic field is directly proportional to magnitude of current flowing through the coil and is inversely proportional to the radius of coil.

$$B \propto I$$

$$B \propto 1/r$$

4.1.11 Magnetic Field due to Solenoid

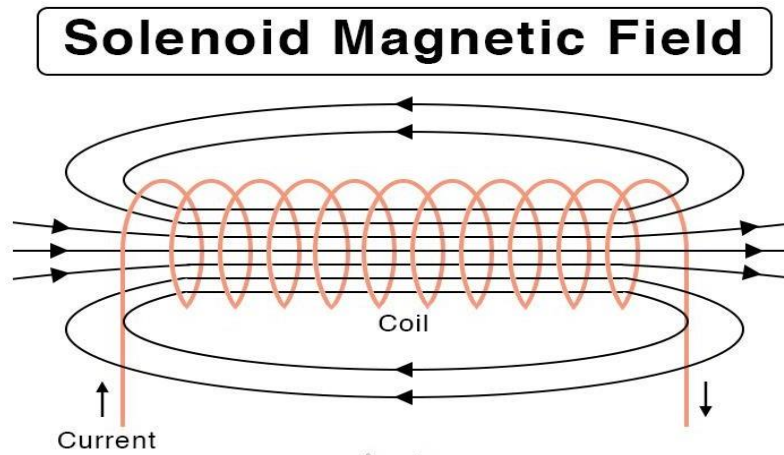

Fig:4.16

A solenoid is a coil of wire designed to create a strong magnetic field inside the coil. By wrapping the same wire many times around a cylinder, the magnetic field due to the wires can become quite strong. If a current is passed through a solenoid, it produces a magnetic field. The lines of force run approximately parallel to the axis of the solenoid until they reach the ends where they begin to diverge. The number of turns N refers to the number of loops the solenoid has. More loops will bring about a stronger magnetic field. The formula for the field inside the solenoid is

$$B = I N / L$$

Where, B is the magnetic field

I is the current in the coil

N is the number of turns in the solenoid

L is the length of the coil

This formula can be accepted on faith; or it can be derived using **Ampere's law** as follows. Look at a cross section of the solenoid. The magnetic field outside a solenoid is:

$$B = \mu_0 NI$$

Since the field outside the solenoid is comparatively less than that it is present inside where, we can consider it as zero as the length of the solenoid increases, and hence $B = 0$.

Total flux of solenoid:

In a long solenoid the flux density is uniform over the entire cross sectional area A so that the total flux

$$\phi = B.A = (I N / L). A \quad \text{---(in air)}$$

$$\phi = B.A = (I N / L). A \quad \text{---(in medium)}$$

The presence of charges in space or in a medium creates an electric field, similarly the flow of current in a conductor sets up a magnetic field.

Electric field is represented by electric flux lines, magnetic flux lines are used to describe the magnetic field. The path of the magnetic flux lines is called the magnetic circuit. Just as a flow of current in the electric circuit requires the presence of an electromotive force, so the production of magnetic flux requires the presence of magneto-motive force (mmf).

Properties related to magnetic flux.**(a) Flux density (B):**

The magnetic flux lines start and end in such a way that they form closed loops. Weber (Wb) is the unit of magnetic flux (Φ). Flux density (B) is the flux per unit area. Tesla (T) or Wb/m² is the unit of flux density.

$$B = \frac{\Phi}{A} \text{ Wb/m}^2 \text{ or Tesla}$$

where B is a quantity called magnetic flux density in Tesla, Φ is the total flux in Weber and A is the area perpendicular to the lines in m².

(b) Magneto-motive force MMF (\mathcal{F}):

A measure of the ability of a coil to produce a flux is called the magneto-motive force. It may be considered as a magnetic pressure, just as emf is considered as an electric pressure. A coil with N turns which is carrying a current of I amperes constitutes a magnetic circuit and produces an mmf of NI ampere turns. The source of flux (Φ) in the magnetic circuit is the mmf. The flux produced in the circuit depends on mmf and the length of the circuit.

(c) Magnetic field strength / Field Strength(H):

The magnetic field strength of a circuit is given by the mmf per unit length.

$$H = \frac{\mathcal{F}}{l} = \frac{NI}{l} \text{ AT/m}$$

The magnetic flux density (B) and its intensity (field strength) in a medium can be related by the following equation

$$B = \mu H$$

Where,

$\mu = \mu_0 \mu_r$ is the permeability of the medium in Henrys/meter (H/m),
 μ_0 = absolute permeability of free space and is equal to $4\pi \times 10^{-7}$ H/m
 and
 μ_r = relative permeability of the medium.

Relative permeability is a non-dimensional numeric which indicates the degree to which the medium is a better conductor of magnetic flux as compared to free space. The value of $\mu_r = 1$ for air and non-magnetic materials. It varies from 1,000 to 10,000 for some types of ferro-magnetic materials.

(d) Reluctance (S):

It is the property of the medium which opposes the passage of magnetic flux. The magnetic reluctance is analogous to resistance in the electric circuit. Its unit is AT/Wb. Air has a much higher reluctance than does iron or steel. For this reason, Magnetic Circuit Analysis used in electrical machines are designed with very small air gaps.

According to definition, reluctance = mmf/flux

The reciprocal of reluctance is known as permeance $1/R = \Phi/\zeta$

Thus, reluctance is a measure of the opposition offered by a magnetic circuit to the, setting up of the flux. The reluctance of the magnetic circuit is given by $R = l/\mu a$.

where l is the length, a is the cross-sectional area of the Magnetic Circuit Analysis and it is the permeability of the medium.

From the above equations

$$\frac{1}{\mu} \cdot \frac{l}{a} = \frac{\zeta}{\phi}$$

$$\frac{\zeta}{1} = \frac{1}{\mu} \cdot \frac{\phi}{a}$$

$$\frac{NI}{l} = \frac{1}{\mu} \cdot B$$

$$H = \frac{1}{\mu} \cdot B$$

$$B = \mu H$$

Permeance(P)

It is reciprocal of reluctance and it is the readiness with which magnetic flux is developed. It is analogous to conductance in an electric circuit. Its unit is weber per ampere turn.

$$\text{Thus } P = \Phi / \zeta \text{ (Flux /m.m.f.)}$$

4.1.15 Analogy between Magnetic and Electric Circuits:

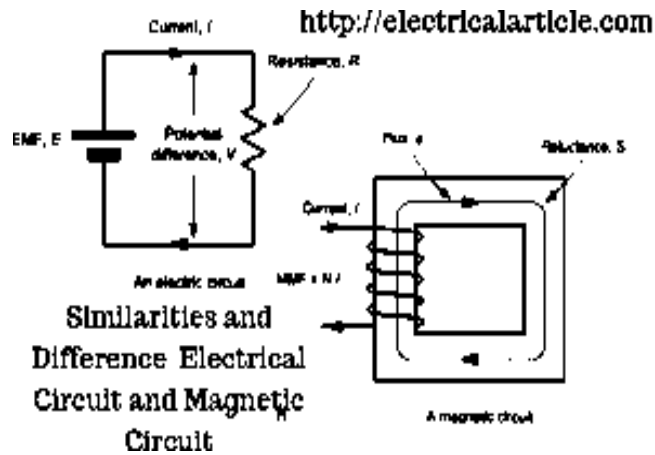

Similarities:

Similarities between electrical and magnetic circuits are given below.

Magnetic circuit	Electric circuit
The close path for the magnetic flux is called magnetic circuit.	The close path for the electric current is called electric circuit.
The number of magnetic lines of force decide the magnetic flux.	Flow of electron decide the current passing through the conductor.
Flux (Φ) = MMF/Reluctance	Current (I) = EMF/Resistance

MMF is the driving force in the magnetic circuit. The unit of MMF is ampere-turns (AT).	EMF is the driving force in the electric circuit. The unit of EMF is volts (V).
Reluctance (S) opposed by the magnetic path to the flux. The unit of reluctance is AT/Wb.	Resistance (R) oppose the flow of current. The unit of resistance is ohm (Ω).
Flux (ϕ) measured in weber (Wb).	Current (I) measured in Ampere (A).
MMF measured in Amp Turns (AT).	EMF measured in Volts (V).
Permanence = $1/\text{Reluctance} = 1/S$	Conductance = $1/\text{Resistance} = 1/R$
Permeability (μ)	Conductivity (σ)
Reluctivity	Resistivity
Flux Density (B) = ϕ/A (Wb/m²)	Current Density (J) = I / A (A/m²)
Magnetic Intensity (H) = NI/L (AT/m)	Electric Intensity (E) = V/d (V/m)
Kirchhoff MMF Law and Flux Law is applicable to the Magnetic Flux.	Kirchhoff Current Law (KCL) and Kirchhoff Voltage Law (KVL) is applicable to the electrical circuit.

Dissimilarities:

There are few dissimilarities between the two circuits which are listed below:

Magnetic circuit	Electric circuit
There is no magnetic insulator as flux can pass through all the materials, even through the air as well.	There are many materials which used as insulators. From which current cannot pass. i.e., air, PVC, glass, synthetic resin

For magnetic flux there is no perfect insulators.	etc.
Magnetic flux does not flow but it set up in the magnetic circuit.	The electric current actually flows in an electric circuit.
At constant temperature, the reluctance (S) of a magnetic circuit is not constant but varies with μ_r.	At constant temperature, the resistance of an electric circuit is constant as its value depends on resistivity which is almost constant.
Once magnetic flux is setup in a magnetic circuit, no energy needed.	Energy needed as long as current flows through electric circuit.

4.2.1 Faraday's Laws of Electromagnetic Induction

Faraday's law of electromagnetic induction (referred to as Faraday's law) is a basic law of electromagnetism predicting how a magnetic field will interact with an electric circuit to produce an electromotive force (EMF). This phenomenon is known as electromagnetic induction.

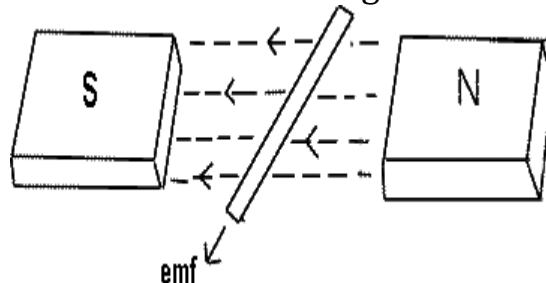

Faraday's law states that a current will be induced in a conductor which is exposed to a changing magnetic field. Lenz's law of electromagnetic induction states that the direction of this induced current will be such that the magnetic field created by the induced current *opposes* the initial changing magnetic field which produced it. The direction of this current flow can be determined using Fleming's right-hand rule.

Faraday's law of induction explains the working principle of transformers, motors, generators, and inductors. The law is named after Michael Faraday, who performed an experiment with a magnet and a coil. During Faraday's experiment, he discovered how EMF is induced in a coil when the flux passing through the coil changes.

Faraday's First Law

Any change in the magnetic field of a coil of wire will cause an emf to be induced in the coil. This emf induced is called induced emf and if the conductor circuit is closed, the current will also circulate through the circuit and this current is called induced current.

Method to change the magnetic field:

By moving a magnet towards or away from the coil

By moving the coil into or out of the magnetic field

By changing the area of a coil placed in the magnetic field

By rotating the coil relative to the magnet

Faraday's Second Law

It states that the magnitude of emf induced in the coil is equal to the rate of change of flux that linkages with the coil. The flux linkage of the coil is the product of the number of turns in the coil and flux associated with the coil.

Faraday Law Formula

Consider, a magnet is approaching towards a coil. Here we consider two instants at time T_1 and time T_2 .

Flux linkage with the coil at time, $T_1 = N\Phi_1$

Flux linkage with the coil at time, $T_2 = N\Phi_2$

Change in flux linkage $(\Phi_2 - \Phi_1)$

Let this change in flux linkage be, $\Phi = \Phi_2 - \Phi_1$

So, the Change in flux linkage $N\Phi$

Now the rate of change of flux linkage/t

Take derivative on right-hand side we will get $N \frac{d\Phi}{dt}$

The rate of change of flux linkage

$$E = N \frac{d\phi}{dt}$$

But according to Faraday's law of electromagnetic induction, the rate of change of flux linkage is equal to induced emf.

$$E = - N \frac{d\phi}{dt}$$

Considering Lenz's Law.

Where:

Flux Φ in Wb = B.A

B = magnetic field strength

A = area of the coil

How To Increase EMF Induced in a Coil

By increasing the number of turns in the coil i.e N, from the formulae derived above it is easily seen that if the number of turns in a coil is increased, the induced emf also gets increased.

By increasing magnetic field strength i.e B surrounding the coil- Mathematically, if magnetic field increases, flux increases and if flux increases emf induced will also get increased. Theoretically, if the coil is passed through a stronger magnetic field, there will be more lines of force for the coil to cut and hence there will be more emf induced.

By increasing the speed of the relative motion between the coil and the magnet - If the relative speed between the coil and magnet is increased from its previous value, the coil will cut the lines of flux at a faster rate, so more induced emf would be produced.

Applications of Faraday's Law

Faraday law is one of the most basic and important laws of electromagnetism. This law finds its application in most of the electrical machines, industries, and the medical field, etc.

- Power transformers function based on Faraday's law

- The basic working principle of the electrical generator is Faraday's law of mutual induction.
- The Induction cooker is the fastest way of cooking. It also works on the principle of mutual induction. When current flows through the coil of copper wire placed below a cooking container, it produces a changing magnetic field. This alternating or changing magnetic field induces an emf and hence the current in the conductive container, and we know that the flow of current always produces heat in it.
- Electromagnetic Flow Meter is used to measure the velocity of certain fluids. When a magnetic field is applied to an electrically insulated pipe in which conducting fluids are flowing, then according to Faraday's law, an electromotive force is induced in it. This induced emf is proportional to the velocity of fluid flowing.
- Form bases of Electromagnetic theory, Faraday's idea of lines of force is used in well known Maxwell's equations. According to Faraday's law, change in magnetic field gives rise to change in electric field and the converse of this is used in Maxwell's equations.
- It is also used in musical instruments like an electric guitar, electric violin, etc.

4.2.2 Inductance of a Coil

The inductance of a coil refers to the electrical property the inductive coil has to oppose any change in the current flowing through it. It therefore follows that inductance is only present in an electric circuit when the current is changing.

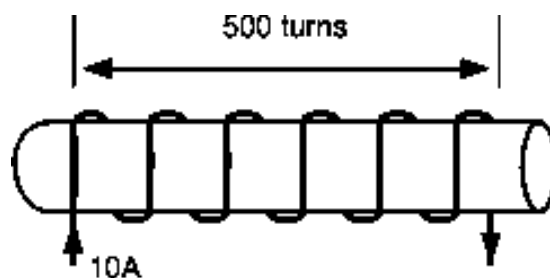

Inductors generate a self-induced emf within themselves as a result of their changing magnetic field. In an electrical circuit, when the emf is

induced in the same circuit in which the current is changing this effect is called Self-induction, (L) but it is sometimes commonly called back-emf as its polarity is in the opposite direction to the applied voltage.

When the emf is induced into an adjacent component situated within the same magnetic field, the emf is said to be induced by Mutual-induction, (M) and mutual induction is the basic operating principal of transformers, motors, relays etc. Self inductance is a special case of mutual inductance, and because it is produced within a single isolated circuit, we generally call self-inductance simply, Inductance.

The basic unit of measurement for inductance is called the Henry, (H) after Joseph Henry, but it also has the units of Weber per Ampere (1 H = 1 Wb/A).

Lenz's Law tells us that an induced emf generates a current in a direction which opposes the change in flux which caused the emf in the first place, the principal of action and reaction. Then we can accurately define Inductance as being: "a coil will have an inductance value of one Henry when an emf of one volt is induced in the coil were the current flowing through the said coil changes at a rate of one ampere/second". In other words, a coil has an inductance, (L) of one Henry, (1H) when the current flowing through the coil changes at a rate of one ampere/second, (A/s). This change induces a voltage of one volt, (V_L) in it. Thus, the mathematical representation of the rate of change of current through a wound coil per unit time is given as:

$$\frac{di}{dt} \quad (\text{A/s})$$

The voltage induced in a coil, (V_L) with an inductance of L Henries as a result of this change in current is expressed as:

$$V_L = -L \frac{di}{dt} \quad (\text{V})$$

Note that the negative sign indicates that voltage induced opposes the change in current through the coil per unit time (di/dt).

From the above equation, the inductance of a coil can therefore be presented as:

Inductance of a Coil

$$L = \frac{V_L}{(di/dt)} = \frac{1\text{volt}}{1\text{A/s}} = 1\text{Henry}$$

Where: L is the inductance in Henries, V_L is the voltage across the coil and di/dt is the rate of change of current in Amperes per second, A/s.

A) Self Inductance

The property of a circuit, by which an e.m.f. is induced in the circuit whenever the current flowing it changes, is termed as Self-Inductance. Consider a coil of N turns carrying a current of $1A$. The flux linking with the coil be Φ Weber.

The lines of flux linking the coil change with change in current. This will induce an e.m.f. according to Faraday's Law. The e.m.f. induced is called self-induced e.m.f.

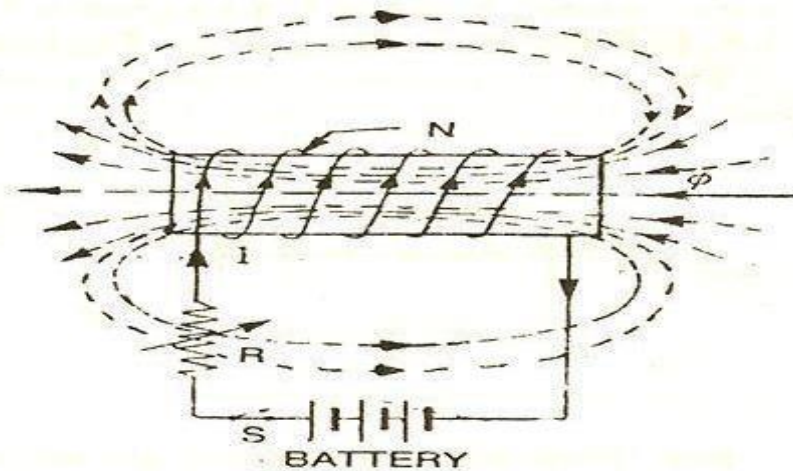

Inductors are made from individual loops of wire combined to produce a coil and if the number of loops within the coil are increased, then for the same amount of current flowing through the coil, the magnetic flux will also increase.

So, by increasing the number of loops or turns within a coil, increases the coils inductance. Then the relationship between self-inductance, (L) and the number of turns, (N) and for a simple single layered coil can be given as:

Coefficient of Self Inductance of a Coil

$$L = N \frac{\Phi}{I}$$

Where:

L is in Henries

N is the Number of Turns

Φ is the Magnetic Flux

I is in Amperes

This expression can also be defined as the magnetic flux linkage, ($N\Phi$) divided by the current, as effectively the same value of current flows through each turn of the coil. Note that this equation only applies to linear magnetic materials.

Example 7

A hollow air cored inductor coil consists of 500 turns of copper wire which produces a magnetic flux of 10mWb when passing a DC current of 10 amps. Calculate the self-inductance of the coil in milli-Henries.

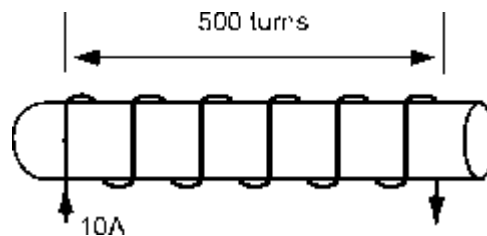

Solution

$$L = N \frac{\Phi}{I} = 500 \frac{0.01}{10} = 500\text{mH}$$

Example 8

Calculate the value of the self-induced emf produced in the same coil after a time period of 10 milli-seconds (10ms).

Solution

$$\text{emf} = L \frac{di}{dt} = 0.5 \frac{10}{0.01} = 500\text{V}$$

Coefficient of self-inductance for an air cored coil (solenoid)

The self-inductance of a coil or to be more precise, the coefficient of self-inductance also depends upon the characteristics of its construction. For a coil, the magnetic flux that is produced in its inner core is equal to:

$$\Phi = B.A$$

Where: Φ is the magnetic flux, B is the flux density, and A is the area.

If the inner core of a long solenoid coil with N number of turns per meter

length is hollow, “air cored”, then the magnetic induction within its core will be given as:

$$B = \mu_o H = \mu_o \frac{N.I}{\ell}$$

Then by substituting these expressions in the first equation above for Inductance will give us:

$$L = N \frac{\Phi}{I} = N \frac{B.A}{I} = N \frac{\mu_o . N . I . A}{\ell . I}$$

By cancelling out and grouping together like terms, then the final equation for the coefficient of self-inductance for an air cored coil (solenoid) is given as:

$$L = \mu_o \frac{N^2 . A}{\ell}$$

Where:

L is in Henries

μ_o is the Permeability of Free Space ($4.\pi.10^{-7}$)

N is the Number of turns

A is the Inner Core Area (πr^2) in m^2

ℓ is the length of the Coil in meters

As the inductance of a coil is due to the magnetic flux around it, the stronger the magnetic flux for a given value of current the greater will be the inductance. So, a coil of many turns will have a higher inductance value than one of only a few turns and therefore, the equation above will give inductance L as being proportional to the number of turns squared N^2 .

Example 9 A coil is wound with 500 turns. A current of 5 amperes flowing through the coil produces flux Φ of 80μ weber. Calculate its inductance.

Solution:

$$L = N \frac{\Phi}{I}$$

$$L = 500 \times 80 \times 10^{-6} / 5 \text{ Henry}$$

$$L = 0.0008 \text{ Henry}$$

Example 10 If the current through a coil having an inductance of 0.5H is reduced from 5A to 1A in 0.05 second, calculate the mean value of the e.m.f. induced in the coil.

Solution: Average rate of change of current
 $= (1-5)/0.05 = -80\text{A/sec.}$

Average induced e.m.f. in the coil

$$V_L = -L \frac{di}{dt} \quad (\text{V})$$

$$V_L = -0.5(-80) = 40\text{V}$$

B) Mutual Inductance

Mutual Inductance is the interaction of one coil magnetic field on another coil as it induces a voltage in the adjacent coil.

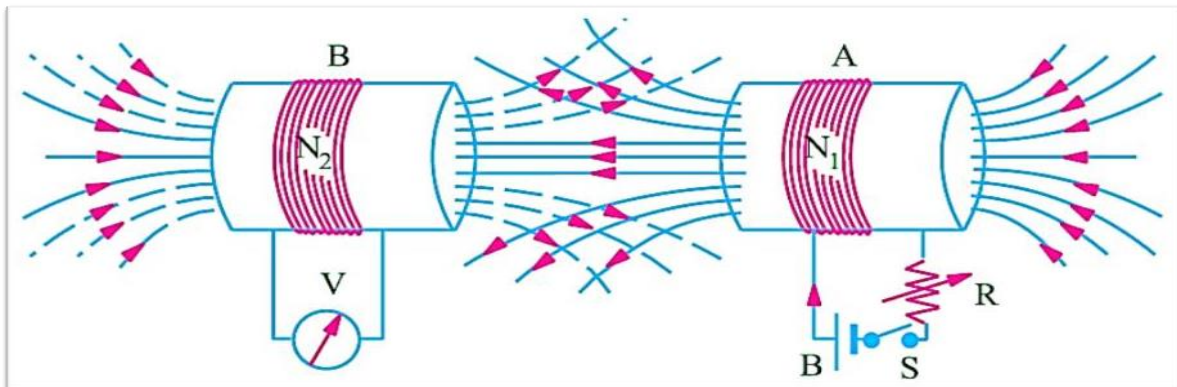

When the emf is induced into an adjacent coil situated within the same magnetic field, the emf is said to be induced magnetically, inductively or by Mutual induction, symbol (M). Then when two or more coils are magnetically linked together by a common magnetic flux, they are said to have the property of Mutual Inductance.

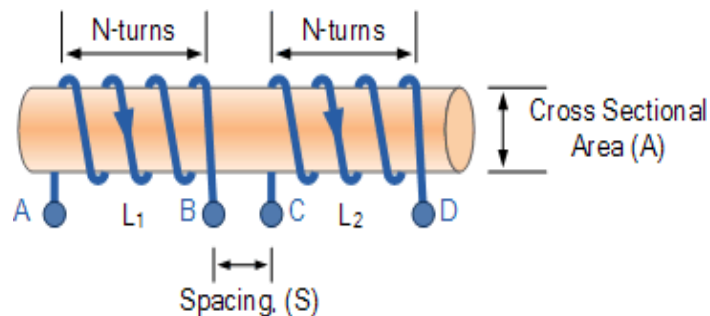

Mutual Inductance is the basic operating principal of the transformer,

motors, generators and any other electrical component that interacts with another magnetic field.

The amount of mutual inductance that links one coil to another depends very much on the relative positioning of the two coils. If one coil is positioned next to the other coil so that their physical distance apart is small, then nearly all of the magnetic flux generated by the first coil will interact with the coil turns of the second coil inducing a relatively large emf and therefore producing a large mutual inductance value.

Likewise, if the two coils are farther apart from each other or at different angles, the amount of induced magnetic flux from the first coil into the second will be weaker producing a much smaller induced emf and therefore a much smaller mutual inductance value. So the effect of mutual inductance is very much dependent upon the relative positions or spacing, (S) of the two coils and this is demonstrated below.

Mutual Inductance between Coils

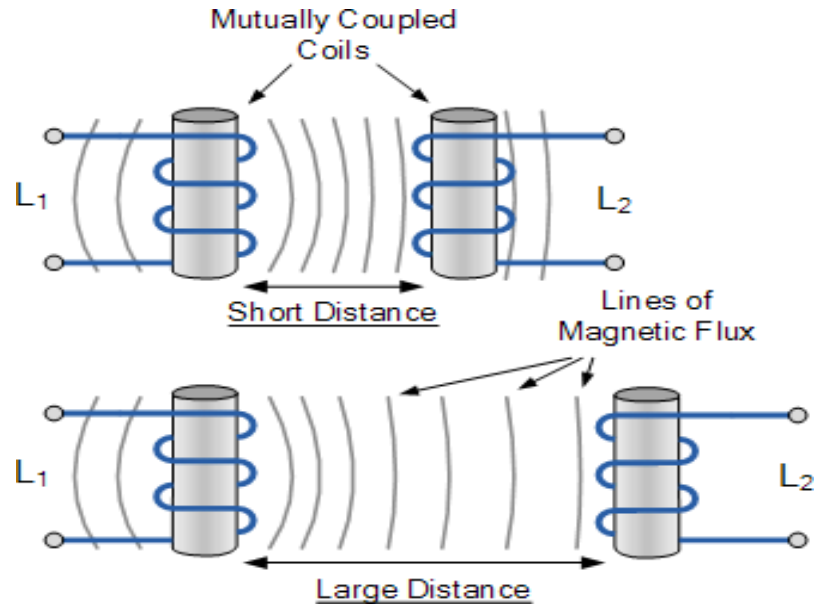

If the two coils are tightly wound one on top of the other over a common soft iron core unity coupling is said to exist between them as any losses due to the leakage of flux will be extremely small. Then assuming a perfect flux linkage between the two coils the mutual inductance that exists between them can be given as.

$$M = \frac{\mu_0 \mu_r N_1 N_2 A}{\ell}$$

Where:

μ_0 is the permeability of free space ($4\pi \cdot 10^{-7}$)

μ_r is the relative permeability of the soft iron core

N is in the number of coils turns

A is in the cross-sectional area in m^2

ℓ is the coils length in meters

Mutual Induction

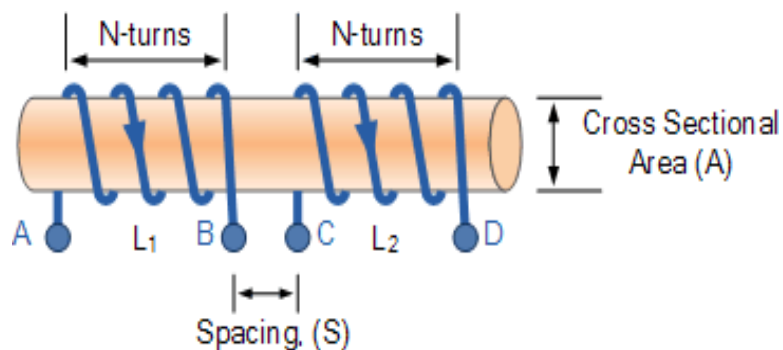

Here the current flowing in coil one, L_1 sets up a magnetic field around itself with some of these magnetic field lines passing through coil two, L_2 giving us mutual inductance. Coil one has a current of I_1 and N_1 turns while, coil two has N_2 turns. Therefore, the mutual inductance, M_{12} of coil two that exists with respect to coil one depends on their position with respect to each other and is given as:

$$M_{12} = \frac{N_2 \Phi_{12}}{I_1}$$

Likewise, the flux linking coil one, L_1 when a current flows around coil two, L_2 is exactly the same as the flux linking coil two when the same current flows around coil one above, then the mutual inductance of coil one with respect of coil two is defined as M_{21} . Because of this, we can write the mutual inductance between the two coils as: $M_{12} = M_{21} = M$. The self inductance of each individual coil is given as:

$$L_1 = \frac{\mu_0 \mu_r N_1^2 A}{\ell} \quad \text{and} \quad L_2 = \frac{\mu_0 \mu_r N_2^2 A}{\ell}$$

By cross-multiplying the two equations above, the mutual inductance, M that exists between the two coils can be expressed in terms of the self inductance of each coil.

$$M^2 = L_1 L_2$$

giving us a final and more common expression for the mutual inductance between the two coils of:

Mutual Inductance Between Coils

$$M = \sqrt{L_1 L_2} \quad \text{H}$$

However, the above equation assumes zero flux leakage and 100% magnetic coupling between the two coils, L_1 and L_2 . In reality there will always be some loss due to leakage and position, so the magnetic coupling between the two coils can never reach or exceed 100%, but can become very close to this value in some special inductive coils.

If some of the total magnetic flux links with the two coils, this amount of

flux linkage can be defined as a fraction of the total possible flux linkage between the coils. This fractional value is called the coefficient of coupling and is given the letter k.

Coupling Coefficient

Generally, the amount of inductive coupling that exists between the two coils is expressed as a fractional number between 0 and 1 instead of a percentage (%) value, where 0 indicates zero or no inductive coupling, and 1 indicating full or maximum inductive coupling.

In other words, if $k = 1$ the two coils are perfectly coupled, if $k > 0.5$ the two coils are said to be tightly coupled and if $k < 0.5$ the two coils are said to be loosely coupled. Then the equation above which assumes a perfect coupling can be modified to take into account this coefficient of coupling, k and is given as:

Coupling Factor between Coils

$$k = \frac{M}{\sqrt{L_1 L_2}} \quad \text{or} \quad M = k\sqrt{L_1 L_2}$$

When the coefficient of coupling, k is equal to 1, (unity) such that all the lines of flux of one coil cuts all of the turns of the second coil, that is the two coils are tightly coupled together, the resulting mutual inductance will be equal to the geometric mean of the two individual inductances of the coils.

Also, when the inductances of the two coils are the same and equal, L_1 is equal to L_2 , the mutual inductance that exists between the two coils will equal the value of one single coil as the square root of two equal values is the same as one single value as shown.

$$M = \sqrt{L_1 L_2} = L$$

More Detail

4.2.3 Statically and Dynamically Induced EMF

Induced EMF

When a magnetic flux linking a conductor or coil changes, an electromotive force (EMF) is induced in the conductor or coil, is known as *induced EMF*. Depending upon the way of bringing the change in magnetic flux, the induced EMF is of **two types** –

- Statically Induced EMF
- Dynamically Induced EMF

Statically Induced EMF

When the conductor is stationary and the magnetic field is changing, the induced EMF in such a way is known as *statically induced EMF* (as in a transformer). It is so called because the EMF is induced in a conductor which is stationary. The statically induced EMF can also be classified into **two categories** –

Statically Induced EMF

- Mutually Induced EMF
- Self-Induced EMF

When an EMF is induced in the coil due to the change of its own magnetic flux linked with it is known as *self-induced EMF*.

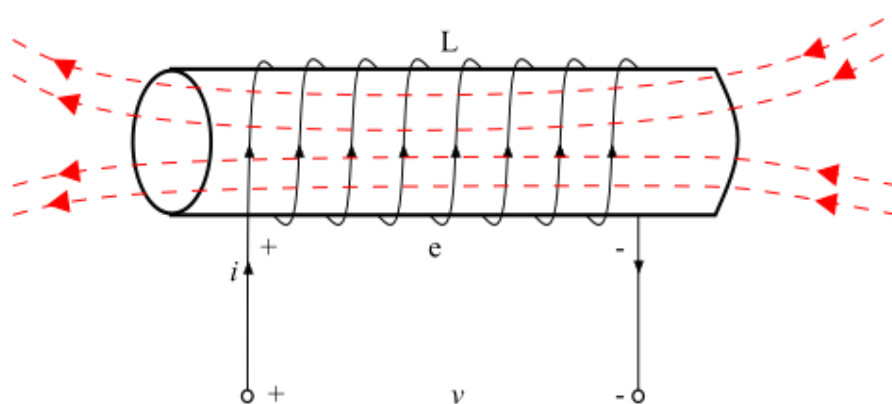

Explanation – When a current flows in a coil, a magnetic field produced by this current through the coil. If the current in the coil changes, then the magnetic field linking the coil also changes. Therefore, according to Faraday's law of electromagnetic induction, an EMF being induced in the coil. The induced EMF in such a way is known as *self-induced EMF*.

Mathematically, self-induced EMF is given by,

$$e = L \frac{di}{dt} \dots (1)$$

Where, L is the self-inductance of the coil.

Mutually Induced EMF

When an EMF is induced in a coil due to changing magnetic flux of neighboring coil is known as *mutually induced EMF*.

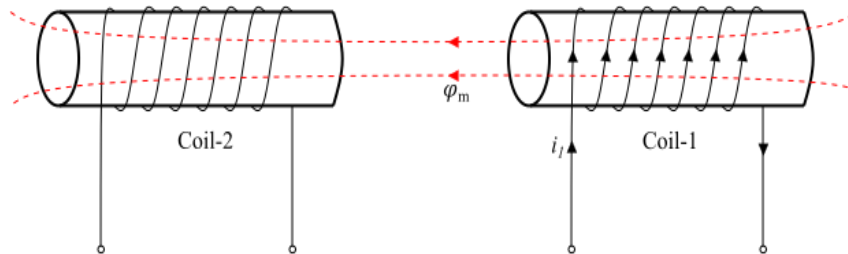

Explanation – Consider two coils coil-1 and coil-2 placed adjacent to each other (see the figure). A fraction of the magnetic flux produced by coil-1 links with the coil-2. This magnetic flux which is common to both the coils 1 and 2 is known as *mutual flux* (φ_m). Now, if the current in coil-1 changes, the mutual flux also changes and thus EMF being induced in both the coils. The EMF induced in coil-2 is known as *mutually induced EMF*, since it is induced due changing in flux which is produced by coil-1. Mathematically, the mutually induced EMF is given by,

$$E_{mf} = M di_1 / dt \dots (2)$$

Where, M is the mutual inductance between the coils.

Dynamically Induced EMF

When the conductor is moved in a stationary magnetic field so that the magnetic flux linking with it changes in magnitude, as the conductor is subjected to a changing magnetic, therefore an EMF will be induced in it. The EMF induced in this way is known as *dynamically induced EMF* (as in a DC or AC generator). It is so called because EMF is induced in a conductor which is moving (dynamic).

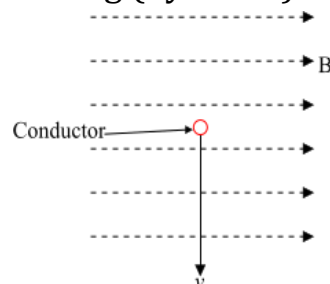

Explanation – Consider a conductor of length l meters moving with a velocity of v m/s at right angles to a uniform stationary magnetic field of

flux density $B \text{ Wb/m}^2$. Let the conductor moves through a small distance dx in time dt seconds. Then,
 Area swept by conductor, $a = l \times dx \text{ m}^2$
 \therefore Magnetic flux cut by conductor, $d\psi = \text{Magnetic Flux Density} \times \text{Area Swept}$

$$\Rightarrow d\psi = B l dx \text{ Wb}$$

Now, according to Faraday's law of electromagnetic induction, the induced EMF will be,

$$E = N d\psi/dt = B l dx/dt \quad (\because N=1)$$

$$\because dx/dt = \text{Velocity } V$$

$$\therefore e = B l v \text{ Volts...} \quad (3)$$

Equation (3) gives the dynamically induced EMF when the conductor moves at right angle to the magnetic field.

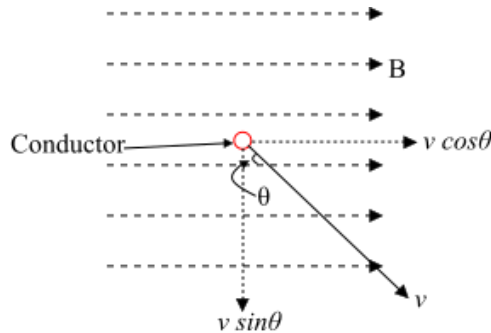

If the conductor moves at an angle θ to the magnetic field, then the EMF induced due to only the perpendicular component of the velocity to the magnetic field.

$$e = B l v \sin \theta \dots\dots (4)$$

Example 11

Two inductors whose self-inductances are given as 75mH and 55mH respectively, are positioned next to each other on a common magnetic core so that 75% of the lines of flux from the first coil are cutting the second coil. Calculate the total mutual inductance that exists between the two coils.

Solution:

$$M = k\sqrt{L_1 L_2}$$

$$M = 0.75\sqrt{75\text{mH} \times 55\text{mH}} = 48.2\text{mH}$$

Example 12

When two coils having inductances of 5H and 4H respectively were wound uniformly onto a non-magnetic core, it was found that their mutual inductance was 1.5H. Calculate the coupling coefficient that exists between.

Solution:

$$k = \frac{M}{\sqrt{L_1 L_2}} = \frac{1.5}{\sqrt{5 \times 4}} = 0.335 = 33.5\%$$

Example 13. Two coils have a mutual inductance of 0.6 H. if the current in one coil varied from 4 to 1 A in 0.6 s, calculate:

(a) the emf induced in the second coil

(b) the change of flux linked with the second coil, assuming that it is wound with 200 turns.

Solution:

(a) Average rate of increase of current in one coil= $(1-4)/0.6 = -5\text{A/s}$

So the average emf induced in other coil

$$= -0.6 \text{ Henry} \times (-5) \text{ A/S}$$

$$= 3\text{V Ans}$$

(b) If the change of flux linked with the second coil is ϕ , then emf induced in that coil

$$= \phi \times \text{number of turns/time in}$$

seconds

$$3 = \phi \times 200 / 0.6$$

So

$$\phi = 3 \times 0.6 / 200$$

$$= 0.009 \text{ Wb} = 9\text{mWb Ans.}$$

Example 14 A wooden ring has a mean diameter of 150π mm and a cross-sectional area of 250 mm^2 . It is wound with 1500 turns of insulated wire. A second coil of 900 turns is then wound on the top of the first. Assuming that all the flux produced by the first coil links with the second, calculate the mutual inductance.

Solution:

Number of turns on coil A $N_1=1500$

Number of turns on coil B $N_2=900$

Relative permeability of wood $\mu_r=1.0$
($\mu_0=4\pi\times 10^{-7}$)

Area of cross section of wooden ring

$$A = 250 \text{ mm}^2 = 250 \times 10^{-4} \text{ m}^2$$

Length of wooden ring $l=150 \pi \text{ mm} = 0.15\pi \text{ m}$

Mutual Inductance =

$$M = \frac{\mu_0 \mu_r N_1 N_2 A}{l}$$

$$M = 1500 \times 900 \times 4\pi \times 10^{-7} \times 1 \times 2.5 \times 10^{-4} / 0.15\pi$$

$$M = 0.9 \text{ mH Ans.}$$

4.3.1 The energy stored in an inductor

The energy stored in an inductance coil having inductance L and R is the resistance of the coil.

Suppose a current I is applied to an inductor or inductance coil of inductance L

such that current through the inductor grows from zero value to a maximum value I . Let current through the inductor at any instant of time t be i .

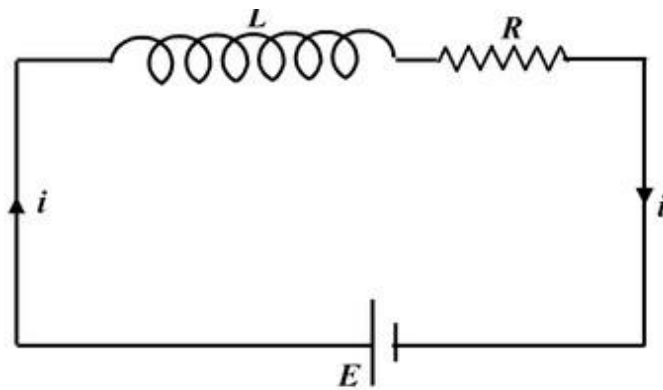

Fig. (4.24) A series LR circuit

Let i be the instantaneous current in the circuit then applying Kirchhoff's voltage law, we get

$$E = iR + L \frac{di}{dt}$$

The power supplied by the battery is given by

$$P = Ei = i^2R + Li \, di/dt$$

where i^2R is the power dissipated in the resistor and the last term represents the rate at which energy is being supplied to the inductor. An emf induced in the inductor which opposes the flow of current and is given by the formula,

$$E = -L \, di/dt$$

where L is the inductance and di/dt is the rate of change of current.

In order to pass current through the circuit, work must be done by the voltage source against this emf. The formula for rate of work done is given by,

$$dW/dt = -Ei$$

$$dW = -E \, i \, dt$$

Putting the value of E , we get,

$$dW = -(-L \, di/dt) \, i \, dt$$

$$dW = iL \, di$$

Now, integrating on L.H.S from 0 to W and on R.H.S from 0 to I , we get

$$\int_0^W dW = \int_0^I iLdi$$

$$\Rightarrow W = L \int_0^I idi$$

$$\Rightarrow W = L \left[\frac{i^2}{2} \right]_0^I$$

$$\Rightarrow W = L \left[\frac{I^2}{2} \right]$$

$$\therefore W = \frac{1}{2} LI^2$$

The energy stored in the inductor can be calculated as

When current in the coil changes from zero to I amperes, emf induced in it is equal to

L times rate of change of current.

Time taken by the current from zero to I ampere is t seconds.

Then $E = -L(0-I)/t = IL/t$ volts

Average current $= (0+I)/2 = I/2$

Energy stored $= \{\text{current} \times \text{e.m.f.} \times \text{time}\} = I/2 \times (IL/t) \times t = 0.5 LI^2$

Note: Remember, one function of an inductor is to store electrical energy. There is one more component called capacitor. A capacitor stores energy in the electric field whereas an inductor stores energy in the magnetic field, students sometimes get confused between these two components. The battery that establishes the current in an inductor has to do work against the opposing induced emf. The energy supplied by the battery is stored in the inductor.

Example 15 The field winding of electromagnet of d.c. motor has 1500 turns and 110ohm resistance. Its exciting voltage is 220V, which produce a flux of 6mWb. Find out the energy stored in the field of motor.

Solution.

Energy stored in the magnetic circuit = $0.5 LI^2$

$$L = N \frac{\Phi}{I}$$

Where

Current $I = 220/110 = 2 \text{ A}$

$L = 0.5(1500 \times 6 \times 10^{-3}) = 3 \text{ Henry}$

Energy stored $W = 0.5 LI^2$

$W = 0.5 \times 3 \times 4 = 6 \text{ Joules.}$

4.3.2 Series and Parallel Combination of Inductors:

A) Inductors in Series

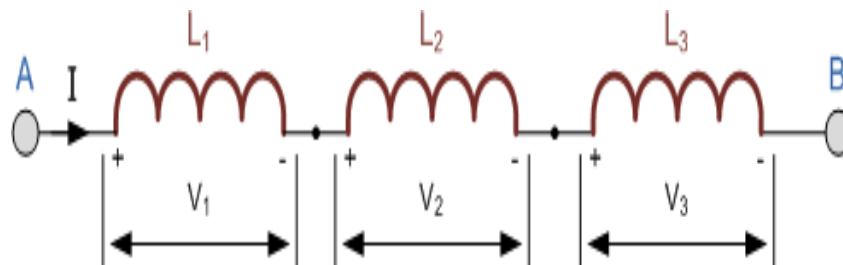

Inductors can be connected together in a series connection when they are daisy chained together sharing a common electrical current

These interconnections of inductors produce more complex networks whose overall inductance is a combination of the individual inductors.

However, there are certain rules for connecting inductors in series or parallel and these are based on the fact that no mutual inductance or magnetic coupling exists between the individual inductors.

Inductors are said to be connected in “Series” when they are daisy chained together in a straight line, end to end. In the Resistors in Series we saw that the different values of the resistances connected together in series just “add” together and this is also true of inductance. Inductors in series are simply “added together” because the number of coil turns is effectively increased, with the total circuit inductance L_T being equal to the sum of all the individual inductances added together.

Inductor in Series Circuit

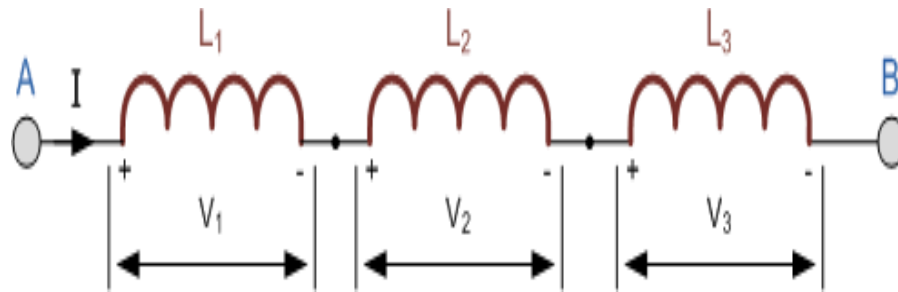

The current, (I) that flows through the first inductor, \$L_1\$ has no other way to go but pass through the second inductor and the third and so on. Then, series inductors have a Common Current flowing through them, for example:

$$I_{L1} = I_{L2} = I_{L3} = I_{AB} \dots \text{etc.}$$

In the example above, the inductors \$L_1\$, \$L_2\$ and \$L_3\$ are all connected together in series between points A and B. The sum of the individual voltage drops across each inductor can be found using Kirchhoff's Voltage Law (KVL) where, \$V_T = V_1 + V_2 + V_3\$ and we know from the previous tutorials on inductance that the self-induced emf across an inductor is given as: \$V = L \, di/dt\$.

So, by taking the values of the individual voltage drops across each inductor in our example above, the total inductance for the series combination is given as:

$$L_T \frac{di}{dt} = L_1 \frac{di}{dt} + L_2 \frac{di}{dt} + L_3 \frac{di}{dt}$$

By dividing through the above equation by \$di/dt\$ we can reduce it to give a final expression for calculating the total inductance of a circuit when connecting inductors together in series and this is given as:

Inductors in Series Equation

$$L_{\text{total}} = L_1 + L_2 + L_3 + \dots + L_n$$

Then the total inductance of the series chain can be found by simply adding together the individual inductances of the inductors in series just like adding together resistors in series. However, the above equation only holds true when there is "NO" mutual inductance or magnetic coupling between two or more of the inductors, (they are magnetically isolated from each other).

One important point to remember about inductors in series circuits, the total inductance (L_T) of any two or more inductors connected together in series will always be GREATER than the value of the largest inductor in the series chain.

Example 16

Three inductors of 10mH, 40mH and 50mH are connected together in a series combination with no mutual inductance between them. Calculate the total inductance of the series combination.

$$L_T = L_1 + L_2 + L_3 = 10\text{mH} + 40\text{mH} + 50\text{mH} = 100\text{mH}$$

Mutually Connected Inductors in Series

When inductors are connected together in series so that the magnetic field of one links with the other, the effect of mutual inductance either increases or decreases the total inductance depending upon the amount of magnetic coupling. The effect of this mutual inductance depends upon the distance apart of the coils and their orientation to each other.

Mutually connected series inductors can be classed as either “Aiding” or “Opposing” the total inductance. If the magnetic flux produced by the current flows through the coils in the same direction, then the coils are said to be Cumulatively Coupled. If the current flows through the coils in opposite directions, then the coils are said to be Differentially Coupled as shown below.

Cumulatively Coupled Series Inductors

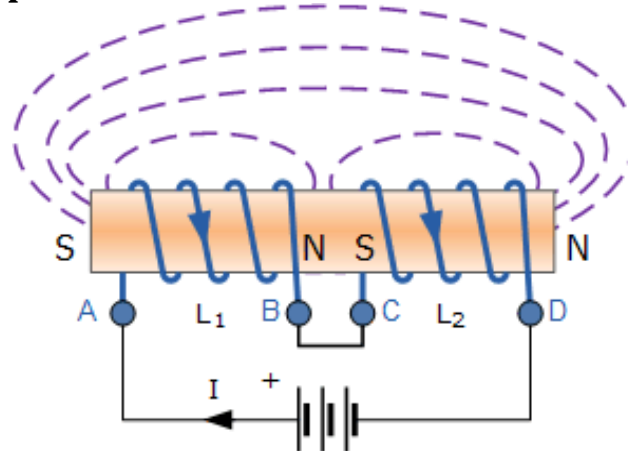

While the current flowing between points A and D through the two cumulatively coupled coils is in the same direction, the equation above for the voltage drops across each of the coils needs to be modified to take

into account the interaction between the two coils due to the effect of mutual inductance. The self inductance of each individual coil, L_1 and L_2 respectively will be the same as before but with the addition of M denoting the mutual inductance.

Then the total emf induced into the cumulatively coupled coils is given as:

$$L_T \frac{di}{dt} = L_1 \frac{di}{dt} + L_2 \frac{di}{dt} + 2 \left(M \frac{di}{dt} \right)$$

Where: $2M$ represents the influence of coil L_1 on L_2 and likewise coil L_2 on L_1 .

By dividing through the above equation by di/dt we can reduce it to give a final expression for calculating the total inductance of a circuit when the inductors are cumulatively connected and this is given as:

$$L_{\text{total}} = L_1 + L_2 + 2M$$

If one of the coils is reversed so that the same current flows through each coil but in opposite directions, the mutual inductance, M that exists between the two coils will have a cancelling effect on each coil as shown below.

Differentially Coupled Series Inductors

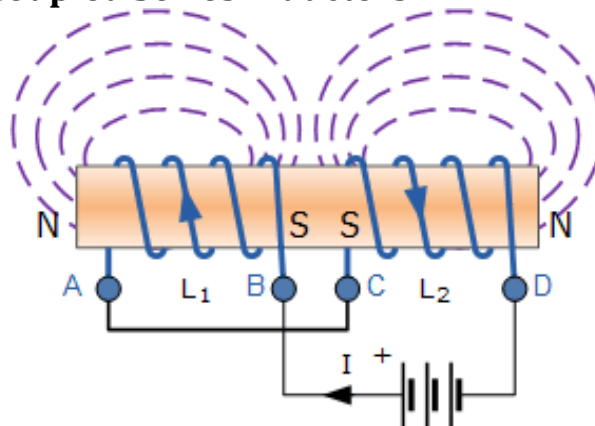

The emf that is induced into coil 1 by the effect of the mutual inductance of coil two is in opposition to the self-induced emf in coil one as now the same current passes through each coil in opposite directions. To take account of this cancelling effect a minus sign is used with M when the magnetic field of the two coils are differentially connected giving us the final equation for calculating the total inductance of a circuit when the inductors are differentially connected as:

$$L_{\text{total}} = L_1 + L_2 - 2M$$

Then the final equation for inductively coupled inductors in series is given as:

$$L_T = L_1 + L_2 \pm 2M$$

Coefficient of Coupling

The fractional part of magnetic flux produced by the current of one coil which links with the other coil is called co-efficient of coupling. It is denoted by K.

$$K = M / (\sqrt{L_1 L_2})$$

Where K= co-efficient of coupling between two coils

M= Mutual Inductance between two coils

L₁ = Self Inductance of one coil

L₂= Self Inductance of another coil

Example 17

Two inductors of 10mH respectively are connected together in a series combination so that their magnetic fields aid each other giving cumulative coupling. Their mutual inductance is given as 5mH. Calculate the total inductance of the series combination. Also compute the coefficient of coupling.

$$L_T = L_1 + L_2 + 2M$$

$$L_T = 10\text{mH} + 10\text{mH} + 2(5\text{mH})$$

$$L_T = 30\text{mH}$$

$$K = M / (\sqrt{L_1 L_2})$$

$$= 5 / (\sqrt{10 \times 10})$$

$$K = 0.5 \text{ Ans}$$

Example 18

Two coils connected in series have a self-inductance of 20mH and 60mH respectively. The total inductance of the combination was found to be 100mH. Determine the amount of mutual inductance that exists between the two coils assuming that they are aiding each other.

$$L_T = L_1 + L_2 \pm 2M$$

$$100 = 20 + 60 + 2M$$

$$2M = 100 - 20 - 60$$

$$\therefore M = \frac{20}{2} = 10\text{mH}$$

B) Inductors in Parallel

Inductors are said to be connected together in Parallel when both of their terminals are respectively connected to each terminal of another inductor or inductors

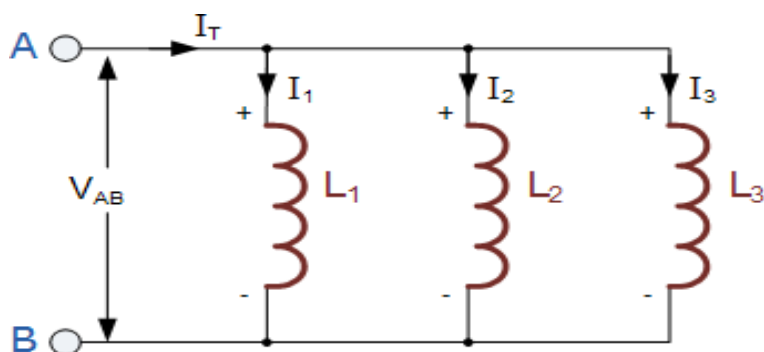

The voltage drops across all of the inductors in parallel will be the same. Then, Inductors in Parallel have a Common Voltage across them and in our example below the voltage across the inductors is given as:

$$V_{L1} = V_{L2} = V_{L3} = V_{AB} \dots\text{etc}$$

In the following circuit the inductors L_1 , L_2 and L_3 are all connected together in parallel between the two points A and B.

Inductors in Parallel Circuit

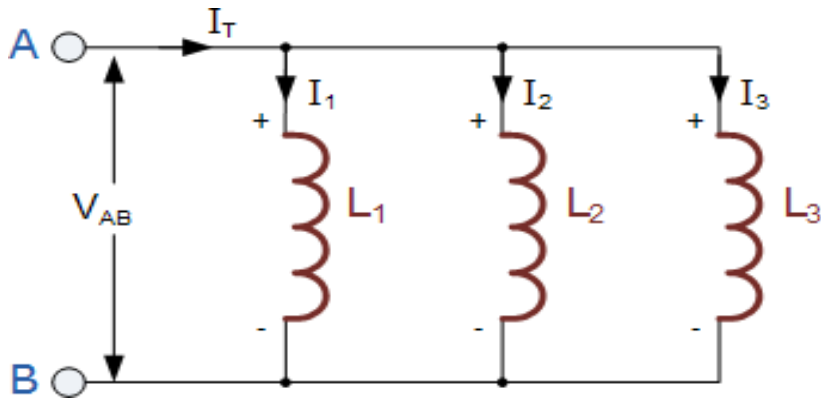

In series inductors, the total inductance, L_T of the circuit was equal to the sum of all the individual inductors added together. For parallel connected inductors, the equivalent circuit inductance L_T is calculated differently.

The sum of the individual currents flowing through each inductor can be found using Kirchhoff's Current Law (KCL) where, $I_T = I_1 + I_2 + I_3$ and we know from the previous tutorials on inductance that the self-induced emf across an inductor is given as: $V = L \frac{di}{dt}$

Then by taking the values of the individual currents flowing through each inductor in our circuit above, and substituting the current i for $i_1 + i_2 + i_3$ the voltage across the parallel combination is given as:

$$V_{AB} = L_T \frac{d}{dt}(i_1 + i_2 + i_3) = L_T \left(\frac{di_1}{dt} + \frac{di_2}{dt} + \frac{di_3}{dt} \right)$$

By substituting di/dt in the above equation with v/L gives:

$$V_{AB} = L_T \left(\frac{v}{L_1} + \frac{v}{L_2} + \frac{v}{L_3} \right)$$

We can reduce it to give a final expression for calculating the total inductance of a parallel circuit, and this is given as:

Parallel Inductor Equation

$$\frac{1}{L_T} = \frac{1}{L_1} + \frac{1}{L_2} + \frac{1}{L_3} \dots + \frac{1}{L_N}$$

Here, like the calculations for parallel resistors, the reciprocal ($1/L_n$ value of the individual inductances are all added together instead of the

inductances themselves. But again, as with series connected inductances, the above equation only holds true when there is “NO” mutual inductance or magnetic coupling between two or more of the inductors, (they are magnetically isolated from each other). Where there is coupling between coils, the total inductance is also affected by the amount of coupling. This method of calculation can be used for calculating any number of individual inductances connected together within a single parallel network. If, however, there are only two individual parallel connected inductances then a much simpler and quicker formula can be used to find the total inductance value, and this is:

$$L_T = \frac{L_1 \times L_2}{L_1 + L_2}$$

One important point to remember about parallel inductive circuits, the total inductance (L_T) of any two or more inductors connected together in parallel will always be LESS than the value of the smallest inductance in the parallel branch.

Example 19

Three inductors of 60mH, 120mH and 75mH respectively, are connected together in a parallel combination with no mutual inductance between them. Calculate the total inductance of the parallel combination in millihenries.

$$\frac{1}{L_T} = \frac{1}{L_1} + \frac{1}{L_2} + \frac{1}{L_3}$$

$$\therefore L_T = \frac{1}{\frac{1}{L_1} + \frac{1}{L_2} + \frac{1}{L_3}} = \frac{1}{\frac{1}{60\text{mH}} + \frac{1}{120\text{mH}} + \frac{1}{75\text{mH}}}$$

$$L_T = \frac{1}{38.333} = 26\text{mH}$$

Mutually Coupled Parallel Inductors

When inductors are connected together in parallel so that the magnetic

field of one links with the other, the effect of mutual inductance either increases or decreases the total inductance depending upon the amount of magnetic coupling that exists between the coils. The effect of this mutual inductance depends upon the distance apart of the coils and their orientation to each other.

Mutually connected parallel inductors can be classed as either “aiding” or “opposing” the total inductance with parallel aiding connected coils increasing the total equivalent inductance and parallel opposing coils decreasing the total equivalent inductance compared to coils that have zero mutual inductance.

Mutual coupled parallel coils can be shown as either connected in an aiding or opposing configuration by the use of polarity dots or polarity markers as shown below.

Parallel Aiding Inductors

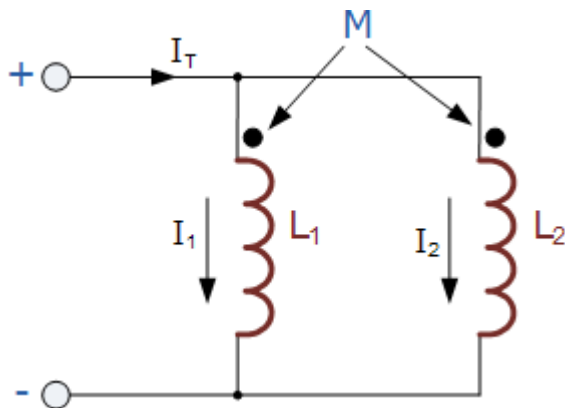

The voltage across the two parallel aiding inductors above must be equal since they are in parallel so the two currents, i_1 and i_2 must vary so that the voltage across them stays the same. Then the total inductance, L_T for two parallel aiding inductors is given as:

$$L_T = \frac{L_1 L_2 - M^2}{L_1 + L_2 - 2M}$$

Where: $2M$ represents the influence of coil L_1 on L_2 and likewise coil L_2 on L_1 .

If the two inductances are equal and the magnetic coupling is perfect such as in a toroidal circuit, then the equivalent inductance of the two

inductors in parallel is L as $L_T = L_1 = L_2 = M$. However, if the mutual inductance between them is zero, the equivalent inductance would be $L \div 2$ the same as for two self-induced inductors.

If one of the two coils was reversed with respect to the other, we would then have two parallel opposing inductors and the mutual inductance, M that exists between the two coils will have a cancelling effect on each coil instead of an aiding effect as shown below.

Parallel Opposing Inductors

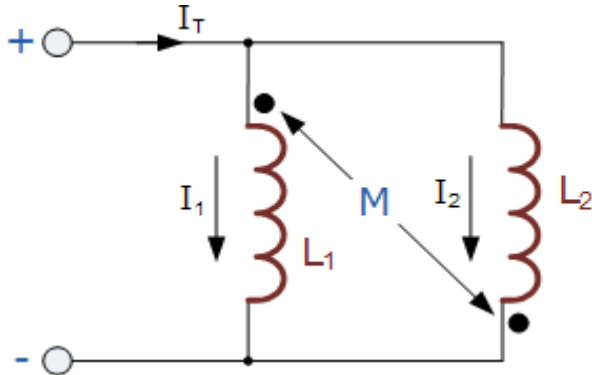

Then the total inductance, L_T for two parallel opposing inductors is given as:

$$L_T = \frac{L_1 L_2 - M^2}{L_1 + L_2 + 2M}$$

This time, if the two inductances are equal in value and the magnetic coupling is perfect between them, the equivalent inductance and also the self-induced emf across the inductors will be zero as the two inductors cancel each other out.

This is because as the two currents, i_1 and i_2 flow through each inductor in turn the total mutual flux generated between them is zero because the two fluxes produced by each inductor are both equal in magnitude but in opposite directions.

Then the two coils effectively become a short circuit to the flow of current in the circuit so the equivalent inductance, L_T becomes equal to $(L \pm M) \div 2$.

Example 20

Two inductors whose self-inductances are of 75mH and 55mH respectively are connected together in parallel aiding. Their mutual

inductance is given as 22.5mH. Calculate the total inductance.

$$L_T = \frac{L_1 \times L_2 - M^2}{L_1 + L_2 - 2M}$$

$$L_T = \frac{75\text{mH} \times 55\text{mH} - 22.5\text{mH}^2}{75\text{mH} + 55\text{mH} - 2 \times 22.5\text{mH}}$$

$$L_T = 42.6\text{mH}$$

Example 21

Calculate the equivalent inductance of the following inductive circuit.

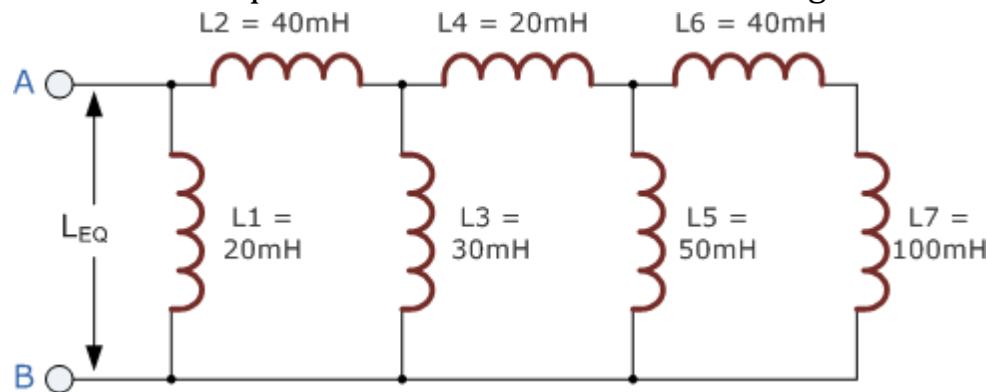

Calculate the first inductor branch L_A , (Inductor L_5 parallel with inductors L_6 and L_7)

$$L_A = \frac{L_5 \times (L_6 + L_7)}{L_5 + L_6 + L_7} = \frac{50\text{mH} \times (40\text{mH} + 100\text{mH})}{50\text{mH} + 40\text{mH} + 100\text{mH}} = 36.8\text{mH}$$

Calculate the second inductor branch L_B , (Inductor L_3 in parallel with inductors L_4 and L_A)

$$L_B = \frac{L_3 \times (L_4 + L_A)}{L_3 + L_4 + L_A} = \frac{30\text{mH} \times (20\text{mH} + 36.8\text{mH})}{30\text{mH} + 20\text{mH} + 36.8\text{mH}} = 19.6\text{mH}$$

Calculate the equivalent circuit inductance L_{EQ} , (Inductor L_1 in parallel with inductors L_2 and L_B)

$$L_{EQ} = \frac{L_1 \times (L_2 + L_B)}{L_1 + L_2 + L_B} = \frac{20\text{mH} \times (40\text{mH} + 19.6\text{mH})}{20\text{mH} + 40\text{mH} + 19.6\text{mH}} = 15\text{mH}$$

Example 22.

Consider a solenoid with 500 turns which are wound on an iron core whose relative permeability is 800. 40 cm is the length of the solenoid, while 3 cm is the radius. The change in current is from 0 to 3 A. Calculate the average emf induced for this change in the current for a time of 0.4 seconds.

Solution:

Given:

No. of turns, $N = 500$ turns

Relative permeability, $\mu_r = 800$

Length, $l = 40 \text{ cm} = 0.4 \text{ m}$

Radius, $r = 3 \text{ cm} = 0.03 \text{ m}$

Change in current, $di = 3 - 0 = 3 \text{ A}$

Change in time, $dt = 0.4 \text{ sec}$

Self-inductance is given as

$$L = \mu N^2 A l = \mu_0 \mu_r N^2 \pi r^2 / l$$

Substituting the values, we get

$$(4) (3.14) (10^{-7}) (800) (500^2) (3.14) (3 \times 10^{-2})^2 / 0.4$$

$$L = 1.77 \text{ H}$$

$$\text{Magnitude of induced emf: } V_L = L di/dt = 1.77 \times 3 / 0.4$$

$$V_L = 13.275 \text{ V}$$

Example 23.

There are two coils such that the current flowing through the first coil experiences a change in current flow from 2 A to 10 A in 0.4 sec. Calculate mutual inductance between the two coils when 60 mV emf is induced in the second coil. Determine the induced emf in the second coil if the current changes from 4 A to 16 A in 0.03 sec in the first coil.

Solution:

Given:

Case 1:

Change in current, $di = 10 - 2 = 8 \text{ A}$

Change in time, $dt = 0.4 \text{ sec}$

Magnitude of induced emf, $V_2 = 60 \times 10^{-3} \text{ V}$

Case 2:

Change in current, $di = 16 - 4 = 12 \text{ A}$

Change in time, $dt = 0.03 \text{ sec}$

Mutual inductance of the second coil with respect to the first coil is given as:

$$M_{21} = V_2 / (di/dt) = 60 \times 10^{-3} \times 0.4 / 8 = 3 \times 10^{-3} \text{ H}$$

Induced emf in the second coil due to change in the rate of current in the first coil is given as:

$$V_2 = M_{21} di/dt = 3 \times 10^{-3} \times 12 / 0.03 = 1.2 \text{ V}$$

Difference between Self and Mutual Inductance

Self inductance	Mutual inductance
In self-inductance, the change in the strength of current in the coil is opposed by the coil itself by inducing an e.m.f.	In mutual inductance out of the two coils one coil opposes change in the strength of the current flowing in the other coil.
The induced current opposes the growth of current in the coil when the main current in the coil increases.	The induced current developed in the neighboring coil opposes the growth of current in the coil when the main current in the coil increases.
The induced current opposes the decay of current in the coil when the main current in the coil decreases.	The induced current developed in the neighboring coil opposes the decay of the current in the coil when the main current in the coil decreases.

Q1. What is Inductance?

Inductance is the tendency of an electrical conductor to oppose a change in the electric current flowing through it. It is denoted by L.

One Henry:

One henry is defined as the amount of inductance required to produce an emf of 1 volt in a conductor when the current change in the conductor is at the rate of 1 Ampere per second.

Q2. What are the factors that affect inductance?

The following factors affect the inductance in a circuit:

- Number of Wire Turns in the Coil
- Coil Area
- Core Material
- Coil Length

Q3. How is the mutual inductance of a pair affected when the separation between the coils is increased?

When the separation between the coils is increased, the magnetic flux linked with the secondary coil will decrease. Therefore, the mutual inductance of the pair of coils decreases.

Q4. What is the application of mutual inductance?

Mutual inductance can be used in transformers, generators and electric motors.

Q5. How do energy store in an inductor?

Ans. Let assume we have an electrical circuit containing a power source and a solenoid for inductance L , we can write the magnetic field number, E , stored in the inductor as $E = 1/2 \times L \times I^2$, where I is the current flowing through the wire.

Q6. How much energy is stored in an inductor in a steady-state?

Ans. If the current flowing in the inductor does not change as in the DC circuit, then there will be no change in the stored energy, such as $P = Li (di / dt) = 0$.

Q7. What is the inductor formula?

Ans. We know that the voltage across an inductor is given by the equation. $V = L di / dt$.

We can write, $V_{AB} = L_{Total} \times dl / dt$. $V_{AB} = L_{Total} \times d (I_1 + I_2 + I_3) / dt$.

Q8. What is the energy stored in the capacitor?

Ans. Electrostatic potential energy gets stored in the capacitor. It is then related to the charge and voltage between the capacitor plates.

Q9. What is the unit of inductor?

Ans. The SI unit of inductance is Henry, abbreviated as 'H'. It is defined as the measure of electric current changes at one ampere per second, resulting in an electromotive force of one volt across the inductor.

What do we call the phenomenon of production of back emf in a coil due to the flow of varying current through it?

- A. Self-inductance
- B. Electromagnetic Induction
- C. Magnetic flux
- D. Magnetic moment

Answer: A. Self-inductance is that phenomenon in which change in electric current in a coil produces an induced emf in the coil itself.

Q10. Two coils A and B have $L = 2 \times 10^{-2}$ Henry. If the current in the primary is $i = 5 \sin 10\pi\theta$ then maximum value of emf induced in coil B is:

- A. π volt
- B. $\pi 2$ volt
- C. $\pi 3$ volt
- D. $\pi 4$ volt

Answer: A Given that, Current $i=5\sin(10\pi t)$, Mutual inductance

$$L=2\times 10^{-2} \text{ and } H=0.02\text{H}$$

Induced emf, $E = -M di/dt$

$$\therefore |E| = M \times 5 (10\pi) \cos(10\pi t)$$

$$= \pi \text{ volt}$$

Multiple Choice Questions:

1. Molecular theory of magnetism is given by:

- (a) Enwine (b) Weber
(c) Faraday (d) Fleming.

2. The value of permeability of free space is:

- (a) $4\pi \times 10^{-9}$ henry/meter (b) $4\pi \times 10^{-8}$ henry/meter
(c) $4\pi \times 10^{-7}$ henry/meter (d) $4\pi \times 10^{-6}$ henry/meter

3. A solenoid coil must have:

- (a) Length and breadth equal (b) Length greater than breadth
(c) Breadth greater than length (d) None of the above.

4. In the core of a solenoid

- (a) Copper is used (b) Soft iron is used
(c) Aluminum is used (d) None of the above.

5. The property of a material which opposes the creation of magnetic flux in it is known as:

- (a) Magnetomotive force (b) Reluctance
(c) Permeance (d) Reluctivity.

6. Reciprocal of reluctance is:

- (a) Susceptibility (b) Permeability

(c) Permeance (d) Reluctivity.

7. The force between two long parallel conductors is inversely proportional to:

- (a) Current in one conductor (b) Product of current in two conductors
(c) Distance between the conductors (d) Radius of conductors.

8. The direction magnetic lines of force is determined by:

- (a) Right hand rule (b) Right hand cork screw rule
(c) Both of the above rules (d) None of the above rules.

9. The direction of magnetic lines of force, when current is in to the plane of paper, is in:

- (a) Clockwise direction (b) Anti clockwise direction
(c) In a straight line (d) None of the above.

10. The direction magnetic lines of force, when current is out of the plane of paper is in:

- (a) Clockwise direction (b) Anti clockwise direction
(c) In a straight line (d) None of the above

29 Unit of magneto motive force is:

- (a) Weber
- (b) Tesla
- (c) Amp-turns (True)
- (d) Henry

30 Unit of flux density is:

- (a) Weber/m² (True)
- (b) Tesla
- (c) Joule
- (d) Weber/m

31 Energy stored in a magnetic field is measured in:

- (a) kWh
- (b) Coulombs
- (c) Joules (True)
- (d) Watts

32 EMF induced in a coil is directly proportional to:

- (a) rate of change of current
- (b) rate of change of flux
- (c) both a and b (True)
- (d) a or c

33 The emf induced in a coil depends on;

- (a) Number of turns
- (b) change of flux
- (c) time taken
- (d) all of the above (True)

34 Direction of induced emf is found by:

- (a) Fleming's Left-hand rule
- (b) Fleming's Right-hand rule (True)
- (c) Lenz's Law
- (d) Both b and c

35. Magnetic effect of current was discovered by:

- (a) Oersted (True)
- (b) Faraday
- (c) Bohr
- (d) Amper

ANSWES

-
- 01.(b) 02.(c) 03.(b) 4.(b) 5.(b)
 - 06.(c) 07.(c) 08.(c) 09.(a) 10.(b)